

March 2020

FAG and FA Series Cartridge Filters

SUMMARY

Introduction	1
Type FAG P.E.D. Categories and Characteristics	2
Type FA P.E.D. Categories and Characteristics	2
Labelling	3
Transport and Handling	3
Preservation and Storage	3
Atex Requirements	3
Operation	4
Installation	4
Startup and Shutdown	5
Maintenance	6
Spare parts	6
Parts List	7
Schematic Assemblies	7

INTRODUCTION

Scope of Manual

This manual provides instructions for installation, startup, maintenance and spare parts ordering for the FAG and FA Series Filters.

Product Description

Regulating and metering stations need to protect the valves, pressure regulators, meters and so forth from foreign particles present in the gases or, particularly during the initial stages of operation, from debris in newly laid pipes. This is the job of the filter.

This product has been designed to be used with fuel gases of 1st and 2nd family according to EN 437, and with other non aggressive and non fuel gases. For any other gases, other than natural gas, please contact your local sales agent.

The series is available in several versions to meet all application requirements.



Figure 1. Type FA Cartridge Filter

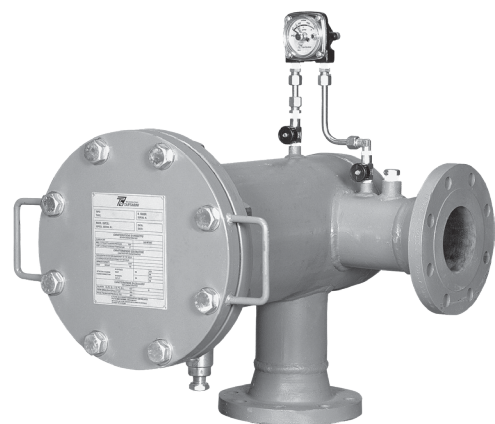

Figure 2. Type FAG Cartridge Filter

FAG and FA Series

TYPE FAG - P.E.D. CATEGORIES AND CHARACTERISTICS

P.E.D. Categories and Fluid Group

Table 1. FAG, FAG-A, FAG-AP and FAG-A-AP Series (Flanged Opening) P.E.D. Categories and Fluid Group

TYPE		CATEGORY	FLUID GROUP
FAG • FAG-A 1 - 1.5 - 2 - 2.5 - 3 - 3.5 - 4	Standard Temperature Version	I, II, III	1
	Low Temperature Version		
FAG • FAG-A 5 - 6	Standard Temperature Version	IV	
	Low Temperature Version		
FAG-AP • FAG-A-AP 0.5 - 1 - 1.5 - 2 - 2.5	Standard Temperature Version	I, II, III	
	Low Temperature Version		
FAG-AP • FAG-A-AP 3 - 3.5 - 4 - 5 - 6	Standard Temperature Version	IV	
	Low Temperature Version		

Note: FAG and FAG-A/0.5 (PS= 6 bar) according to Art. 3.3 (SEP)

FAG, FAG-A/, FAG-AP, and FAG-A-AP/ Series Characteristics

Table 2. Maximum Nozzles Diameter Flanged PN 16 - ANSI 150

TYPE	DN
0.5	50
1	65
1.5	80
2	100
2.5	125
3	150
3.5	150
4	200
5	250
6	300



WARNING

Table 3. Specifications

TYPE	RATING	MAXIMUM WORKING PRESSURE bar	MAXIMUM ALLOWABLE PRESSURE (PS) bar	HYDROSTATIC TEST PRESSURE (PT) bar
FAG/ FAG-A/	PN 16 ANSI 150	6	6	9
FAG-AP FAG-A-AP/	ANSI 150	19	19	30

Minimum/Maximum Allowable Temperature (TS)

Standard Version: -10/60°C

Low Temperature Version: -20/60°C

TYPE FA - P.E.D. CATEGORIES AND CHARACTERISTICS

P.E.D. Categories and Fluid Group

Table 4. FA-11, FA-12 Series (Flanged Opening) , and FA Series (Quick Opening) P.E.D. Categories and Fluid Group

TYPE		CATEGORY	FLUID GROUP
FA-11/ • FA-12/ FA-11-S/ • FA-12-S/ FA-12-AP/ • FA-12-S-AP/ FA-O/11 • FA-O/12 • FA-O/12-AP	Standard Temperature Version	IV	1
	Low Temperature Version		
FA/10-15-20-25-30-40-50 FA-AP/10-15-20-25-30-40-50	Standard Temperature Version		
	Low Temperature Version		

FA-11/, FA-12/, and FA/ Series Characteristics

Nozzles Diameter - Flanged PN 16*, ANSI 150 - 300 - 600

DN 50 - 65 - 80 - 100 - 150 - 200 - 250 - 300 - 350 - 400 - 500*

* Available on request.



WARNING

Table 5. Specifications

TYPE	RATING	MAXIMUM WORKING PRESSURE bar	MAXIMUM ALLOWABLE PRESSURE (PS) bar	HYDROSTATIC TEST PRESSURE (PT) bar
FA/ • FA-11/	PN 16	14	14	1.5 x PS
FA-O/11 • FA-11-S/	ANSI 150	17	17	
FA/ • FA-12/	ANSI 300	30	30	
FA-O/12 • FA-12-S/				
FA-AP • FA-12-AP/	ANSI 600	75	85	
FA-12-S-AP/			90	
FA-O/12-AP				

Minimum/Maximum Allowable Temperature (TS)

Standard Version: -10°/100°C

Low Temperature Version: -20°/100°C

The pressure/temperature limits in this Instruction Manual and any applicable standard or code limitation should not be exceeded.

LABELLING



 BOLOGNA ITALY  Notified body 1370			
TIPO: TYPE:	Note 1	N°FABBR. SERIAL N°	
		DATA: DATE:	Note 2
CARATTERISTICHE DI PROGETTO DESIGN CHARACTERISTICS			
FLUIDO GRUPPO/GROUP FLUID			
(PRESSIONE DI PROGETTO/DESIGN PRESSURE)	PS Bar		Note 3
	PS MPa		
(TEMP.DI PROGETTO/DESIGN TEMPERATURE)	TS °C		Note 4
CARATTERISTICHE COSTRUTTIVE CONSTRUCTIVE CHARACTERISTICS			
RADIOGRAFIA SALDATURE/RADIOGRAPHY OF THE WELD			
EFFICIENZA SALDATURE/EFFICIENCY OF THE WELD			
CAPACITA'/CAPACITY			
PESO/WEIGHT			
ATTACCHI A FLANGIA FLANGE CONNECTION	IN ENTRATA INLET	DN	ANSI Note 5
			PN Note 5
	IN USCITA OUTLET	DN	ANSI Note 5
			PN Note 5
(SUPERFICIE FILTRANTE/FILTERING AREA) m ²			
(PROVA IDRAULICA/HYDRAULIC TEST)	PT Bar		Note 6
	PT MPa		
(PROVA PNEUMATICA/PNEUMATIC TEST)	PN Bar		
	PN MPa		
<small>IL FILTRO DEVE ESSERE PERIODICAMENTE CONTROLLATO E PULITO ONDE EVITARNE L'INTASAMENTO THE FILTER HAS TO BE CHECKED AND CLEANED AT INTERVALS TO AVOID THE CLOGGING</small>			

Figure 3. Label for FA Series



 BOLOGNA ITALY  Notified body 1370		FILTRO TIPO FILTER TYPE	Note 1
		N° FABBR. SERIAL N°	
		DATA DATE	Note 2
DATI DI PROGETTO/DESIGN DATA		DATI COSTRUTTIVI/CONSTRUCTIVE DATA	
FLUIDO GRUPPO GROUP FLUID		CAPACITA' CAPACITY	LITRI / LITRES
PRES.DI PROGETTO DESIGN PRESSURE	PS Bar	PESO WEIGHT	Kg
TEMP.DI PROGETTO DESIGN TEMPERATURE	TS °C	EFFICIENZA SALDATURE EFFICIENCY OF THE WELD	Z=
SUPERFICIE FILTRANTE FILTERING AREA	m ²	ATTACCHI A FLANGIA/FLANGE CONNECTIONS	
DATI DI COLLAUDO/TEST DATA		ENTRATA/INLET	USCITA/OUTLET
PROVA IDRAULICA HYDRAULIC TEST	PT Bar	ANSI	ANSI
	Note 6	Note 5	Note 5
PROVA PNEUMATICA PNEUMATIC TEST	PN Bar	PN	PN
		Note 5	Note 5
<small>IL FILTRO DEVE ESSERE PERIODICAMENTE CONTROLLATO E PULITO ONDE EVITARNE L'INTASAMENTO THE FILTER HAS TO BE CHECKED AND CLEANED AT REGULAR INTERVALS TO AVOID CLOGGING</small>			

Figure 4. Label for FAG Series

Note 1: See "Characteristics"

Note 2: Year of manufacture

Note 3: FAG, FAG-A/, FAG-AP, and FAG-A-AP/ Series
 Maximum PS = 19 bar
 FA-11/, FA-12/, and FA/ Series
 Maximum PS = 90 bar

Note 4: FAG, FAG-A/, FAG-AP, and FAG-A-AP/ Series
 Standard Temperature Range: -10°/60 °C
 Low Temperature Range: -20°/60 °C
 FA-11/, FA-12/, and FA/ Series
 Standard Temperature Range: -10°/100 °C
 Low Temperature Range: -20°/100 °C

Note 5: Available with different flange ratings, see "Characteristics"

Note 6: PT = 1.5 x PS bar

TRANSPORT AND HANDLING

The filters are supplied packaged, transport can take place both horizontally and vertically, on transport saddles or in a cage.

These supports are designed to withstand the weight of the filter, other stresses must be avoided with special ligatures.

The internal parts of the filter, if mounted before transport, are sufficiently rigid, however the equipment must still be handled with care.

The handles or eyebolt on the filter cover must not be used to lift the appliance.

Suitable and consolidated procedures for transport must be followed to avoid any damage to the parts containing pressure.

Particular care must be taken to avoid damage to any pressure accessories installed on the filter..

PRESERVATION AND STORAGE

Stand-alone equipment is delivered with all nozzles blanked and all surfaces completely protected by primer or paint (carbon steel material versions). hence the equipment doesn't need specific precautions for storage, providing to follow the recommendations listed in "Inspection" section on page 4 of this Instruction Manual.

ATEX REQUIREMENTS



WARNING

If the provisions of EN 12186 & EN 12279, national regulations, if any, and specific manufacturer recommendations are not put into practice before installation and if purge by inert gas is not carried out before equipment's start-up and shut-down operations, a potential external and internal explosive atmosphere can be present in equipment & gas pressure regulating/measuring stations/installations.

If a presence of foreign material in the pipelines is foreseen and purge by inert gas is not carried out, the following procedure is recommended to avoid any possible external ignition source inside the equipment due to mechanical generated sparks:

- drainage to safe area via drain lines of foreign materials, if any, by inflow of fuel gas with low velocity in the pipe-work (5m/sec)

In any case,

- provisions of Directive 1999/92/EC and 89/655/EC shall be enforced by gas pressure regulating/measuring station/installation's end user

FAG and FA Series

- with a view to preventing and providing protection against explosions, technical and/or organizational measures appropriate to the nature of the operation shall be taken (e.g. : filling/exhausting of fuel gas of internal volume of the isolated part/entire installation with vent lines to safe area - 7.5.2 of EN 12186 & 7.4 of EN 12279 ; monitoring of settings with further exhaust of fuel gas to safe area ; connection of isolated part/entire installation to downstream pipeline;)
- provision in 9.3 of EN 12186 & 12279 shall be enforced by pressure regulating/measuring station/installation's end user
- external tightness test shall be carried out after each reassembly at installation site using testing pressure in accordance with national rules
- periodical check/maintenance for surveillance shall be carried out complying with national regulations, if any, and specific manufacturer recommendations

OPERATION

The filter does not require any particular attention to operate since it has not dynamic component (static equipment).

Anyhow since the filter internal parts are sensitive to pressure, it is recommended that during startup and shutdown the variation of pressure will be smoothly. To facilitate the operator control a proper set of pressure gauges have to be installed on the nozzles for which it is foreseen by proper coupling connections.

Each filter cartridge is designed to a maximum differential pressure that have not to be exceeded during operation: preventive maintenance is therefore recommended and should be carried out with a frequency which, if not laid down in low, depends on:

- the quality of the gas piped
- the cleanliness and state of conservation of the piping upstream from the filter: in general after starting up the systems for the first time, for example, the maintenance operations will have to be more frequent if the cleanliness in the piping is poor.

INSTALLATION



WARNING

Only qualified personnel shall install a filter. Filtering systems should be installed, operated and maintained in accordance with international and applicable codes and regulations. Following notes and instructions point out, in particular, the “pressure” risk. Installation, operation and maintenance procedures performed by unqualified personnel may result in unsafe operation.

This condition may result in equipment damage or personal injury. If a leak develops

in the system, the escaping gas may accumulate and become a fire or explosion hazard. Immediately call qualified service personnel in case of trouble.

Hazards arising from misuse and misoperating are: Personal injury, equipment damage, or leakage due to escaping gas or bursting of pressure-containing parts may result if the equipment is installed where its capabilities (PS and TS) can be exceeded or where conditions exceed any ratings of the adjacent piping or piping connections.

To avoid this, install the equipment where:

- Service conditions are within unit capabilities.
- Service conditions are within applicable codes, regulations, or standard.
- The unit is protected from exposure to physical damage and/or corrosive substances.
- Suitable pressure-limiting or pressure-relieving devices have been installed in those instances where supply pressure is capable of exceeding the maximum allowable downstream equipment pressure.

National safety standards and established rules shall be applied in filter installation and operation, concerning, in particular, electrical works, fire, and thunderbolt protection.

All means for venting have to be provided in the assemblies where the pressure equipment are installed.

Before installation, check shall be done if service conditions are consistent with use limitations.

Where this product is used:

- provide the cathodic protection and electrical isolation to avoid any corrosion
- the gas shall be cleaned by proper filters/separators/scrubbers to avoid any technical & reasonable hazard of erosion or abrasion for pressure-containing parts

Filters shall be installed in non-seismic area and hasn't to undergo fire and thunderbolt action.

Inspection

Upon arrival at site the equipment must be inspected for eventual damages occurred during transportation. At least, the following points have to be inspected:

- Integrity of nozzles closure and equipment sealing.
- Status of painted surfaces. If paint is damage any touch-up shall be carried out in accordance with the project coating specification.
- Visual check of critical areas such as nozzles, saddles, clips.

Any damage shall be reported to quality control office and eventually to the vendor in order to agree and coordinate any repair work.

The filter have been subject to hydrostatic test at our factory according to Code and Specifications requirements and thoroughly inspected for leakage during the above test.

However, handling during transportation or moving into place may have loose gasketed seals: based upon the above, it is recommended to recheck all bolted connections, if any, prior to startup.

Cleaning

Thoroughly clean and blow all pipe lines to remove scales and other possible foreign material.

Piping Up

The piping established practice shall be follow when installing the filter.

Foundations

Foundation or metallic supports should be suitable to support the equipment and its maximum contents, which may result in stresses caused also by piping connections.

Levelling

The filter should be installed to the correct level, vertically or horizontally, depending on the filters type within the limits agreed by data sheet or specs.

Access

The filter should be installed with sufficient clearance from associated structures and equipment to provide safe, efficient working by operators, and to provide ready access for cleaning, inspection, and maintenance.

Filter is provided with full opening to permit inspection of the interior therefore it has to be so installed that this opening is accessible.

Suitable support should be so arranged by the customer to provide adequate facility for the inspection of every part of the vessel, including platforms and ladders (if necessary).

Flanged and Bolted Joints

Accurate vertical and horizontal alignment, with flange faces parallel, is an important precaution to be taken when making up a flanged joint.

A suggested bolt tightening sequence is to process “three o'clock, nine o'clock, twelve o'clock, six o'clock, etc.”

After have complete the above sequence and additional check have to be performed on all bolts.

The same procedure has to be followed in case of maintenance.

Piping and Connections

To avoid excessive stresses or strains due to piping connections, the following precautions should be taken:

- To avoid stresses arising from nozzle connection, piping should not be forced into alignment when connecting up.
- If the magnitude and direction of external piping forces and moments are known and the nozzles have been designed specifically to these reactions, the above forces and moments are not be exceeded.

Ventilation

Equipment should have adequate ventilation around them, particularly where filters are located indoors.

The ventilation requirements should take into account the type of medium which may escape from the equipment.

Special requirements for lethal material should be agreed with the Authority involved.

Lighting

Where necessary, the illumination level of lighting at the equipment should be sufficient to allow free movement of operating personnel in safety while in operation under normal conditions.

Shipping Covers and Plugs

The shipping covers and plugs (if any) should remain in place until equipment is set in position and ready for piping up.

All openings should be inspected for debris or foreign material that could damage the equipment.

STARTUP AND SHUTDOWN

Filters are particular sensitive to pressure increase very rapidly since the cartridge itself may be damaged.

Pressure should be increased in stages of approximately 10% of operating pressure up to the operating value.

In case of leakage or other inconvenience, the procedure should be immediately stopped and the problem investigated and removed before a new startup.

Gasketed Connections

Before startup and after initial startup, at normal operating pressure and temperature, it is recommended to inspect all gasketed joints for tightness.

FAG and FA Series

Shutting Down

When possible, reduce slowly the pressure in order to avoid damage to the internal.

In no case open the equipment before the pressure is completely released.

In case of sudden high variation of pressure particular attention should be given to the status of internal cartridge.

MAINTENANCE

Filter parts are subject to normal wear and must be inspected periodically and replaced as necessary. The frequency of inspection and replacement depends upon the severity of service condition and upon applicable codes and national standards/rule.

During the inspection of the filter, the equipment with drain valves, these shall be checked that the valves are free of any debris that may restrict the drain flow.

In order to avoid personal injury or equipment damage caused by sudden release of pressure or explosion of accumulate gas, do not attempt any maintenance or disassembly without first isolating the filter from system pressure and relieving all internal pressure from the filter.

Before starting disassembly, carefully release all pressures from the filter. Never loosen the filter body while the unit is under pressure.

Do not remove any pipe plugs from the unit while it is under pressure. Use a gauge to monitor pressure while releasing it. The drain valve is for releasing fluid. Direct the flow stream in a safe direction.

The operation for replacement of the cartridge are of difference type pending type of filter closure. Standard closure provide by the manufacturer are of two types:

- Flanged
- Quick opening

Flanged Type Opening

This type of opening is a standard as any flange connection.

Opening sequence are:

- By means of the drain valve, depressurize the filter.
- After assurance of complete depressurization (by means the pressure gauge), untightening the bolt (key 18) in cross sequence process till all bolts are removed.
- Remove blind flange (key 8) lifting it by the suitable davit (key 28) and move at side.
- Remove nut (key 10) on central bar (key 9) holding cartridge.

- Lift the cartridge by hand and remove it from filter body.
- Inspect gasket or ring seat, the gasket (key 23) and the O-ring (key 12), and replace them if necessary.
- Inspect and clean, if necessary, the internal surface and components.

For reassembly, follow the same procedure vice versa.

Quick Opening

This opening is provided with safe precaution that are integral part of opening itself.

Opening sequence are:

- By means of the drain valve, depressurize the filter.
- Remove protection cover (key 24) at top of filter.
- After assurance of complete depressurization (by means the pressure gauge), remove safety plug (key 29) located on removable cover (key 26).
- Push downward the cover in order to release the sector ring (key 25).
- Remove the ring in sections, first the one with the plug guide.
- Insert the davit (key 28) stud into the proper threaded hole located in center of flat cover locking it with the provided nut.
- Lift the cover (key 26) acting on davit handle till cover become free from filter body.
- Remove nut (key 10) on central bar (key 9) holding cartridge (key 6).
- Lift the cartridge by hand and remove it from filter body.
- Inspect O-ring seat and replace the O-ring (key 12).
- Inspect and clean, if necessary, the internal surface and components.

For reassembly follow same procedure vice versa.

In case the davit is not provided to lift the cover, it is necessary to have a overhead crane in order to operate safety without damaging the gasket surface:

- Insert the eyebolt on threaded hole on cover.
- Lift very carefully the cover so not to damage inside surface of flange body at O-ring location.

SPARE PARTS

Spare parts storage shall be done by proper procedures according to national standard/rules to avoid over aging or any damage.

PARTS LIST

Key Description

1	Head
2	Shell
3	Flange
4	Nozzle
5	Reinforcement plate (only for AP version)
6*	Filtering cartridge
7	Shell flange
8	Flat cover
9	Bolt
10	Nut
11	Washer
12*	O-ring
13	Bottom plate for cartridge
14	Drain
15	Eyebolt
16	Thredolet
17	Stud
18	Nut
19	Pipe
20	Pipe
21	Top plate for cartridge
22	Hinge
23*	Gasket
24	Plate
25	Sector
26	Cover
27	Container head
28	Davit
29	Safety plug
30*	O-ring

SCHEMATIC ASSEMBLIES

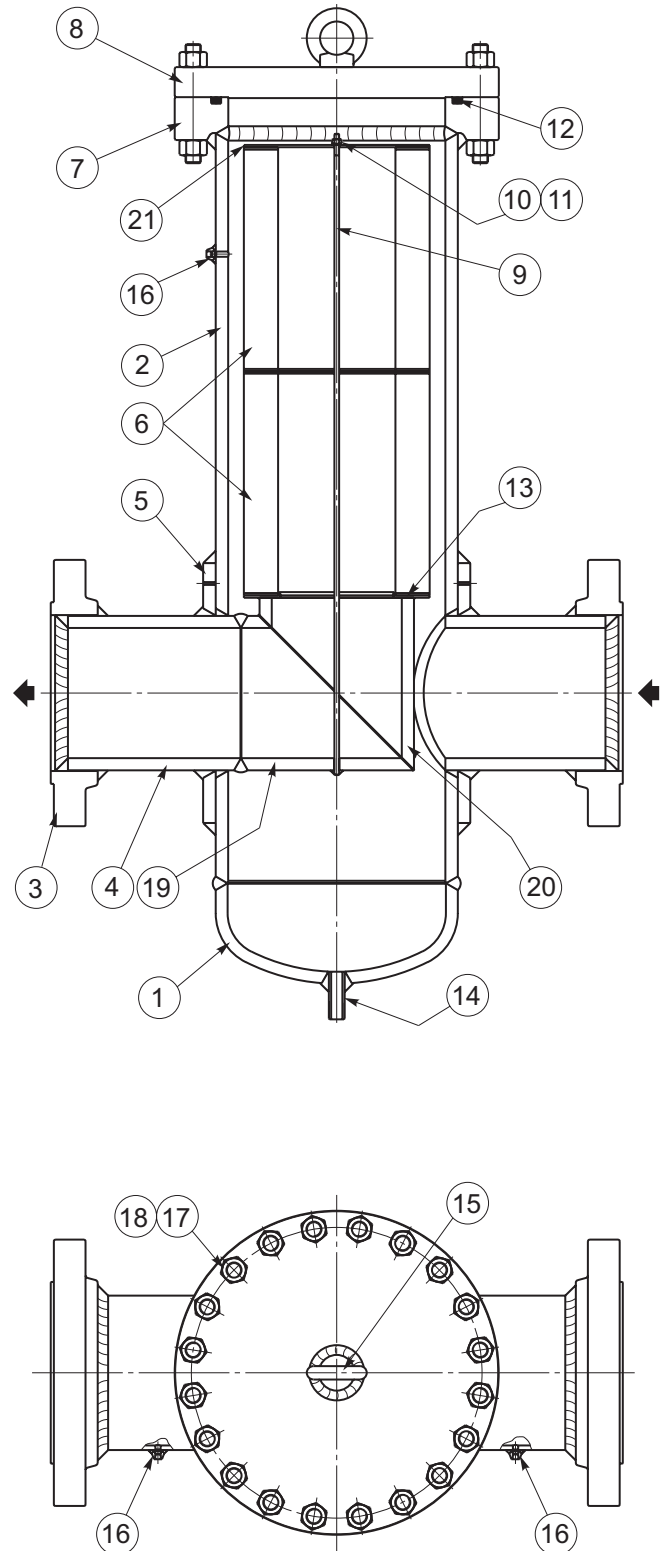

Parts marked with (*) are supplied as spare parts.

To order the spare parts, it is necessary to communicate us the type of the filter and its serial number.

Figure 5. FA Series Assembly

FAG and FA Series

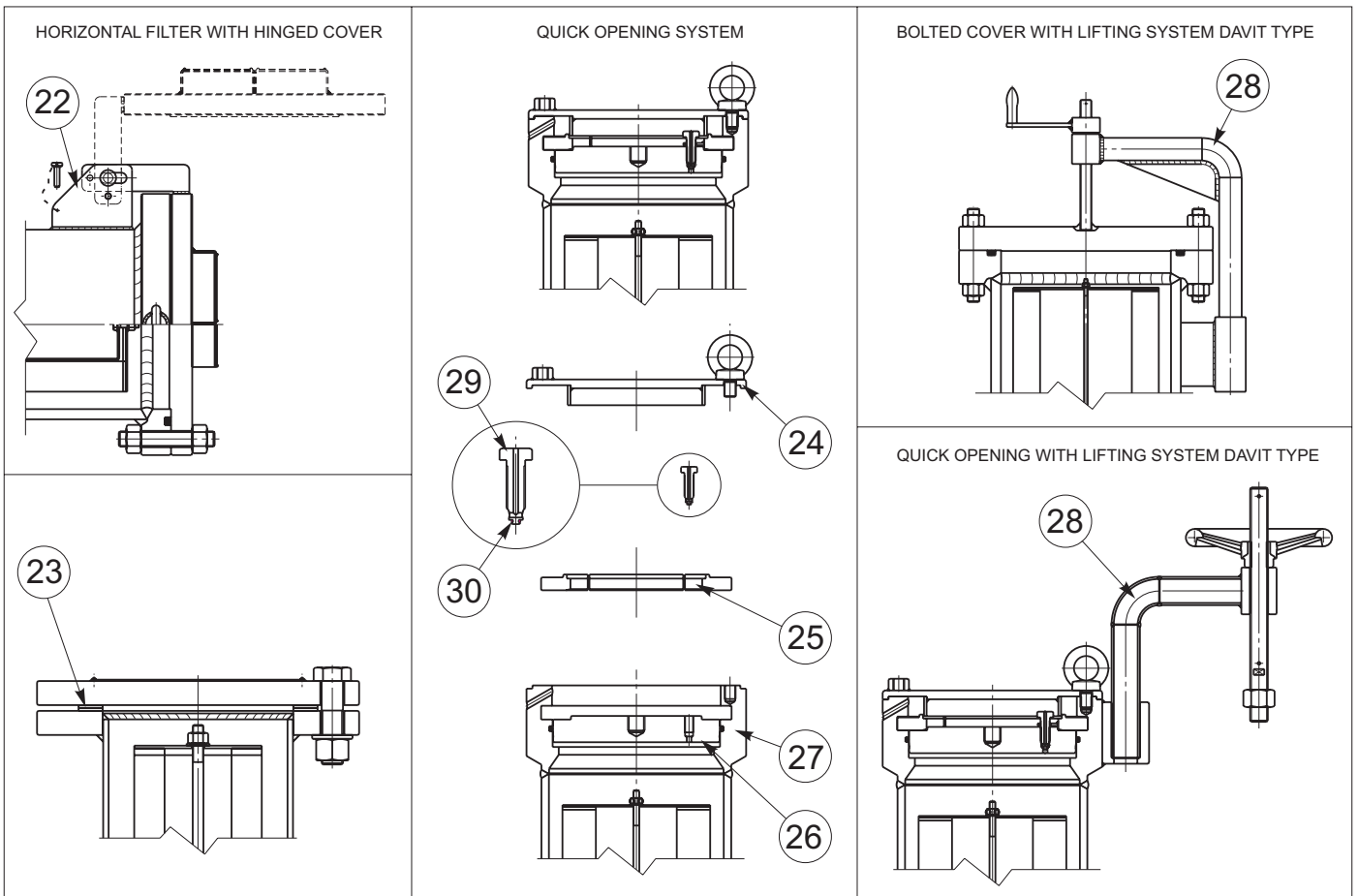

Figure 5. FA Series Assembly (continued)

✉ Webadmin.Regulators@emerson.com

🔍 Tartarini-NaturalGas.com

📘 Facebook.com/EmersonAutomationSolutions

🌐 LinkedIn.com/company/emerson-automation-solutions

🐦 Twitter.com/emr_automation

Emerson Automation Solutions

Americas

McKinney, Texas 75070 USA
T +1 800 558 5853
+1 972 548 3574

Europe

Bologna 40013, Italy
T +39 051 419 0611

Asia Pacific

Singapore 128461, Singapore
T +65 6777 8211

Middle East and Africa

Dubai, United Arab Emirates
T +971 4 811 8100

O.M.T. Officina Meccanica Tartarini S.R.L., Via P. Fabbri 1, I-40013 Castel Maggiore (Bologna), Italy
R.E.A 184221 BO Cod. Fisc. 00623720372 Part. IVA 00519501209 N° IVA CEE IT 00519501209,
Cap. Soc. 1.548 000 Euro i.v. R.I. 00623720372 - M BO 020330

D103669X012 © 2014, 2020 Emerson Process Management Regulator Technologies, Inc. All rights reserved. 03/2020.

The Emerson logo is a trademark and service mark of Emerson Electric Co. All other marks are the property of their prospective owners. Tartarini™ is a mark of O.M.T. Officina Meccanica Tartarini s.r.l., a business of Emerson Automation Solutions.

The contents of this publication are presented for information purposes only, and while effort has been made to ensure their accuracy, they are not to be construed as warranties or guarantees, express or implied, regarding the products or services described herein or their use or applicability. All sales are governed by our terms and conditions, which are available on request. We reserve the right to modify or improve the designs or specifications of our products at any time without notice.

Emerson Process Management Regulator Technologies, Inc does not assume responsibility for the selection, use or maintenance of any product. Responsibility for proper selection, use and maintenance of any Emerson Process Management Regulator Technologies, Inc. product remains solely with the purchaser.



EMERSON™