

Type FLV Axial Control Valve

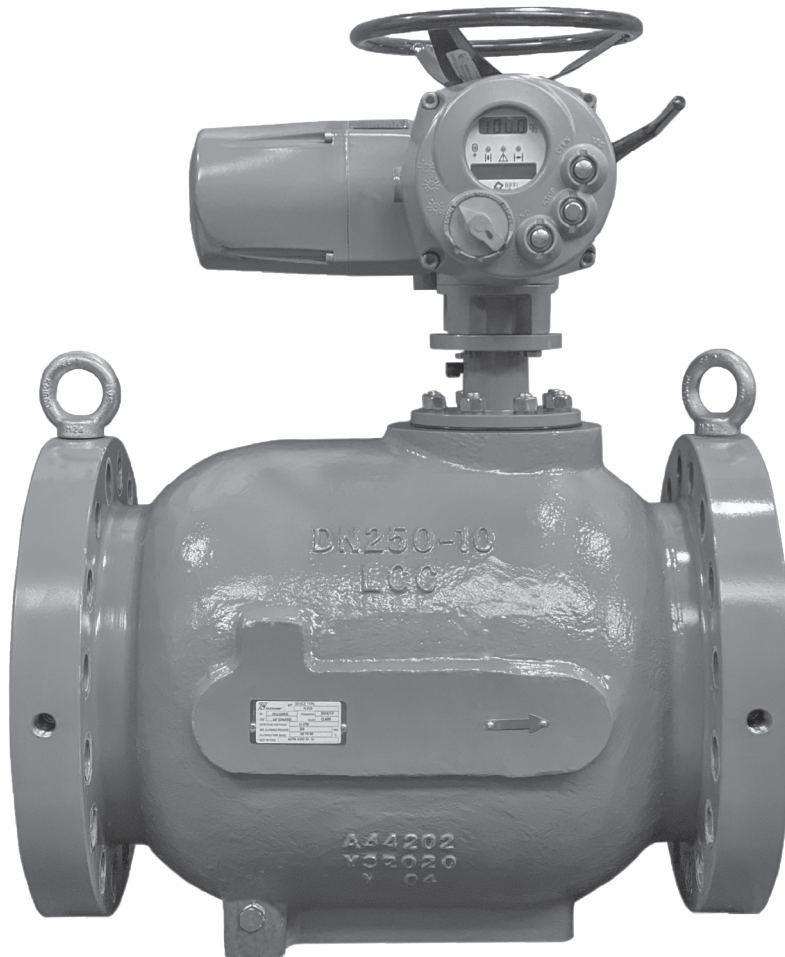

Figure 1. Type FLV Axial Control Valve with Electric Actuator

Features

- Single-piece, integral flanged and ergonomic design of anti rolling feature in the body
- Greater flow rates than “top entry” control valve
- Linear and equal percentage flow characteristic
- Shorter bonnet for rotary actuator than that of linear actuator
- High accuracy and low drive torque
- Proven Whisper Trim™ technology for noise reduction
- In-line maintenance of seat ring

Introduction

Type FLV axial control valve is designed to meet a wide range of natural gas transmission, storage and distribution applications.

Main Reference Standards:

- IEC 60534
- GB/T 17213
- JB/T 7387

Type FLV

Specifications

The Specifications section gives some general specifications for the Type FLV axial control valve. The nameplates give detailed information for a specific control valve as built in the factory.

Main Valve

Body Sizes

DN 150 to 300 / NPS 6 to 12

End Connection Styles

CL300 RF and CL600 RF

Maximum Inlet Pressure⁽¹⁾

CL300 RF: 51.7 barg / 750 psig

CL600 RF: 103 barg / 1500 psig

Maximum Differential Pressure⁽¹⁾

CL300 RF: 51.7 barg / 750 psig

CL600 RF: 103 barg / 1500 psig

Flow Coefficient

See Table 1

Inherent Flow Characteristics

Linear

Equal Percentage

Flow Direction

Flow to Open

Shut Off Leakage Class

VI per IEC 60534-4

Accuracy

Class 1 with electric actuator per JB/T 7387

Cage Type

Window Cage⁽²⁾

Multi-path Cage

Silencer Cage for Noise Reduction

Main Valve (continued)

Working Temperature Capabilities⁽¹⁾

Standard Version, Nitrile (NBR) or Fluorocarbon (FKM): -10 to 60°C / 14 to 140°F

Low Temperature Version, Nitrile (NBR): -20 to 60°C / -4 to 140°F

Construction Materials

Body: LCC Steel

Trim: Stainless steel, Carbon steel (optional) and Aluminum-Bronze

O-ring: Nitrile (NBR) (standard) or

Fluorocarbon (FKM) (optional)

Disk/Seat Ring: Polytetrafluoroethylene (PTFE)

Electric Actuator

Input Signal

4 to 20 mA

Power

380V AC / 50Hz

Explosion Proof

ExdIIBT4

IP Code

IP66 or IP68 (7 m, 72 hours)

Failure Position

Lock-in-Last Position

Options

Body Drainage Hole and Plug

Approximate Weights

See Tables 3 and 4

1. The pressure/temperature limits in this Bulletin or any applicable standard limitation should not be exceeded.

2. Do not exceed dP/P1 ratio of 0.60.

Product Description

Type FLV axial control valve with flow to open direction is designed according to IEC60534 standard. It is used as pressure or flow control valve on natural gas transmission, storage and distribution. Type FLV axial control valve is designed to be used with non-corrosive fuel gases of 1st and 2nd family per EN 437. For any other gases, other than natural gas, please contact your local sales office.

A multi-path or silencer cage is recommended for high differential pressure applications where high noise is expected to occur with standard window cages. Type FLV axial control valve comes with an electric actuator as standard; however, it can be fitted with pneumatic actuator on special request.

Type FLV is designed with an easy to access seat ring that can be removed from the valve body without removing the control valve from the pipeline. For this, a special spacer is installed upstream of the control valve. This spacer can be removed easily by loosening the inlet line bolting. Once the spacer is removed from its position, the disk holder assembly that contains the PTFE disk can be easily unscrewed from the valve body. See Figure 3.

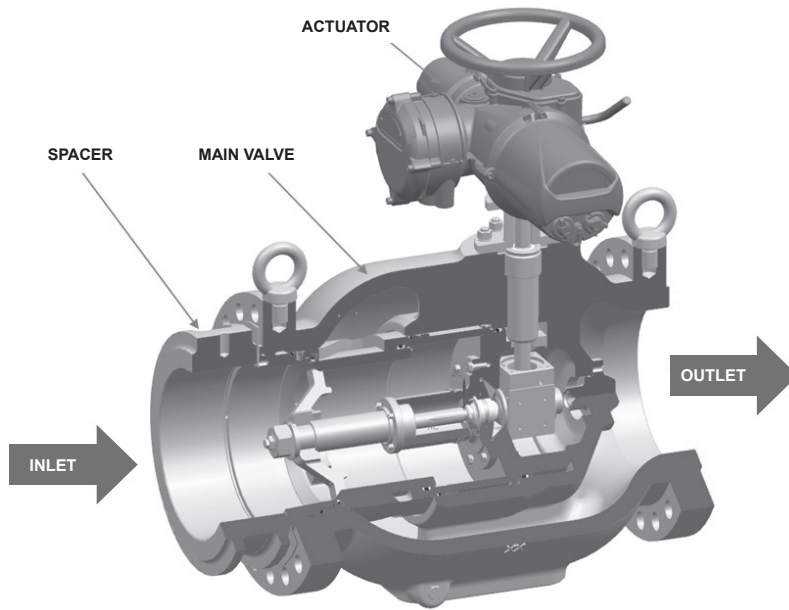

Figure 2. Type FLV Flow Orientation

Table 1. Type FLV Sizing Parameters

CAGE TYPE		VALVE SIZE, DN / NPS							
		150 / 6		200 / 8		250 / 10		300 / 12	
LINEAR WINDOW CAGE (DP/P1<0.6)	% Opening	15.6*	100	15.0*	100	11.9*	100	18.3*	100
	C _g	98	20,456	205	37,000	247	58,000	430	82,000
	C _v	2.8	604	6.0	1150	7	1750	14	2650
	C ₁	35.0	33.9	34.2	32.2	35.3	33.1	31.9	30.9
	X _T	0.774	0.730	0.738	0.654	0.787	0.694	0.641	0.605
	F _d	0.053	0.143	0.064	0.126	0.060	0.125	0.584	0.112
LINEAR MULTIPATH CAGE	% Opening	16.3*	100	15.7*	100	12.5*	100	14.8*	100
	C _g	145	18,900	200	35,000	296	53,000	260	63,800
	C _v	4.0	535	6	1100	8	1600	8	2100
	C ₁	36.3	35.3	36.4	31.8	37.0	33.1	32.5	30.4
	X _T	0.831	0.789	0.836	0.640	0.865	0.694	0.668	0.583
	F _d	0.101	0.033	0.094	0.022	0.081	0.018	0.094	0.034
EQUAL PERCENTAGE WINDOW CAGE (DP/P1<0.6)	% Opening	16.8*	100	18.1*	100	13.7*	100	17.3*	100
	C _g	135	17,888	165	30,476	235	46,963	340	64,500
	C _v	3.6	507	5.0	912	7	1622	10	2136
	C ₁	37.5	35.3	33.0	33.4	36.2	29.0	32.7	30.2
	X _T	0.889	0.790	0.688	0.710	0.826	0.530	0.676	0.576
	F _d	0.194	0.399	0.404	0.373	0.289	0.398	0.420	0.371
EQUAL PERCENTAGE MULTIPATH CAGE	% Opening	17.9*	100	16.6*	100	13.8*	100	15.9*	100
	C _g	102	12,818	200	24,464	288	38,598	330	55,436
	C _v	3.5	403	7.5	897	8	1409	11	1875
	C ₁	29.1	31.8	26.7	27.3	34.3	27.4	30.8	29.6
	X _T	0.537	0.640	0.450	0.470	0.743	0.470	0.601	0.550
	F _d	0.230	0.039	0.191	0.028	0.202	0.022	0.213	0.037

* Do not operate below this minimum value as seat erosion may result.

Type FLV

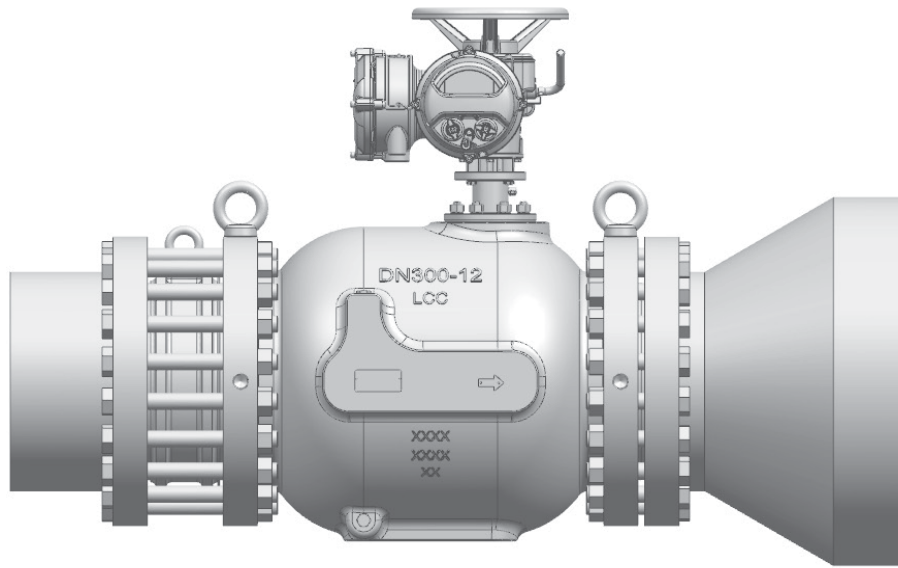

TYPE FLV WITH INLET SPACER INSTALLED IN POSITION

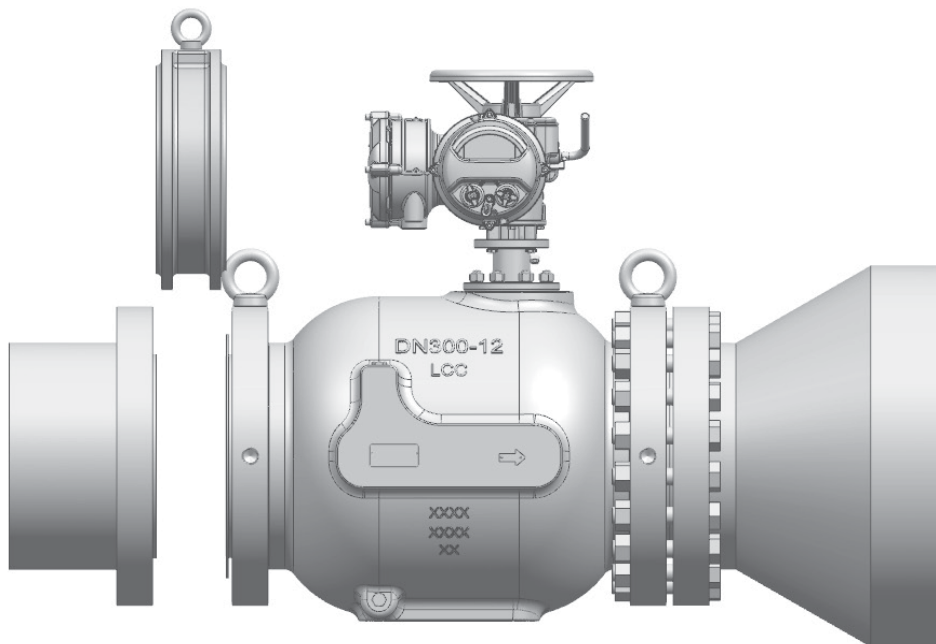

TYPE FLV WITH INLET SPACER UNINSTALLED FROM ITS POSITION

Figure 3. Type FLV Installation

Principle of Operation

Type FLV axial control valve regulates the gas flow in accordance to the desired set system pressure and/or flow rate. Changes in set pressure and/or flow rate are sensed by respective sensors and fed to a controller (PLC). The controller in-turn sends the command signal to the electric actuator which rotates and moves the control valve shaft and plug assembly to regulate the gas flow.

When the downstream demand increases, the downstream pressure will decrease momentarily. The controller will send a command signal to the electric actuator to rotate anti-clockwise to open the valve more to allow more gas to flow and maintain the downstream pressure.

Conversely, when the downstream demand decreases, the downstream pressure will increase momentarily. The controller will send a command signal to the electric actuator to rotate clockwise to close the valve to reduce the gas to flow and maintain the downstream pressure.

Table 2. Gas Conversion

GAS	RELATIVE DENSITY (d)	FACTOR (F)
Air	1	0.78
Butane	2.01	0.55
Propane	1.53	0.63
Nitrogen	0.97	0.79

Installation

Type FLV axial control valve must be installed in horizontal pipes with the actuator on top and per the flow arrow mark shown on the body. See Figure 3.

Install the control valve where service conditions are within unit capabilities specified in specifications on page 2 and are within applicable codes, regulations or standard.

For safety during shutdown, block valve will be required immediately upstream and downstream of the control valve.

Capacity Information

To find approximate flow capacity and valve diameter, perform the following procedures:

Calculation Procedures

Symbols

Q = Natural gas flow rate in (Stm³/h)

P₁ = Absolute inlet pressure in bar

P₂ = Absolute outlet pressure in bar

C_g = Flow coefficient

C₁ = Body shape factor

d = Relative density of the gas

Flow Rate Q

Calculate the required C_g with the following formula:

Sub-critical state with $P_2 > \frac{P_1}{2}$

$$Q = 0.525 \times C_g P_1 \sin \left(\frac{3417}{C_1} \sqrt{\frac{\Delta P}{P_1}} \right) \text{DEG}$$

Critical state with $P_2 \leq \frac{P_1}{2}$

$$Q = 0.525 \times C_g P_1$$

For other gases with different densities, the flow rate calculated with the above formulas must be multiplied with the correction factor:

$$F = \sqrt{\frac{0.6}{d}}$$

DN Sizes

Calculate the required C_g with the following formula:

Sub-critical state with $P_2 > \frac{P_1}{2}$

$$C_g = \frac{Q}{0.525 \times P_1 \sin \left(\frac{3417}{C_1} \sqrt{\frac{\Delta P}{P_1}} \right) \text{DEG}}$$

Critical state with $P_2 \leq \frac{P_1}{2}$

$$C_g = \frac{Q}{0.525 \times P_1}$$

The above formulas apply to natural gas flow rate only. If the flow rate value (Q) refers to other gasses, divide it by the correction factor F (see Table 2).

After finding the DN of the valve, check that gas speed at the outlet flange does not exceed 150 m/sec, using the following formula:

$$V = 345.92 \times \frac{Q}{DN^2} \times \frac{1 - 0.002 \times P_u}{1 + P_u}$$

V = velocity (m/s)

Q = Natural gas flow rate in (Stm³/h)

DN = Valve nominal diameter (mm)

P_u = Inlet pressure in relative value (bar)

Type FLV

Dimensions and Weights

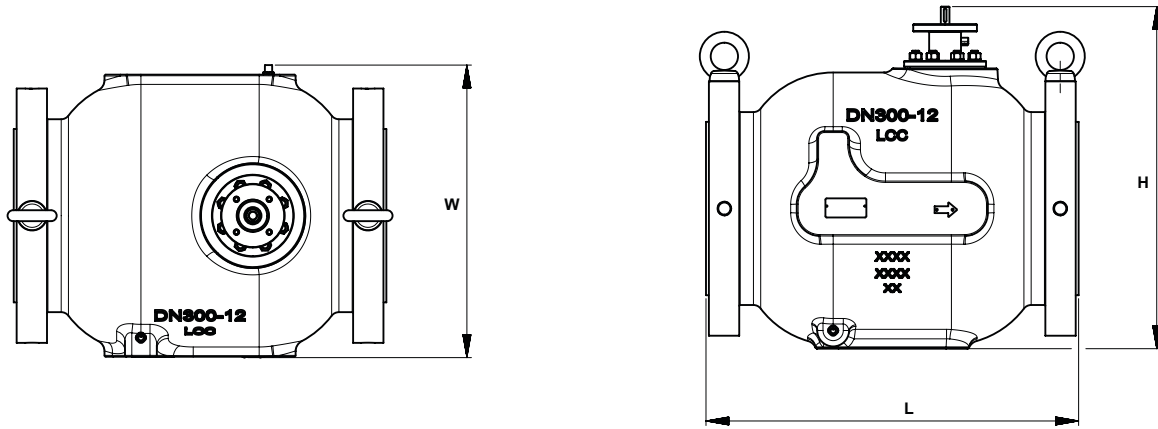

TYPE FLV MAIN VALVE

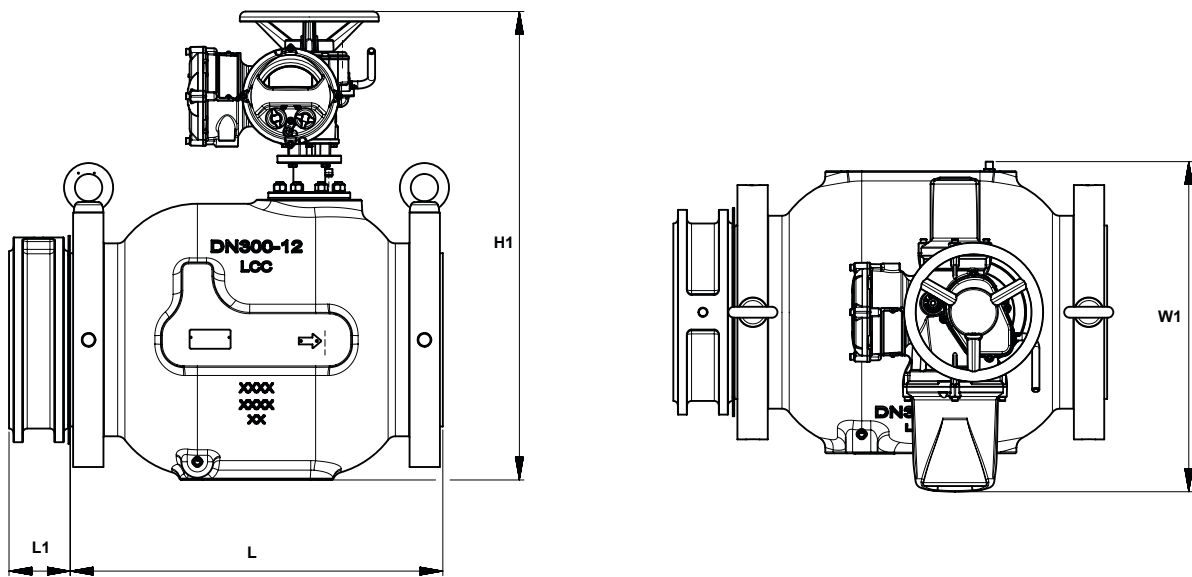

TYPE FLV WITH SPACER AND ELECTRIC ACTUATOR

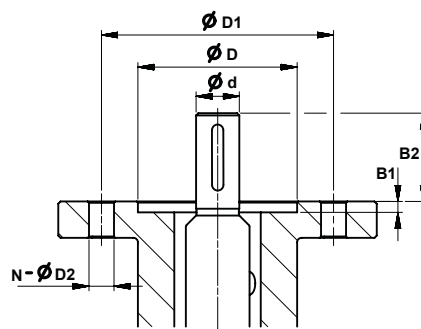

TYPE FLV BONNET

Figure 4. Dimensions and Weights

Table 3. Type FLV Main Valve Dimensions and Weights

VALVE SIZE, DN / NPS	PRESSURE CLASS	L		W		H		WEIGHT	
		mm	In.	mm	In.	mm	In.	kg	lbs
150 / 6	CL300 RF	473	18.62	380	14.96	500	19.69	185	408
	CL600 RF	508	20.00	380	14.96	500	19.69	208	459
200 / 8	CL300 RF	568	22.36	450	17.72	577	22.72	325	716
	CL600 RF	610	24.02	450	17.72	577	22.72	345	761
250 / 10	CL300 RF	708	27.87	532	20.94	666	26.22	510	1124
	CL600 RF	752	29.61	532	20.94	666	26.22	586	1292
300 / 12	CL300 RF	775	30.51	630	24.80	751.8	29.60	752	1658
	CL600 RF	819	32.24	630	24.80	751.8	29.60	832	1834

Table 4. Type FLV with Spacer and Electric Actuator Dimensions and Weights

VALVE SIZE, DN / NPS	PRESSURE CLASS	L1		W1 ⁽¹⁾		H1 ⁽¹⁾		WEIGHT	
		mm	In.	mm	In.	mm	In.	kg	lbs
150 / 6	CL300 RF	125	4.92	561	22.09	791	31.14	227	500
	CL600 RF	125	4.92	561	22.09	791	31.14	263	580
200 / 8	CL300 RF	125	4.92	561	22.09	869	34.21	366	807
	CL600 RF	125	4.92	561	22.09	869	34.21	409	902
250 / 10	CL300 RF	125	4.92	564	22.20	959	37.76	575	1268
	CL600 RF	125	4.92	564	22.20	959	37.76	664	1464
300 / 12	CL300 RF	135	5.31	619	24.37	1045	41.14	832	1834
	CL600 RF	135	5.31	619	24.37	1045	41.14	922	2033

1. This dimension is based on actuator model "BIFFI:ICON-010R/30". This dimension may be variable for other actuators.

Table 5. Type FLV Bonnet Dimensions

VALVE SIZE, DN / NPS	PRESSURE CLASS	d		D		D1		D2		B1		B2		NUMBER OF HOLES
		mm	In.	mm	In.	mm	In.	mm	In.	mm	In.			
150 / 6	CL300 RF and CL600 RF	19	0.75	70	2.76	102	4.02	11	0.43	4.8	0.19	39	1.57	4
200 / 8														
250 / 10														
300 / 12														

Type FLV

Ordering Information

Prior to ordering, complete the ordering guide to cross check your valve selections. Refer to Specifications section in page 2 for details. Review the description against each specification and the information in each referenced table or figure. Specify your choice wherever you find multiple choices.

Ordering Guide

Body Size

- DN 150 / NPS 6***
- DN 200 / NPS 8***
- DN 250 / NPS 10***
- DN 300 / NPS 12***

End Connection

- CL300 RF Flanged***
- CL600 RF Flanged***

O-ring Material

- Fluorocarbon (FKM), -10 to 60°C / 14 to 140°F***
- Nitrile (NBR), -20 to 60°C / -4 to 140°F***

Flow Characteristic

- Linear***
- Equal Percentage***

Cage Options

- Window Cage, $dP/P_1 \leq 0.6$ ***
- Multi-path Cage**
- Silencer Cage for Noise Reduction*

Control Valve Quick Order Guide	
***	Readily Available for Shipment
**	Allow Additional Time for Shipment
*	Special Order, Constructed from Non-Stocked Parts. Consult Your local Sales Office for Availability.
Availability of the product being ordered is determined by the component with the longest shipping time for the requested construction.	

 Webadmin.Regulators@emerson.com

 Tartarini-NaturalGas.com

 Facebook.com/EmersonAutomationSolutions

 LinkedIn.com/company/emerson-automation-solutions

 Twitter.com/emr_automation

Emerson Automation Solutions

Americas

McKinney, Texas 75070 USA
T +1 800 558 5853
+1 972 548 3574

Europe

Bologna 40013, Italy
T +39 051 419 0611

Asia Pacific

Singapore 128461, Singapore
T +65 6777 8211

Middle East and Africa

Dubai, United Arab Emirates
T +971 4 811 8100

Actuator

- Electric Actuator, 380V AC / 50 HZ***
- Electric Actuator, other voltages**
Please specify: _____
- Electric Actuator: Input signal, 4 to 20 mA***
- Electric Actuator: Input signal, others**
Please specify: _____
- Pneumatic Actuator*

Specification Worksheet

Application:

Specific Use _____

Line Size _____

Gas Type and Specific Gravity _____

Gas Temperature _____

Does the Application Require Overpressure Protection?

Yes No If yes, which is preferred:

Relief Valve Monitor Regulator Shutoff

Device _____

Is overpressure protection equipment selection

assistance desired? _____

Pressure:

Maximum Inlet Pressure (P_{1max}) _____

Minimum Inlet Pressure (P_{1min}) _____

Downstream Pressure Setting(s) (P_2) _____

Flow:

Maximum Flow (Q_{max}) _____

Minimum Flow (Q_{min}) _____

Performance Required:

Accuracy Requirements? _____

Need for Extremely Fast Response? _____

Other Requirements: _____

D104500X012 © 2020 Emerson Process Management Regulator Technologies, Inc. All rights reserved. 10/20.
The Emerson logo is a trademark and service mark of Emerson Electric Co. All other marks are the property of their prospective owners.
Tartarini™ is a mark owned by O.M.T. Officina Meccanica Tartarini s.r.l., a business of Emerson Automation Solutions.
Whisper Trim™ is owned by one of the companies in the Emerson Automation Solutions business unit of Emerson Electric Co.

The contents of this publication are presented for informational purposes only, and while every effort has been made to ensure their accuracy, they are not to be construed as warranties or guarantees, express or implied, regarding the products or services described herein or their use or applicability. All sales are governed by our terms and conditions, which are available upon request. We reserve the right to modify or improve the designs or specifications of such products at any time without notice.

Emerson Process Management Regulator Technologies, Inc does not assume responsibility for the selection, use or maintenance of any product. Responsibility for proper selection, use and maintenance of any Emerson Process Management Regulator Technologies, Inc. product remains solely with the purchaser.

O.M.T. Officina Meccanica Tartarini S.R.L., Via P. Fabbri 1, I-40013 Castel Maggiore (Bologna), Italy
R.E.A 184221 BO Cod. Fisc. 00623720372 Part. IVA 00519501209 N° IVA CEE IT 00519501209,
Cap. Soc. 1.548 000 Euro i.v. R.I. 00623720372 - M BO 020330

Francel SAS, 3 Avenue Victor Hugo, CS 80125, Chartres 28008, France
SIRET 552 068 637 00057 APE 2651B, N° TVA : FR84552068637, RCS Chartres B 552 068 637,
SAS capital 534 400 Euro

