

TUBE BUNDLE HEAT EXCHANGERS

CNF - CN - CF - SV Series



CNF - CN - CF - SV Heat Exchangers

Tube Bundle Heat Exchangers

In the gas pressure reduction process by the “Joule-Thomson” effect, temperature drops considerably (about 0.5°C per reduction bar are estimated).

This fall in gas temperature can damage equipment due to formation of dangerous ice crystals produced by water vapor in the gas.

In first stage stations in particular, gas must be heated before pressure is reduced, since high pressure changes are usually involved.

We recommend that, after reduction, gas temperature should not be below 5°C.

One of the best established methods of heating gas in reduction stations is to use heat exchangers employing hot water or steam as their thermal carrier fluid.

The heat exchangers we produce are sized and designed to meet a very wide range of system requirements, and include all connections for accessories.



CNF - CN - CF - SV Heat Exchangers

Operation

Gas flowing at heat exchanger inlet is deflected by a separator. Gas passes through the tube plate and flows along the tube bundle. Here, thermal exchange with the thermal carrier fluid occurs.

As a result, gas reaches outlet at an adequately increased temperature.

The thermal carrier fluid (water or steam) enters the upper part and flows out into the lower part of the exchanger through appropriate outlets. The fluid meets a set of baffles inside the shell, which are positioned to prolong its path and thus encourage thermal exchange with gas.

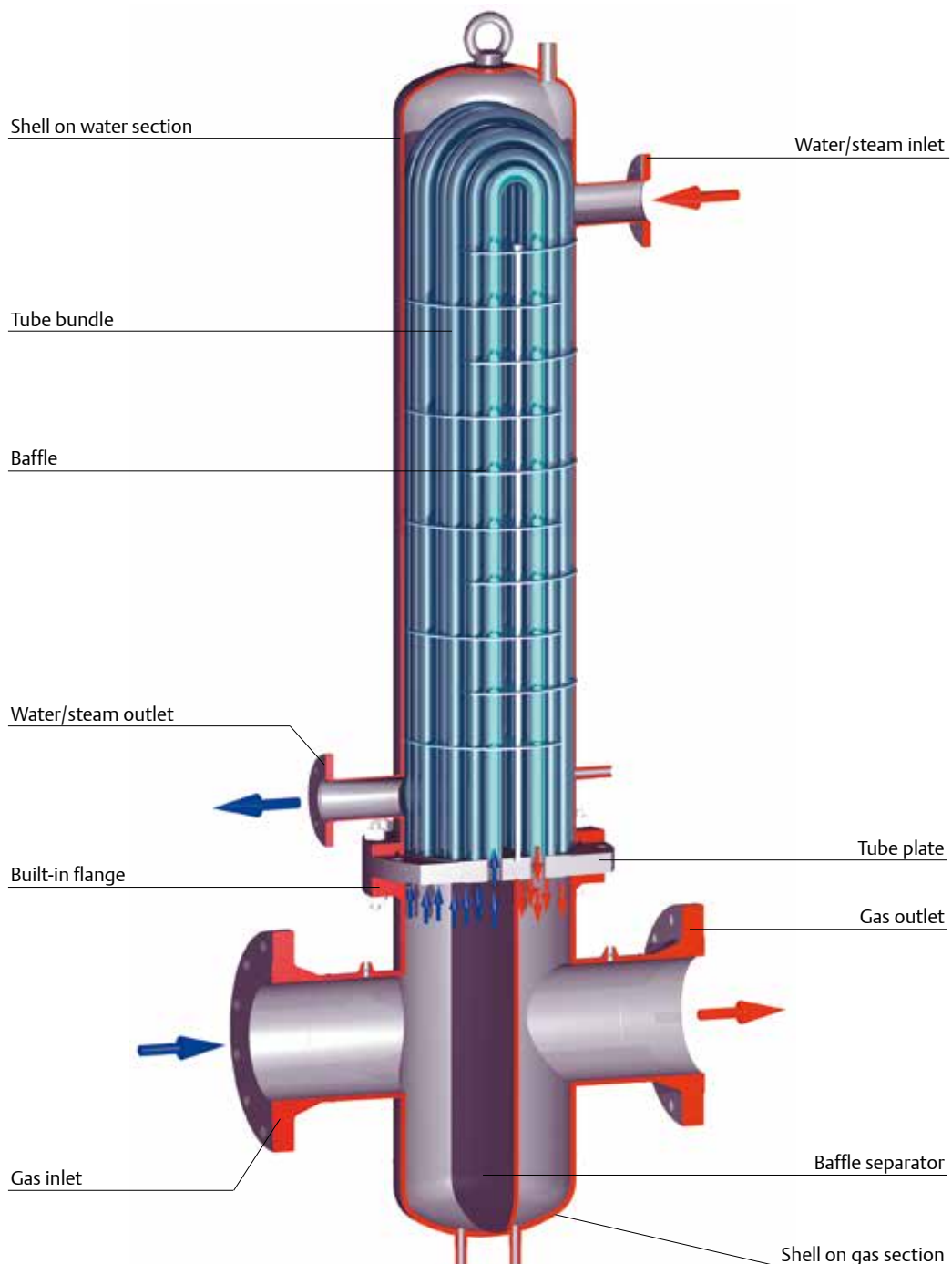

CNF - CN - CF - SV Heat Exchangers

Features

Applications For preheating natural gas in first reception and reduction stations and for all natural gas, or other non aggressive gases, heating requirements.

Models Water as thermal carrier fluid:
CNF - CN - CF series

Steam as thermal carrier fluid:
SV series

Technical Features

- Tube bundle heat exchangers using U-tubes (BEU)
- Tube bundle with inspection facility
- Gas in tubes section, thermal carrier fluid in shell section
- Axial connections in gas section
- Designed for installation of automatic air escape
- Designed for installation of relief valve

Functional Features

Maximum water temperature

CNF - CN - CF Series: 90 °C

Maximum water temperature

SV Series: 120 °C

Higher temperature version on request

Installation Heat exchangers designed for installation with vertical tube bundle

Can be supplied with different tube bundle configurations on request

Materials	Shell on gas section	Steel
	Flange	Steel
	Built-in flange	Steel
	Tube plate	Steel
	Stud bolts/Nuts	Steel
	Connections	Steel
	Seals	Nitrile rubber NBR



Heat Exchanger Choice

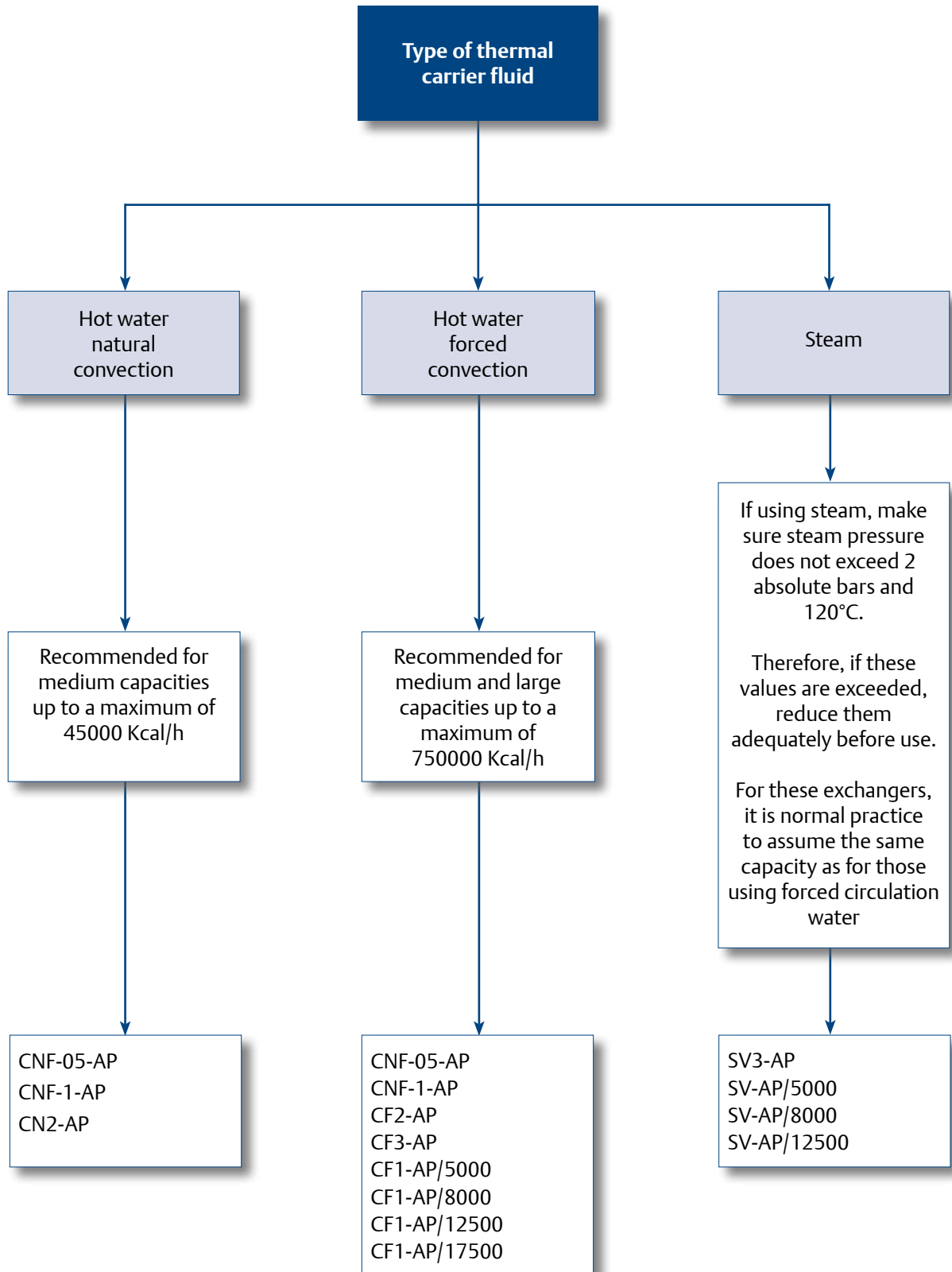

CNF - CN - CF - SV Heat Exchangers

CNF - CN - CF Series

Connections

Gas Side			
Rating	Design Pressure (bar)	Hydrostatic Test (bar)	Pneumatic Test (bar)
ANSI 300	45	57	7
ANSI 600	90	113	7

Water Side		
Rating	Design Pressure (bar)	Hydrostatic Test (bar)
UNI/DIN PN 6	5	7.5

Accessories		
Item	Quantity	Description
1	1	Coupling 3/8" GAS-F
2	3	Thredolet 1/2" NPT
3	3	Nipple 1/2" GAS-M
4	2	Thredolet 1/4" NPT

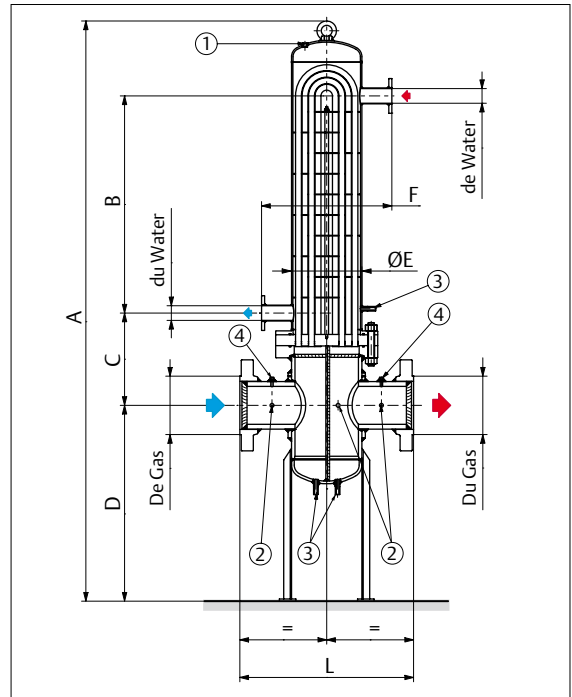

Dimensions (mm) and Weights (kg)

Type	De max	Du max	de max	du max	A	B	C	D*	Ø E	F	L	Weight
CNF-05-AP	50	50	50	50	1880	700	220	800	141.3	350	500	90
CNF-1-AP	100	100	65	65	1930	710	247	800	193.7	400	550	200
CN2-AP	125	125	80	80	2470	1150	320	800	219.1	420	650	255
CF2-AP	125	125	80	80	2470	1150	320	800	219.1	420	650	255
CF3-AP	150	150	80	80	2595	1100	430	800	273	600	800	310
CF1-AP/5000	200	200	80	80	2540	1000	425	800	324	600	800	600
CF1-AP/8000	250	250	80	80	2995	1050	580	1000	457	800	1100	900
CF1-AP/12500	300	300	150	150	3050	950	660	1000	508	800	1200	1300
CF1-AP/17500	350	350	200	200	3315	950	820	1000	560	800	1250	1350

* Proposed height, variable according to installation needs.

Thermal Features

Type	Exchange Surface (m ²)	Water Side Volume (liters)	Gas Side Maximum Volume (liters)	Thermal Capacity (Kcal/h)
CNF-05-AP	0.6	11	3.8	14500
CNF-1-AP	1.4	23	12	29000
CN2-AP	2	30	25.5	48500
CF2-AP	2	30	25.5	64500
CF3-AP	3.5	55	42	100000
CF1-AP/5000	5	68	75	161000
CF1-AP/8000	11.5	120	160	340000
CF1-AP/12500	15	200	250	485000
CF1-AP/17500	18	281	336	750000

Thermal capacities are calculated for the following conditions:

- gas inlet pressure 5-75 bar
- gas reduced pressure 4 bar
- inlet gas temperature 5 °C
- after reduction gas temperature 5 °C

For different conditions contact our engineering department.

CNF - CN - CF - SV Heat Exchangers

SV Series

Connections

Gas Side			
Rating	Design Pressure (bar)	Hydrostatic Test (bar)	Pneumatic Test (bar)
ANSI 300	45	57	7
ANSI 600	90	113	7

Steam Side		
Rating	Design Pressure (bar)	Hydrostatic Test (bar)
UNI/DIN PN 6	5	7.5

Accessories		
Item	Quantity	Description
1	1	Coupling 3/8" GAS-F
2	3	Thredolet 1/2" NPT
3	3	Nipple 1/2" GAS-M
4	2	Thredolet 1/4" NPT

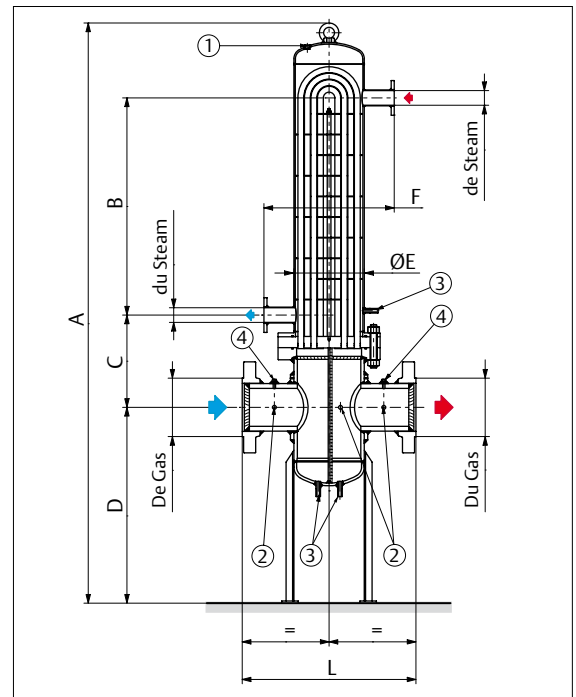

Dimensions (mm) and Weights (kg)

Type	De max	Du max	de max	du max	A	B	C	D*	Ø E	F	L	Weight
SV3-AP	125	125	80	80	2498	1100	430	800	273	600	800	310
SV-AP/5000	150	150	80	80	2485	1000	400	800	324	600	800	600
SV-AP/8000	200	200	80	80	3000	1050	580	1000	457	800	1100	1100
SV-AP/12500	250	250	125	125	3019	950	660	1000	508	800	1200	1150

* Proposed height, variable according to installation needs.

Thermal Features

Type	Exchange Surface (m ²)	Steam Side Volume (liters)	Gas Side Volume (liters)	Thermal Capacity (Kcal/h)
SV3-AP	3.5	25	40	100000
SV-AP/5000	5	68	75	161000
SV-AP/8000	11.5	120	160	340000
SV-AP/12500	15	200	250	485000

Thermal capacities are calculated for the following conditions:

- gas inlet pressure 5-75 bar
- gas reduced pressure 4 bar
- inlet gas temperature 5 °C
- after reduction gas temperature 5 °C

For different conditions contact our engineering department.

Pre-Heating Systems

Water Pre-Heating

- 1 Boiler with temperature probe
- 2 On-off valve
- 3 Pump
- 4 Expansion tank
- 5 3-way non-return valve for water
- 6 Heat exchanger

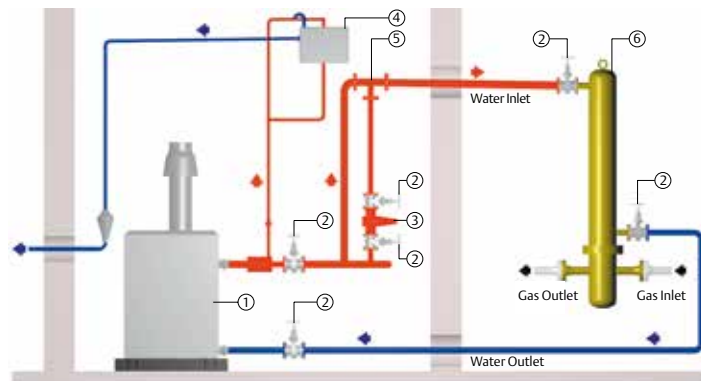

Steam Pre-Heating

- 1 On-off valve
- 2 Y-filter for steam
- 3 Pressure regulator
- 4 Temperature control pneumatic valve with actuator
- 5 Heat exchanger
- 6 Float steam trap
- 7 Through-flow indicator
- 8 Non-return valve

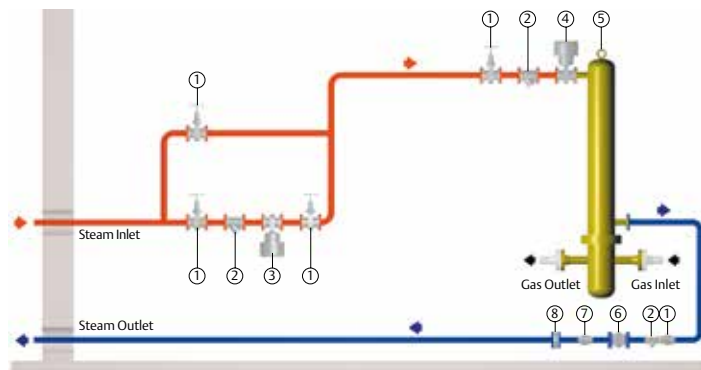

Industrial Regulators

Emerson Process Management Regulator Technologies, Inc.

USA - Headquarters

McKinney, Texas 75070 USA
Tel: +1 800 558 5853
Outside US: +1 972 548 3574

Europe

Bologna 40013, Italy
Tel: +39 051 419 0611

Asia-Pacific

Shanghai 201206, China
Tel: +86 21 2892 9000

Middle East and Africa

Dubai, United Arab Emirates
Tel: +971 4811 8100

Natural Gas Technologies

Emerson Process Management Regulator Technologies, Inc.

USA - Headquarters

McKinney, Texas 75070 USA
Tel: +1 800 558 5853
Outside US: +1 972 548 3574

Europe

Bologna 40013, Italy
Tel: +39 051 419 0611
Chartres 28008, France
Tel: +33 2 37 33 47 00

Asia-Pacific

Singapore 128461, Singapore
Tel: +65 6770 8337

Middle East and Africa

Dubai, United Arab Emirates
Tel: +971 4811 8100

LP-Gas Equipment

Emerson Process Management Regulator Technologies, Inc.

USA - Headquarters

McKinney, Texas 75070 USA
Tel: +1 800 558 5853
Outside US: +1 972 548 3574

TESCOM

Emerson Process Management Tescom Corporation

USA - Headquarters

Elk River, Minnesota 55330-2445 USA
Tel: +1 763 241 3238
+1 800 447 1250

Europe

Selmsdorf 23923, Germany
Tel: +49 38823 31 287

Asia-Pacific

Shanghai 201206, China
Tel: +86 21 2892 9499

For further information visit www.emersonprocess.com/regulators

Our Global Product Brands:



The Emerson logo is a trademark and service mark of Emerson Electric Co. All other marks are the property of their prospective owners. Fisher, Tartarini, Francel, Emerson Process Management and the Emerson Process Management design are marks of the Emerson Process Management group of companies.

The contents of this publication are presented for informational purposes only, and while every effort has been made to ensure their accuracy, they are not to be construed as warranties or guarantees, express or implied, regarding the products or services described herein or their use or applicability. We reserve the right to modify or improve the designs or specifications of such products at any time without notice.

Emerson Process Management does not assume responsibility for the selection, use or maintenance of any product. Responsibility for proper selection, use and maintenance of any Emerson Process Management product remains solely with the purchaser.

O.M.T. Officina Meccanica Tartarini S.R.L., Via P. Fabbri 1, I-40013 Castel Maggiore (Bologna), Italy

R.E.A 184221 BO Cod. Fisc. 00623720372 Part. IVA 00519501209 N° IVA CEE IT 00519501209, Cap. Soc. 1.548 000 Euro i.v. R.I. 00623720372 - M BO 020330

Francel SAS, 3 Avenue Victor Hugo, CS 80125, Chartres 28008, France

SIRET 552 068 637 00057 APE 2651B, N° TVA: FR84552068637, RCS Chartres B 552 068 637, SAS capital 534 400 Euro

D104045X012 - 02/2015 - Rev.00©Emerson Process Management Regulator Technologies, Inc., 2015; All Rights Reserved

