

# Type OL Absorption Type Odorizing Systems

## SUMMARY

Introduction .....	1
PED Categories and Fluid Group .....	1
Characteristics .....	2
Labelling .....	2
Transport and Handling .....	2
Preservation and Storage .....	2
Atex Requirements .....	3
Installation .....	3
Startup and Shutdown .....	5
Maintenance .....	5
Parts List .....	5
Schematic Assemblies .....	6

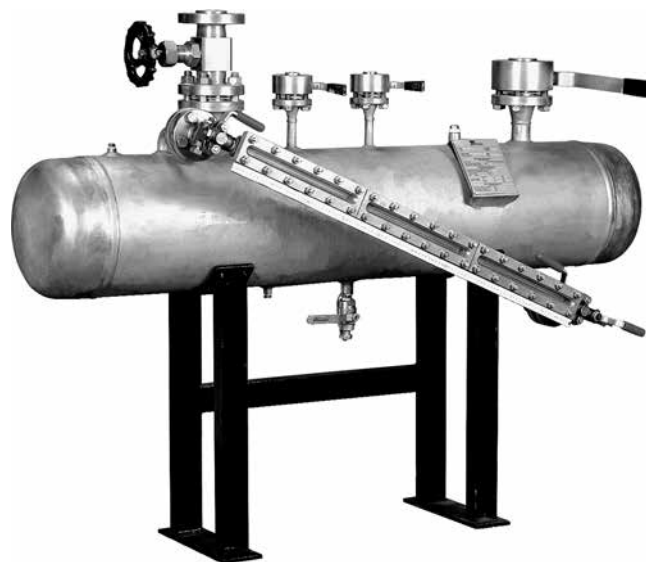

Figure 1. Type OL Odorizing System

This product has been designed to be used with fuel gases of 1st and 2nd family according to EN 437, and with other non aggressive and non fuel gases. For any other gases, other than natural gas, please contact your local sales agent.

## INTRODUCTION

### Scope of Manual

This manual provides instructions for installation, startup, maintenance and spare parts ordering for the OL Series odorizing tanks.

### Product Description

The odorizing systems are employed in small and large-sized stations.

However, they are used as stand-by and emergency systems in all injection-type odorizing installations.

For the proper operation it is necessary to reach a differential pressure.

## PED CATEGORIES AND FLUID GROUP

Table 1. P.E.D. Categories and Fluid Group

TYPE		CATEGORY	FLUID GROUP
OL/___-AP all volumes	Carbon Steel and Stainless Steel	IV	1
OL/25-BP and OL/50-BP		III	
OL/___-BP all other volumes		IV	

# Type OL

## CHARACTERISTICS

### End Connection Styles

The end connections style of the flanged nozzles are:

- PN 6, PN 16 - ANSI 150 (BP version)
- ANSI 600 (AP version)

Other ratings available on request.

Maximum Allowable Pressure (PS) according to nameplate with reference to different ratings.



Table 2. OL Series Characteristics

TYPE	MAXIMUM RATING	MAXIMUM ALLOWABLE PRESSURE, (PS) bar	HYDROSTATIC TEST PRESSURE, (PT) bar
OL/ all volumes	ANSI 600	85 <sup>(1)</sup>	121.5
		90 <sup>(1)</sup>	128.7

1. According to nameplate

### Minimum/Maximum Allowable Temperature (TS)

Maximum TS range up to -20/+ 60°C for all above models is available on request.

The pressure/temperature limits in this Instruction Manual and any applicable standard or code limitation should not be exceeded.

## LABELLING



			
TIPO: TYPE: <b>Note 1</b>		N° FABBR. SERIAL N°	
		DATA: DATE: <b>Note 2</b>	
CARATTERISTICHE DI PROGETTO DESIGN CHARACTERISTICS			
FLUIDO GRUPPO/GROUP FLUID		GAS METANO PIU' LIQUIDO ODORIZZANTE	
(PRESSIONE DI PROGETTO/DESIGN PRESSURE) PS Bar PS MPa		<b>Note 3</b>	
(TEMP. DI PROGETTO/DESIGN TEMPERATURE) TS °C		<b>Note 4</b>	
CARATTERISTICHE COSTRUTTIVE CONSTRUCTIVE CHARACTERISTICS			
RADIOGRAFIA SALDATURE/RADIOGRFY OF THE WELD			
EFFICIENZA SALDATURE/EFFICIENCY OF THE WELD			
CAPACITA'/CAPACITY Lt.			
PESO/WEIGHT KG			
ATTACCHIA FLANGIA FLANGE CONNECTION		IN ENTRATA INLET DN	ANSI <b>Note 5</b> PN <b>Note 5</b>
		IN USCITA OUTLET DN	ANSI <b>Note 5</b> PN <b>Note 5</b>
CARATTERISTICHE DI COLLAUDO TEST CHARACTERISTICS			
(PROVA IDRAULICA/HYDRAULIC TEST)		PT Bar PT MPa	<b>Note 6</b>
(PROVA PNEUMATICA/PNEUMATIC TEST)		PN Bar PN MPa	

Figure 2. Label for OL Series

**Note 1:** See “Characteristics”

**Note 2:** Year of manufacture

**Note 3:** Maximum PS = 90 bar

**Note 4:** Standard Temperature Range: -10°/60°C  
Low Temperature Range: -20°/60°C

**Note 5:** Available with different flange ratings, see “Characteristics”

**Note 6:** PT = 1.5 x PS bar

## TRANSPORT AND HANDLING

The equipment is supplied packaged, transported in horizontal position on transport saddles or cages.

The supports have been designed to withstand the weight of the tank, other stresses should be avoided with proper ligatures.

The equipment can be lifted and placed in working position using a standard lifting systems, please avoid to attach the lifting system to the gas / odorant nozzles.

It's recommended the use of suitable protection to avoid paint damages (in case of painted equipments) and also to avoid any anomalous stress and shock on pressure containing parts.

The transport saddles, if any, are attached to the equipment with straps or steel cables, take care during transport to prevent accidental saddles disconnections.

Established transport and handling procedures shall be followed to avoid any damage to the pressure containing parts.

Particular care must be taken to avoid any possible damage to the pressure accessories installed on the odorant tank (eg the level indicator).

## PRESERVATION AND STORAGE

Stand-alone equipment is delivered with all nozzles blanked and all surfaces completely protected by primer or paint (carbon steel material versions) hence the equipment doesn't need specific precautions for storage, providing to follow the recommendations listed in “Inspection” section on page 4 of this Instruction Manual.

## ATEX REQUIREMENTS



### WARNING

If the provisions of EN 12186 & EN 12279, national regulations, if any, and specific manufacturer recommendations are not put into practice before installation and if purge by inert gas is not carried out before equipment's start-up and shut-down operations, a potential external and internal explosive atmosphere can be present in equipment & gas pressure regulating/measuring stations/installations.

If a presence of foreign material in the pipelines is foreseen and purge by inert gas is not carried out, the following procedure is recommended to avoid any possible external ignition source inside the equipment due to mechanical generated sparks:

- drainage to safe area via drain lines of foreign materials, if any, by inflow of fuel gas with low velocity in the pipe-work (5m/sec)

In any case,

- provisions of Directive 1999/92/EC and 89/655/EC shall be enforced by gas pressure regulating/measuring station/installation's end user
- with a view to preventing and providing protection against explosions, technical and/or organizational measures appropriate to the nature of the operation shall be taken (e.g. : filling/exhausting of fuel gas of internal volume of the isolated part/entire installation with vent lines to safe area - 7.5.2 of EN 12186 & 7.4 of EN 12279 ; monitoring of settings with further exhaust of fuel gas to safe area ; connection of isolated part/entire installation to downstream pipeline; ....)
- provision in 9.3 of EN 12186 & 12279 shall be enforced by pressure regulating/measuring station/installation's end user
- external tightness test shall be carried out after each reassembly at installation site using testing pressure in accordance with national rules
- periodical check/maintenance for surveillance shall be carried out complying with national regulations, if any, and specific manufacturer recommendations.

## INSTALLATION



### WARNING

Only qualified personnel shall install an odorizing tank. Odorizing systems should be installed, operated and maintained in accordance with international and applicable codes and regulations.

Following notes and instructions point out, in particular, the "pressure" risk. Installation, operation and maintenance procedures performed by unqualified personnel may result in unsafe operation.

This condition may result in equipment damage or personal injury. If a leak develops in the system, the escaping gas may accumulate and become a fire or explosion hazard. Immediately call qualified service personnel in case of trouble.

Hazards arising from misuse and misoperating are:

Personal injury, equipment damage, or leakage due to escaping gas or bursting of pressure-containing parts may result if the equipment is installed where its capabilities (PS and TS) can be exceeded or where conditions exceed any ratings of the adjacent piping or piping connections.

To avoid this, install the equipment where:

- Service conditions are within unit capabilities.
- Service conditions are within applicable codes, regulations, or standard.
- The unit is protected from exposure to physical damage and/or corrosive substances.
- Suitable pressure-limiting or pressure-relieving devices have been installed in those instances where supply pressure is capable of exceeding the maximum allowable downstream equipment pressure.

Materials: Odorizing tanks made of carbon steel cannot be used for odorizing liquids containing mercaptanes.

National safety standards and established rules shall be applied in odorizing system installation and operation, concerning, in particular, electrical works, fire, and thunderbolt protection, safety procedures on odorisant handling.

All means for venting have to be provided in the assemblies where the pressure equipment are installed.

Before installation, check shall be done if service conditions are consistent with use limitations.

Where this product is used:

- provide the cathodic protection and electrical isolation to avoid any corrosion
- the gas shall be cleaned by proper filters/separators/scrubbers to avoid any technical & reasonable hazard of erosion or abrasion for pressure-containing parts.

Odorizing tank shall be installed in non-seismic area and hasn't to undergo fire and thunderbolt action.

# Type OL

---

## Inspection

Upon arrival at site the equipment must be inspected for eventual damages occurred during transportation. At least, the following points have to be inspected:

- Integrity of nozzles closure and equipment sealing.
- Status of painted surfaces. If paint is damage any touch-up shall be carried out in accordance with the project coating specification.
- Visual check of critical areas such as nozzles, saddles, clips, ..

Any damage shall be reported to quality control office and eventually to the vendor in order to agree and coordinate any repair work.

The tank have been subject to hydrostatic test at our factory according to Code and Specifications requirements and thoroughly inspected for leakage during the above test.

However, handling during transportation or moving into place may have loose gasketed seals: based upon the above, it is recommended to recheck all bolted connections, if any, prior to startup.

## Cleaning

Thoroughly clean and blow all pipe lines to remove scales and other possible foreign material.

## Piping Up

The piping established practice shall be follow when installing the tank.

## Foundations

Foundation or metallic supports should be suitable to support the equipment and its maximum contents, which may result in stresses caused also by piping connections.

## Levelling

The vessel should be installed to the correct level and vertical line if any within the limits agreed by data sheet or specifications.

## Access

The vessel should be installed with sufficient clearance from associated structures and equipment to provide safe, efficient working by operators and to provide ready access for cleaning, inspection and maintenance.

Support should be so arranged to provide adequate facility for the inspection of every part of the vessel.

## Flanged and Bolted Joints

Accurate vertical and horizontal alignment, with flange faces parallel, is an important precaution to be taken when making up a flanged joint.

A suggested bolt tightening sequence is to process “three o'clock, nine o'clock, twelve o'clock, six o'clock, etc.”

After have complete the above sequence and additional check have to be performed on all bolts.

The same procedure has to be followed in case of maintenance.

## Piping and Connections

To avoid excessive stresses or strains due to piping connections, the following precautions should be taken:

- To avoid stresses arising from nozzle connection, piping should not be forced into alignment when connecting up.
- If the magnitude and direction of external piping forces and moments are known and the nozzles have been designed specifically to these reactions, the above forces and moments are not be exceeded.

## Ventilation

Equipment should have adequate ventilation around them, particularly where vessels are located indoors.

The ventilation requirements should take into account the type of medium which may escape from the equipment.

Special requirements for lethal material should be agreed with the Authority involved.

## Lighting

Where necessary, the illumination level of lighting at the equipment should be sufficient to allow free movement of operating personnel in safety while in operation under normal conditions.

Permanent lighting should provide an illumination level which ensures that portable lights will not be required in the normal operation.

## Drains and Vents

Vent openings are to be located at high points to allow removal of air and non-condensable, particularly on startup and during surveillance in-field hydro test.

Drains are to be located to prevent liquid remaining in contact with any part of equipment.

## Shipping Covers and Plugs

The shipping covers and plugs (if any) should remain in place until equipment is set in position and ready for piping up.

All openings should be inspected for debris or foreign material that could damage the equipment.

## STARTUP AND SHUTDOWN

Equipment operating at high-pressure should be warmed up slowly and uniformly before applying full pressure.

Tank is particularly sensitive to pressure increase very rapidly.

Pressure should be increased in stages of approximately 10% of operating pressure up to the operating value.

In case of leakage or other inconvenience, the procedure should be immediately stopped and the problem investigated and removed before a new startup.

## Gasketed Connections

Before startup and after initial startup, at normal operating pressure and temperature, it is recommended to inspect all gasketed joints for tightness.

## Shutting Down

When possible, reduce slowly the pressure in order to avoid damage.

In no case open the equipment before the pressure is completely released.

## MAINTENANCE

At regular intervals and as frequently as experience indicates, an inspection should be made of the tank condition.

In case of need, specific procedures are prepared by Manufacturer according to national and applicable codes and regulations.

The frequency of inspection/checks and replacements depends upon the severity of service conditions and upon applicable codes and national standards/rules.

If any liquid leakage or gas escaping occurs, safety station procedures shall be applied to shutdown odorizing system and to replace gasketed joints of odorizing tank.

No special spare part is foreseen for odorizing tanks.

## PARTS LIST (See Figure 3)

Key	Description
1	Odorizing Tank
2	Inlet Valve
3	Interception Valve
4	Outlet Valve
5	Needle Valve
6	Ball Valve
7	Plug
8	Level Indicator
9	Level Indicator Interception Valve
10	Nameplate
11	Nameplate Support
12	Tank Support

# Type OL

## SCHEMATIC ASSEMBLIES

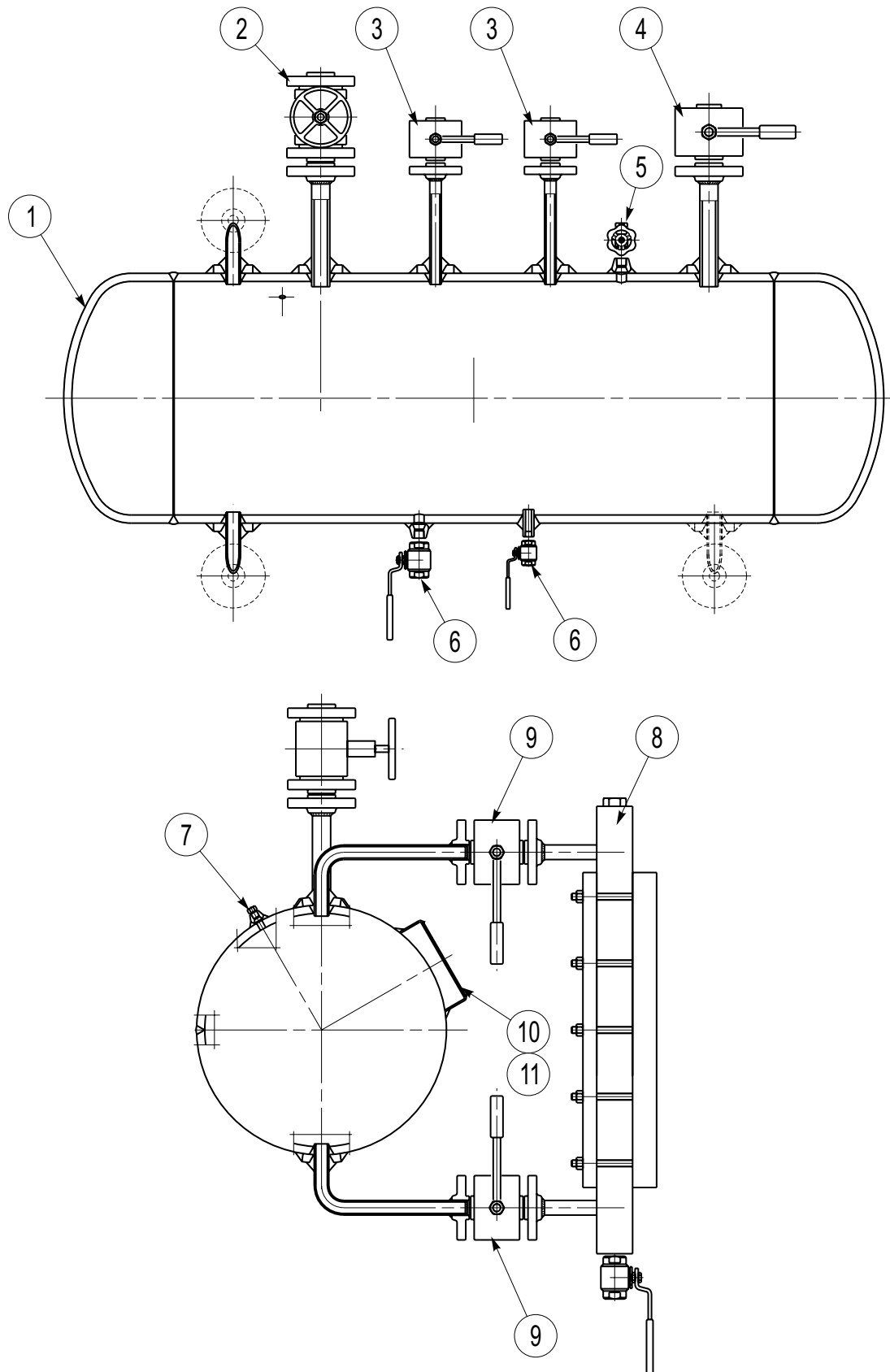
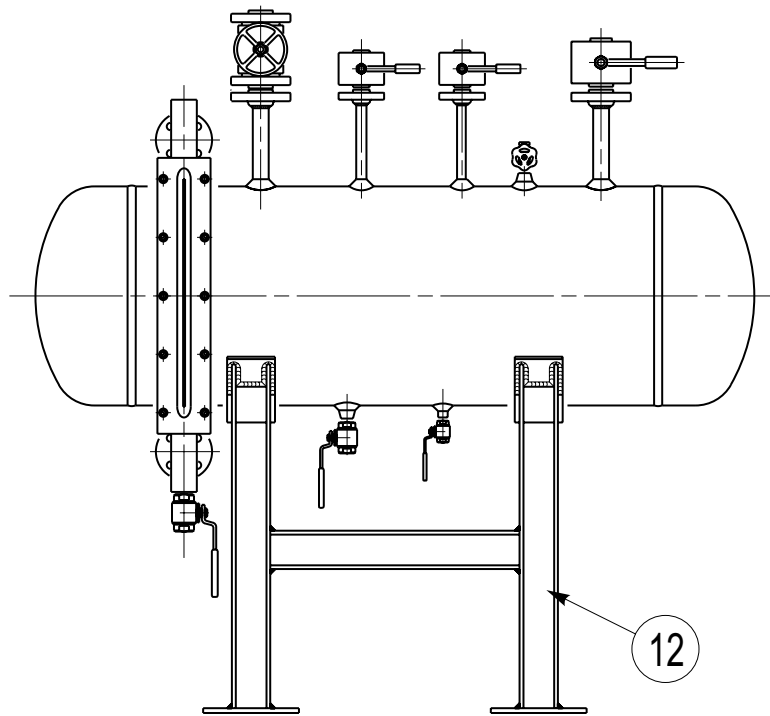
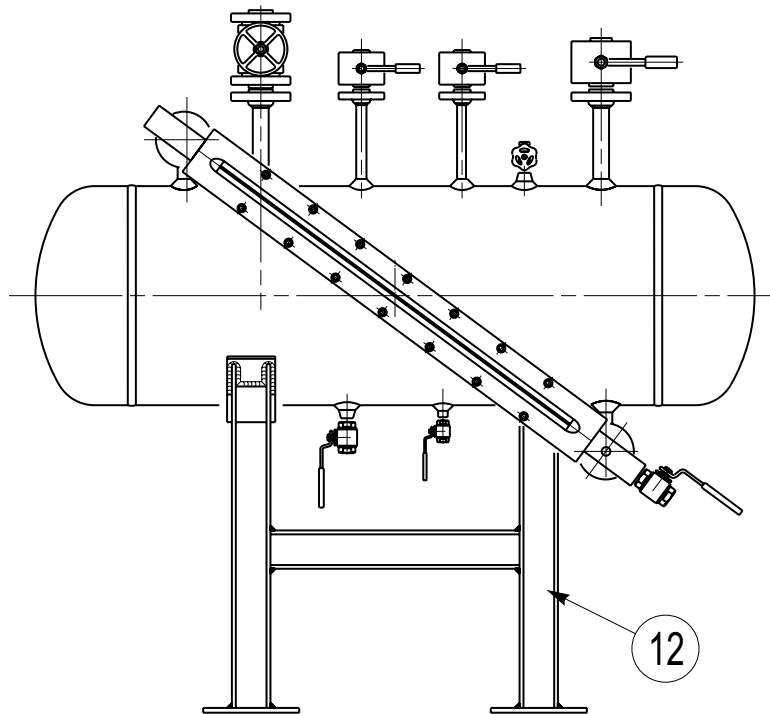

Figure 3. Type OL Odorizing System Assembly



VERTICAL LEVEL INDICATOR



DIAGONAL LEVEL INDICATOR

Figure 3. Type OL Odorizing System Assembly (continued)

# Type OL

---

## Industrial Regulators

### Emerson Process Management Regulator Technologies, Inc.

USA - Headquarters  
McKinney, Texas 75070, USA  
Tel: +1 800 558 5853  
Outside U.S. +1 972 548 3574

Asia-Pacific  
Shanghai 201206, China  
Tel: +86 21 2892 9000

Europe  
Bologna 40013, Italy  
Tel: +39 051 419 0611

Middle East and Africa  
Dubai, United Arab Emirates  
Tel: +971 4811 8100

## Natural Gas Technologies

### Emerson Process Management Regulator Technologies, Inc.

USA - Headquarters  
McKinney, Texas 75070, USA  
Tel: +1 800 558 5853  
Outside U.S. +1 972 548 3574

Asia-Pacific  
Singapore 128461, Singapore  
Tel: +65 6777 8337

Europe  
O.M.T. Tartarini s.r.l. Via P. Fabbri 1,  
I-40013 Castel Maggiore (Bologna), Italy  
Tel: +39 051 419 0611  
Francel SAS, 3 ave Victor Hugo,  
CS 80125 - Chartres 28008, France  
Tel: +33 2 37 33 47 00

Middle East and Africa  
Dubai, United Arab Emirates  
Tel: +971 4811 8100

## TESCOM

### Emerson Process Management Tescom Corporation

USA - Headquarters  
Elk River, Minnesota 55330-2445, USA  
Tels: +1 763 241 3238  
+1 800 447 1250

Asia-Pacific  
Shanghai 201206, China  
Tel: +86 21 2892 9499

Europe  
Selmsdorf 23923, Germany  
Tel: +49 38823 31 287

For further information visit [www.emersonprocess.com/regulators](http://www.emersonprocess.com/regulators)

The Emerson logo is a trademark and service mark of Emerson Electric Co. All other marks are the property of their prospective owners. Tartarini is a mark of O.M.T. Officina Meccanica Tartarini s.r.l., a business of Emerson Process Management.

*The contents of this publication are presented for informational purposes only, and while every effort has been made to ensure their accuracy, they are not to be construed as warranties or guarantees, express or implied, regarding the products or services described herein or their use or applicability. We reserve the right to modify or improve the designs or specifications of such products at any time without notice.*

Emerson Process Management Regulator Technologies, Inc., does not assume responsibility for the selection, use or maintenance of any product. Responsibility for proper selection, use and maintenance of any Emerson Process Management Regulator Technologies, Inc., product remains solely with the purchaser.

O.M.T. Officina Meccanica Tartarini S.R.L., R.E.A 184221 BO Cod. Fisc. 00623720372 Part. IVA 00519501209 N° IVA CEE IT 00519501209,  
Cap. Soc. 1.548 000 Euro i.v. R.I. 00623720372 - M BO 020330

Francel SAS, SIRET 552 068 637 00057 APE 2651B, N° TVA : FR84552068637, RCS Chartres B 552 068 637, SAS capital 534 400 Euro