

A/140 Series Spring Loaded Pressure Regulators

SUMMARY

Introduction	1
PED Categories and Fluid Group	2
Characteristics	2
Labelling	2
Overpressure Protection	3
Transport and Handling	3
Atex Requirements	3
Slam-Shut Controller	3
Dimensions and Weights	4
Operation	5
Installation	6
Startup	6
Adjustment	7
Shutdown	7
Periodical Checks	7
Maintenance	7
Spare Parts	8
Troubleshooting	8
Parts List	9

INTRODUCTION

Scope of Manual

This manual provides instructions for installation, startup, maintenance and spare parts ordering for the A/140 series spring loaded regulators.

Product Description

The A/140 series regulators are spring loaded single seated, with counterbalanced valve disc.

They are usually supplied with safety valve and built in filter and can be also provided with slam-shut controller for minimum pressure, maximum pressure or minimum and maximum downstream pressure.

The regulators of the A/140 series due to their operating specifications are mainly used in those system where sudden capacity variations are required, or else, where the cut-off of the gas distribution is controlled by solenoid valve, such as for the feeding of burners.



Figure 1. Regulator Type A/149

This product has been designed to be used with fuel gases of 1st and 2nd family according to EN 437, and with other non aggressive and non fuel gases. For any other gases, other than natural gas, please contact your local sales agent.

The following versions are available:

A/142 - A/142-AP: Regulator

A/149 - A/149-AP: Regulator with slam-shut

Versions without relief valve available on request

Tightness cover versions available on request (e.g. A/149-D).

The standard gas pressure devices (regulators and safety shut-off devices) are those used in the assemblies dealt with into EN 12186 and EN 12279 and their use has to be under the provisions into ENs 12186 & 12279.

Fail open stand-alone regulators cannot be used as a safety accessory according PED 2014/68/UE to protect downstream pressure equipment.

In the pressure regulators (with or without built-in safety shut-off devices) manufactured by Emerson shall be used additional pressure accessories (e.g. pilots or filters) manufactured and labeled by Emerson.

Emerson will be not responsible for any possible inefficiency due to installation of not own production additional pressure accessories (e.g. pilots or filters).

When pressure containing parts of possible built-in safety shut-off device (SSD) valve and pilot have different maximum allowable pressures, the SSD is differential strength type.

Type A/140

PED CATEGORIES AND FLUID GROUP

According to EN 14382, only in integral strength type and Class A configuration (when both over and under pressure protections are set up), the possible built-in safety shut-off device can be classified like a safety accessory according to PED.

The minimum PS between SSD valve and pilot shall be the PS of the safety accessory to comply the provisions of EN 14382 about integral strength type.

Downstream equipments, protected by possible built-in safety shut-off device (in its Class A and integral strength configuration) of this product, shall have technical features such as to be category per table below according Directive PED 2014/68/UE.

Table 1. PED Category for A/140 Series Regulators

PRODUCT SIZE	CATEGORY	FLUID GROUP
DN 50 WITHOUT SLAM-SHUT	I	1
DN 50 WITH SLAM-SHUT	IV	

Possible built-in pressure accessories (e.g. pilots OS66/) conform to Pressure Equipment Directive PED 2014/68/UE Article 4 section 3 and were designed and manufactured in accordance with sound engineering practice (SEP).

Per Article 4 section 3, these "SEP" products must not bear the CE marking.

CHARACTERISTICS

Body Sizes and End Connection Styles

DN 50 PN 16 UNI/DIN flanged



WARNING

The pressure/temperature limits indicated in this instruction manual or any applicable standard or code limitation should not be exceeded.

Maximum Operating Inlet Pressure

A/142 • A/149: 6 bar

A/142-AP • A/149-AP: 6 bar

At average ambient temperature.

Outlet Set Pressure Ranges

A/142 • A/149: 10 to 75 mbar

A/142-AP • A/149-AP: 75 to 500 mbar

(Range 300 to 500 mbar with QL option)

Minimum/Maximum Allowable Temperature (TS)

See label

Functional Features

Accuracy Class AC : up to $\pm 5\%$

Lock-up Pressure Class SG : up to + 10%

Slam-Shut Controller

Accuracy Class AG : $\pm 5\%$

Response Time t_a : ≤ 1 second

Orifice

30 mm

Temperature

Standard Version: Working -10° to 60°C

Low Temperature Version: Working -20° to 60°C

Materials

Servomotor body: Aluminium

Cover: Aluminium

Body: Ductile iron (steel available on request)

Sleeve: Brass

Seat: Brass

Diaphragm: Fabric Nitrile (NBR)

Gaskets: Nitrile (NBR) rubber

LABELLING

TARTARIN BOLOGNA ITALY		CE	Modified body xxxx	APPARECCHIO TIPO / DEVICE TYPE
				Note 1
MATRICOLA / ANNO SERIAL Nr. / YEAR	/ Note 2		DN1	
REAZIONE FAIL SAFE MODE	FAIL OPEN <input checked="" type="checkbox"/>	FAIL CLOSE <input type="checkbox"/>	DN2	
NORME ARMONIZ. HARMONIZED STD.	EN		Wds	bar
CLASSE DI PERDITA LEAKAGE CLASS		TIPO TYPE	Wdso	bar
CLASSE FUNZIONALE FUNCTIONAL CLASS		Cg	Wdsu	bar
FLUIDO GRUPPO FLUID GROUP	1	pmax	bar	DN seat
TS	Note 3	$^\circ\text{C}$	PS	bar
			PSD	Bar PT= 1.5 x PS bar

Figure 2. Label for A/140 Series Regulators

Note 1: See "Characteristics"

Note 2: Year of manufacture

Note 3: Class 1: $-10^\circ/60^\circ\text{C}$
Class 2: $-20^\circ/60^\circ\text{C}$

OVERPRESSURE PROTECTION

The recommended maximum allowable pressures are stamped on the regulator nameplate.

If actual version hasn't a built-in safety shut-off device, some type of overpressure protection is needed if the actual outlet pressure exceeds the actual maximum operating outlet pressure rating.

Overpressure protection should also be provided if the regulator inlet pressure is greater than the maximum operating inlet pressure. Downstream side pressure after possible built-in SSD's intervention shall stay within the actual maximum operating set-up range to avoid anomalous back pressures that can damage the SSD's pilot.

Downstream overpressure protection shall be also provided if the SSD outlet pressure can be greater than the PS of the SSD pilot (differential strength type).

Regulator operation below the maximum pressure limitations does not preclude the possibility of damage from external sources or debris in the line.

The regulator should be inspected for damage after any overpressure condition.

TRANSPORT AND HANDLING

Established transport and handling procedures shall be followed to avoid any damage on the pressure containing parts by shocks or anomalous stresses.

Built-up sensing lines and pressure accessories shall to be protected by shocks or anomalous stresses.

ATEX REQUIREMENTS

If the provisions of EN 12186 & EN 12279, national regulations, if any, and specific manufacturer recommendations are not put into practice before installation and if purge by inert gas is not carried out before equipment's start-up and shut-down operations, a potential external and internal explosive atmosphere can be present in equipment & gas pressure regulating/measuring stations/installations.

If a presence of foreign material in the pipelines is foreseen and purge by inert gas is not carried out, the following procedure is recommended to avoid any possible external ignition source inside the equipment due to mechanical generated sparks:

- drainage to safe area via drain lines of foreign materials, if any, by inflow of fuel gas with low velocity in the pipe-work (5m/sec)

In any case,

- provisions of Directive 1999/92/EC and 89/655/EC shall be enforced by gas pressure regulating/measuring station/ installation's end user
- with a view to preventing and providing protection against explosions, technical and/or organizational measures appropriate to the nature of the operation shall be taken

(e.g.: filling/exhausting of fuel gas of internal volume of the isolated part/entire installation with vent lines to safe area - 8.6.2 of EN 12186 & 7.4 of EN 12279, monitoring of settings with further exhaust of fuel gas to safe area, connection of isolated part/entire installation to downstream pipeline;)

- provision in 10.2.3 of EN 12186 and 9.3 12279 shall be enforced by pressure regulating/measuring station/ installation's end user
- external tightness test shall be carried out after each reassembly at installation site using testing pressure in accordance with national rules
- in case of selfop regulators diaphragm's incidental failure the amount of maximum flow to be vented can be calculated using the universal gas sizing equation, assuming inlet pressure = regulator's set-point, outlet pressure = atmospheric pressure and venting hole DN on the regulator's upper cover = 16 mm (Cg = 280).
- periodical check/maintenance for surveillance shall be carried out complying with national regulations, if any, and specific manufacturer recommendations.

SLAM-SHUT CONTROLLER

The following controllers are used with A/140 series regulator with built-in slam-shut:

- OS/66 Series spring loaded controllers



Figure 3. OS/66 Slam-Shut Controller

Table 2. OS/66 Characteristics

MODEL	BODY RESISTANCE bar	OVERPRESSURE SET RANGE W_{oo} bar		UNDERPRESSURE SET RANGE W_{uu} bar	
		Min.	Max.	Min.	Max.
OS/66	6	0.022	0.6	0.007	0.45
OS/66-AP	6	0.2	5	0.1	2.5

Materials

Body: Aluminium

Cover: Steel

Diaphragm: NBR rubber

For further informations please see the Instruction Manual D103657X012.

Type A/140

DIMENSIONS AND WEIGHTS

A/142 • A/142-AP

A/149 • A/149-AP

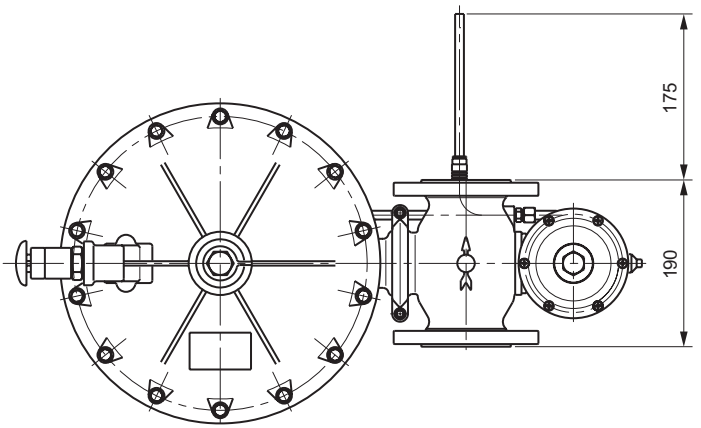
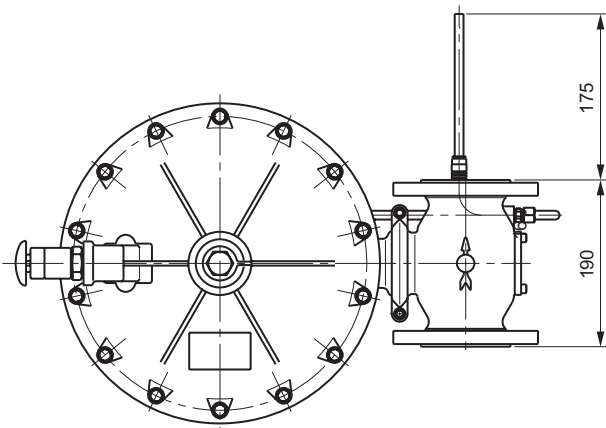
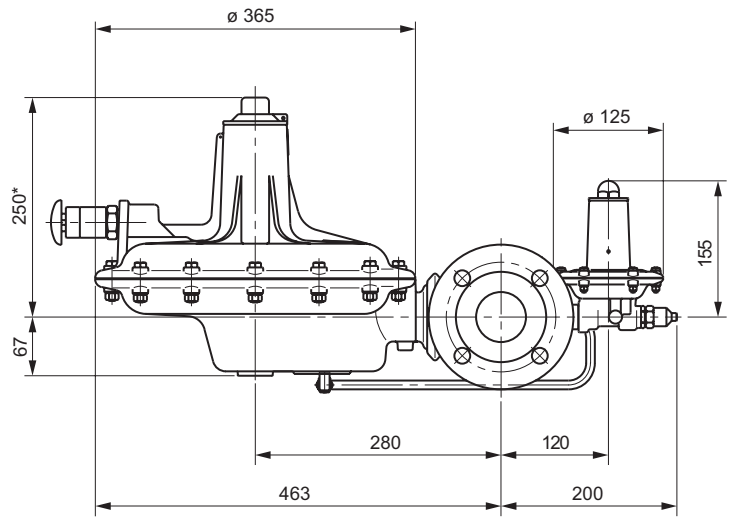
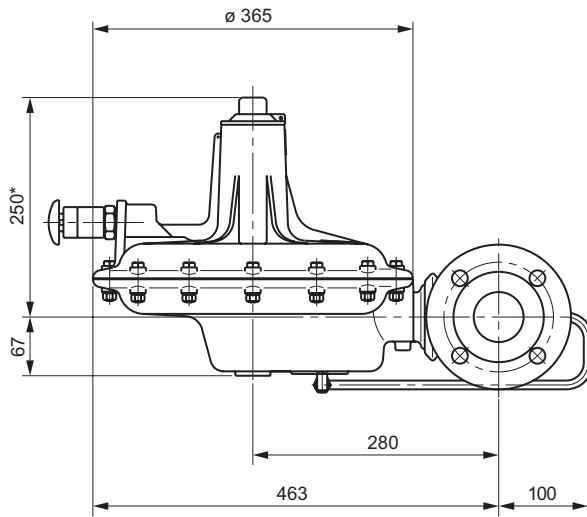

Note: The regulator can be installed with vertical or horizontal orientation of the actuator.

* In high pressure versions (AP), this dimension must be increased by 100 mm.

Figure 4. A/140 Series Dimensions (mm)

Weights:

A/142 • A/142-AP: 19 kg

A/149 • A/149-AP: 20 kg

OPERATION

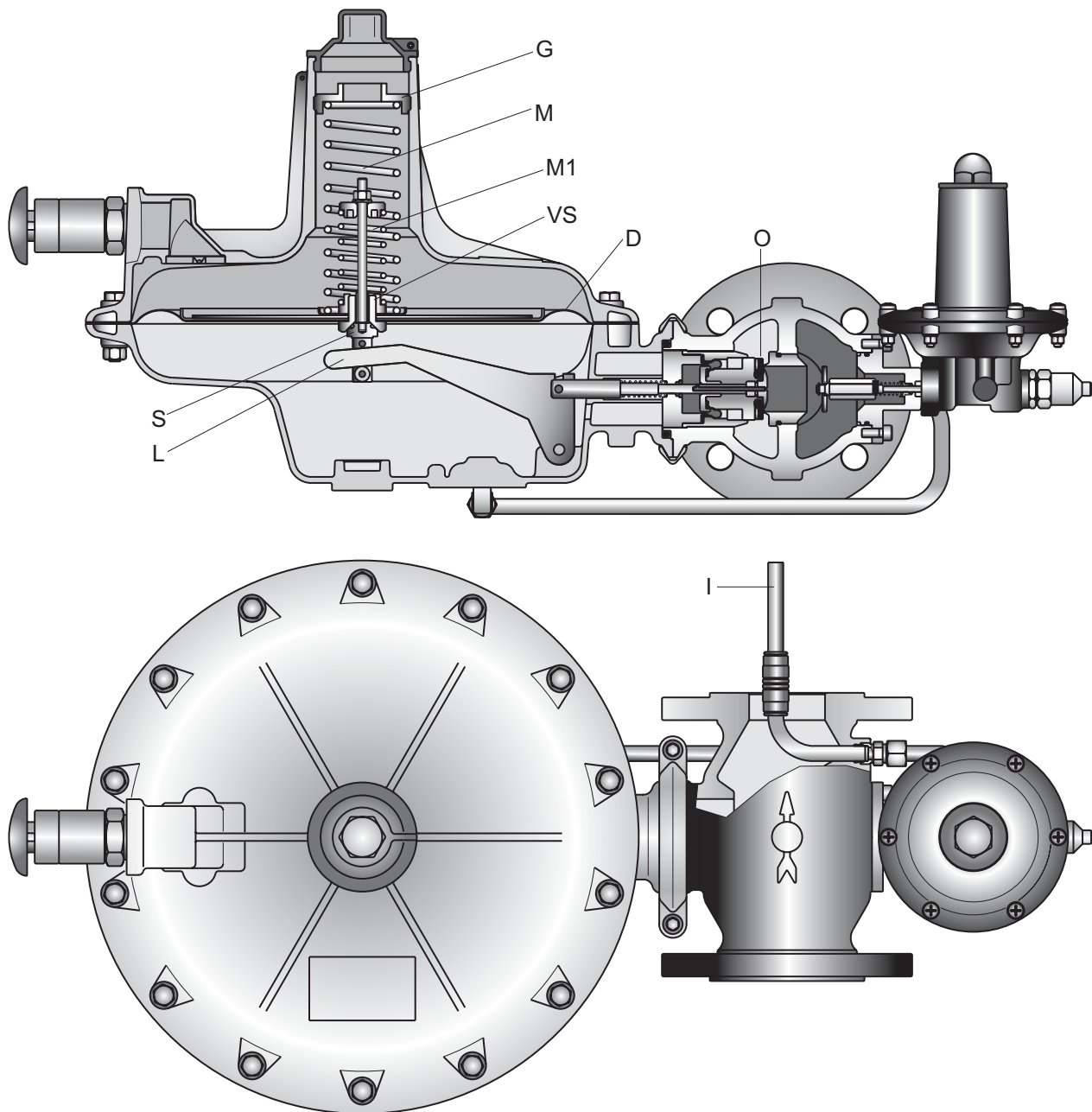

Figure 5. A/140 Series Operational Schematic

The movements of the diaphragm (D) are transmitted to the valve disc (O) by the stem (S) and the lever (L). The downstream pressure through the pulse pipe (I) exerts a force under diaphragm (D) and this force is counteracted by the adjusting spring (M).

The gas pressure on the diaphragm tends to close the valve disc; the antagonist action of the adjustment spring tends to open it. Under normal conditions the balance between these antagonist actions positions the valve disc in such a way as to ensure a constant pressure and therefore the downstream capacity.

Upon any capacity variation tending to cause an increase or decrease of pressure in relation to the pre-set pressure, the moving unit reacts and finds a new balance, so re-establishing the pressure.

Upon request the regulator is also provided with safety valve (VS) incorporated in the diaphragm (D); the adjustment at the pre-set value is performed by means of spring (M1).

For the OS/66 slam-shut controller operation please see the D103657X012 instruction manual.

INSTALLATION

- Ensure that the data found on the regulator plate are compatible with usage requirements.
- Ensure that the regulator is mounted in accordance with the direction of flow indicated by the arrow.



WARNING

Installation shall be in accordance with national standard for material use limitations in gas pressure reducing stations. Only qualified personnel should install or service a regulator. Regulators should be installed, operated, and maintained in accordance with international and applicable codes and regulations, and O.M.T. Tartarini instructions. If the regulator vents fluid or a leak develops in the system, it indicates that service is required. Failure to take the regulator out of service immediately may create a hazardous condition.

Personal injury, equipment damage, or leakage due to escaping fluid or bursting of pressure-containing parts may result if this regulator is over pressured or is installed where service conditions could exceed the limits given in the Specifications section, or where conditions exceed any ratings of the adjacent piping or piping connections. To avoid such injury or damage, provide pressure-relieving or pressure-limiting devices (as required by the appropriate code, regulation, or standard) to prevent service conditions from exceeding limits.

Additionally, physical damage to the regulator could result in personal injury and property damage due to escaping fluid. To avoid such injury and damage, install the regulator in a safe location. Before installation, check shall be done if service conditions are consistent with use limitations and if pilot set-up of possible built-in safety shut-off device are in accordance with service conditions of protected equipment.

All means for venting have to be provided in the assemblies where the pressure equipment are installed (ENs 12186 & 12279).

All means for draining have to be provided in the equipment installed before regulators & shut-off devices (ENs 12186 & 12279).

Further the ENs 12186 & 12279, where this product is used:

- provide the cathodic protection and electrical isolation to avoid any corrosion and
- in accordance with clause 7.3/7.2 of afore-said standards, the gas shall be cleaned by proper filters/separators/scrubbers to avoid any technical & reasonable hazard of erosion or abrasion for pressure containing parts.

Pressure equipment in subject shall be installed in non-seismic area and hasn't to undergo fire and thunderbolt action.

Clean out all pipelines before installation of the regulator and check to be sure the regulator has not been damaged or has collected foreign material during shipping.

For threaded bodies, apply pipe compound to the male pipe threads.

For flanged bodies, use suitable line gaskets and approved piping and bolting practices. Install the regulator in any position desired, unless otherwise specified, but be sure flow through the body is in the direction indicated by the arrow on the body.

Installation must be done avoiding anomalous stresses on the body and using suitable joint means according equipment dimensions and service conditions.

For a correct and safe use of the connections check also Instruction Manual and Bulletin before installation.

User has to check and carry out any protection suitable for assembly's specific environment.

Note: It is important that the regulator be installed so that the vent hole in the spring case is unobstructed at all times.

For outdoor installations, the regulator should be located away from vehicular traffic and positioned so that water, ice, and other foreign materials cannot enter the spring case through the vent.

Avoid placing the regulator beneath eaves or downspouts, and be sure it is above the probable snow level.

STARTUP

The regulator and/or slam-shut controller is factory set at approximately the midpoint of the spring range or the pressure requested, so an initial adjustment may be required to give the desired results.

With proper installation completed and relief valves properly adjusted, slowly open the upstream and downstream line valves.

- a. Slightly and very slowly open the outlet cut-off valve.
- b. In case of models fitted with slam-shut valve, relatch the valve by first loosening cap (C) and then screwing it onto the stem, after which pull cap outwards until a click is heard, indicating that balls are duly engaged.
- c. Slightly and very slowly open the inlet cut-off valve.
- d. Wait for outlet pressure to stabilize.
- e. Finally, slowly open inlet and outlet cut-off valves fully.

ADJUSTMENT

To change the outlet pressure, remove the closing cap (key 1) and turn the adjusting nut (key 2) clockwise to increase outlet pressure or counter clockwise to decrease pressure.

Monitor the outlet pressure with a test gauge during the adjustment.

Remount the closing cap (key 1).

SHUTDOWN



WARNING

To avoid personal injury resulting from sudden release of pressure, isolate the regulator from all pressure before attempting disassembly and release trapped pressure from the equipment and pressure line.

In case of disassembly of main pressure retaining parts for checks and maintenance procedures, external and internal tightness tests have to be done according applicable codes.

PERIODICAL CHECKS



CAUTION

It is recommended that checks be made periodically on the efficiency of the regulator and pilots.

Regulator Checking

Slowly close the outlet cut-off valve and check pressure in the length of pipe between the regulator and the valve.

If the system is functioning properly, an increase in outlet pressure will be noticed due to lock-up pressure, after which pressure will stabilize.

If, on the contrary, outlet pressure continues increasing, the system is not functioning properly due to improper valve disc tightness. In this case, close the valve located upstream of regulator and carry out maintenance procedures.

Relief Valve Checking (if installed)

Close the valve located downstream of regulator. Next, connect a manual pump or other similar device to a previously fitted impulse connection between the regulator and the valve and raise the pressure until relief valve is activated, i.e. until gas is released from vent.

Slam-Shut Controller Checking (if installed)

See the Instruction Manual D103657X012.

MAINTENANCE (SEE FIGURE 6)



WARNING

All maintenance procedures must be carried out only by qualified personnel. If necessary, contact our technical support representatives or our authorized dealers.

The regulator and its pressure accessories are subject to normal wear and must be inspected periodically and replaced if necessary.

The frequency of inspection/checks and replacement depends upon the severity of service conditions and according to applicable National or Industry codes, standards and regulations/recommendations.

In accordance with applicable National or Industry codes, standards and regulations/recommendations, all hazards covered by specific tests after final assembling before applying the CE marking, shall be covered also after every subsequent reassembly at installation site, in order to ensure that the equipment will be safe throughout its intended life.

Before proceeding with any maintenance work, shutoff the gas upstream and downstream from the regulator, also ensure that there is no gas under pressure inside the body by loosening the upstream and downstream connections.

Upon completion, check for leaks using suds.

General Maintenance

- Remove screws (key 54) and clamp (key 55) in order to take off diaphragm case.
- Remove screw (key 30) and check pad unit (key 22).
- Unscrew stem (key 19) and strip all parts down. Check diaphragm (key 21). Carefully clean all parts with petrol and replace those which are found to be worn out.
- By means of the appropriate tool, unscrew seat (key 28) and check O-ring (key 23). Replace seat if worn or scored.
- Remove cap (key 1), adjusting nut (key 2) and spring (key 3), taking care to mark the exact position of the adjusting nut for remounting.
- Remove screws (key 42) and take off cover (key 14).
- Remove the diaphragm unit from the servomotor body.
- Dismount the diaphragm unit. In the models fitted with relief valve unscrew the nut (key 5), remove the spring (key 8) (take care to mark the height of the preloaded spring in order to reassemble it in its original position, thus ensuring proper setting of the relief valve) and unscrew the adjusting nut (key 11).

Type A/140

In other types unscrew the nut (key 5) and the adjusting nut (key 11).

- i. Check diaphragm (key 16), gasket (key 41), the relief valve seat (key 13) and O-Ring (key 48). Replace the worn parts.
- j. Check O-Ring (key 18 and 27).

Relatching Unit Maintenance (if installed)

- a. Trigger actuator and remove impulse line (A).
- b. Loosen dowels (G) and remove OS/66 actuator.
- c. Remove screws (key 24), remove plug (key 26) from the body and check shaft (key 67); if worn or damaged, unscrew the slam-shut pad unit (key 72), strip all parts down and replace the shaft.
- d. Carefully clean and check all components, replacing those worn out.
- e. Lubricate all parts and reassemble by reversing the above steps.

See the Instruction Manual D103657X012 for the slam-shut controller maintenance.

Reassembling

Lubricate all seals with "MOLYKOTE 55 M" and be very careful not to damage them when reassembling.

Reassemble by reversing the above steps.

As you proceed, make sure that parts move freely and without friction.

In addition:

- a. Diaphragm unit (key 16), is properly reassembled by lubricating it with some grease and by carefully fitting it into the servomotor body (key 36).
- b. All screws are duly tightened in order to ensure proper sealing.
- c. If installed check the correct relatching of the slam-shut controller (see Startup item b).
- d. Check for leaks using suds.

SPARE PARTS

Spare parts storage shall be done by proper procedures according to national standard/rules to avoid over aging or any damage.

TROUBLESHOOTING

Table 3. General Troubleshooting for A/140 Series

SYMPTOMS	CAUSE	ACTIONS
The regulator does not open	Lack of incoming gas	Check the station feeding
	The slam-shut controller has not been reset	Manually reset the slam-shut controller
Drop in pressure downstream from the regulator	Insufficient upstream pressure	Check the station feeding
	Flow requirements higher than the flow that the regulator can supply	Check the regulator sizing
	Filter upstream is obstructed	Clean or replace it
Increase in pressure downstream from the regulator or safety devices being activated (relief valve or slam-shut valve)	Tight shutoff gaskets are worn	To be replaced
	Deposits of grime on the tight shutoff pad are obstructing proper positioning of the shutter	Clean or replace it
	Diaphragm damaged	To be replaced
Slam-shut device does not execute tight shutoff procedure	O-ring and/or slam-shut pad worn	To be replaced
	Slam-shut seat damaged	To be replaced

PARTS LIST

Key	Description
1	Closing cap
2	Adjusting nut
3	Spring
4	Plate
5	Nut
6	Washer
7	Spring holder
8	Spring
9	Stem
10	Relief valve pipe
11	Adjusting nut
12	Spring guide plate
13	Relief valve seat
14	Cover
15	Plate
16*	Diaphragm
17	Forked stem
18*	O-ring
19	Counterbalancing stem
20	Plate
21*	Diaphragm
22*	Pad unit
23*	O-ring
24	Screw
25	Washer
26	Plug
27*	O-ring
28	Seat
29	Body
30	Screw
31	Pad holder
32	Guide bush
33*	Stem bush unit
34	Spring
36	Servomotor body
37	Lever
38	Connection
40	Washer
41*	Gasket
42	Screw
47	Vibrations dumper
48	Relief valve stem unit
49	Plate
50*	O-ring
51	Elastic pin
52	Screw
53	Pin
54	Screw
55	Clamp
56	Washer
57	Nut
58	Pipe
59	Connection
60	Pipe
61	Connection
62	Pipe
63	Ball
64	Spring holder
65	Spacer
66*	O-ring
67	Shaft
68*	O-ring
69	Slam-shut spring holder
70	Slam-shut pad holder
71	Elastic ring
72*	Slam-shut pad unit
73	Spring
75	Plug
76	Gasket
77	Washer
78*	O-ring
79*	O-ring
80	Extension
81	Adjusting nut
82	Spring holder
83	Connection
84*	O-ring
85	Disc
86	Screw
87	Plate
200	Proximity
201	Disc
202	Nut
203	Bracket

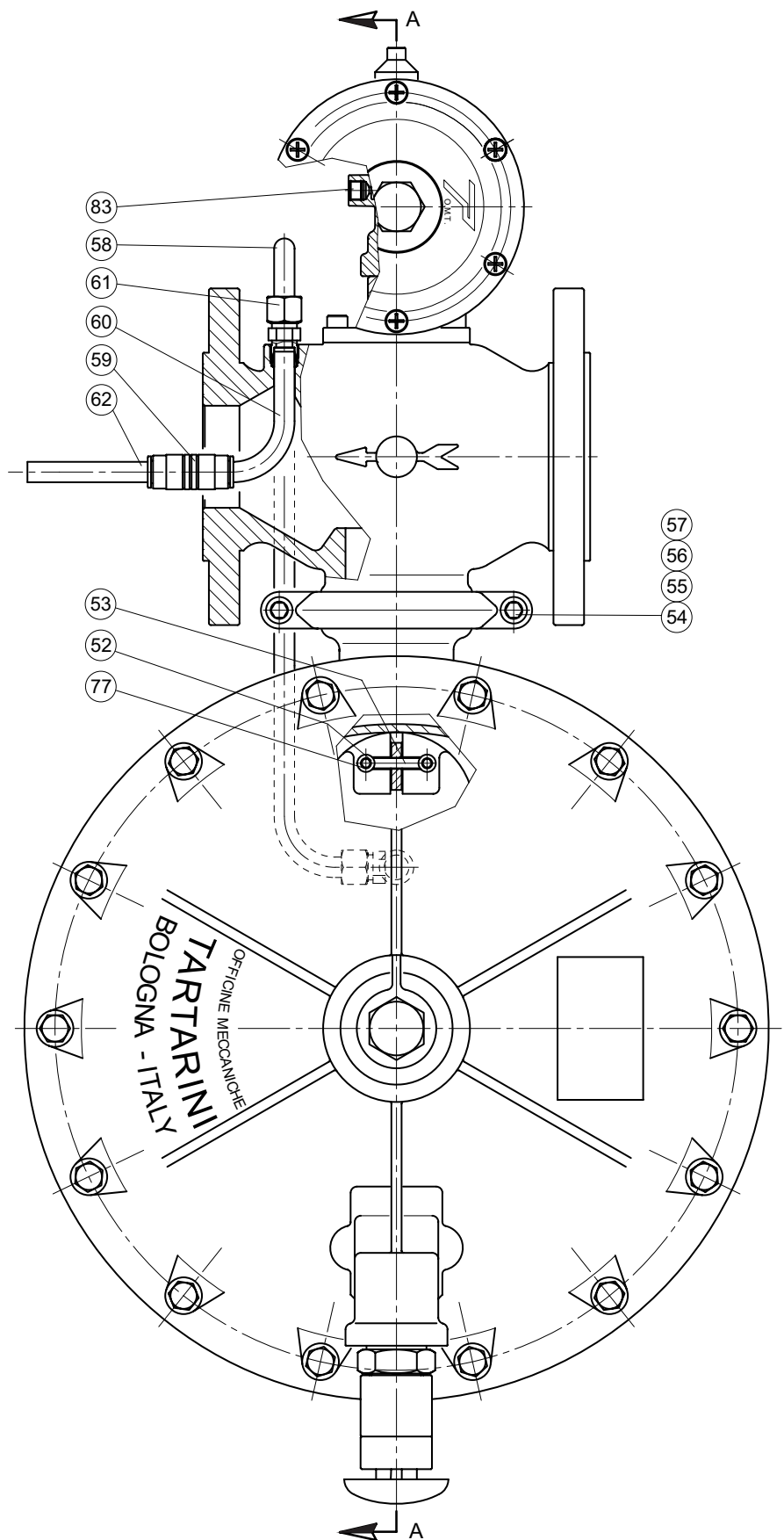
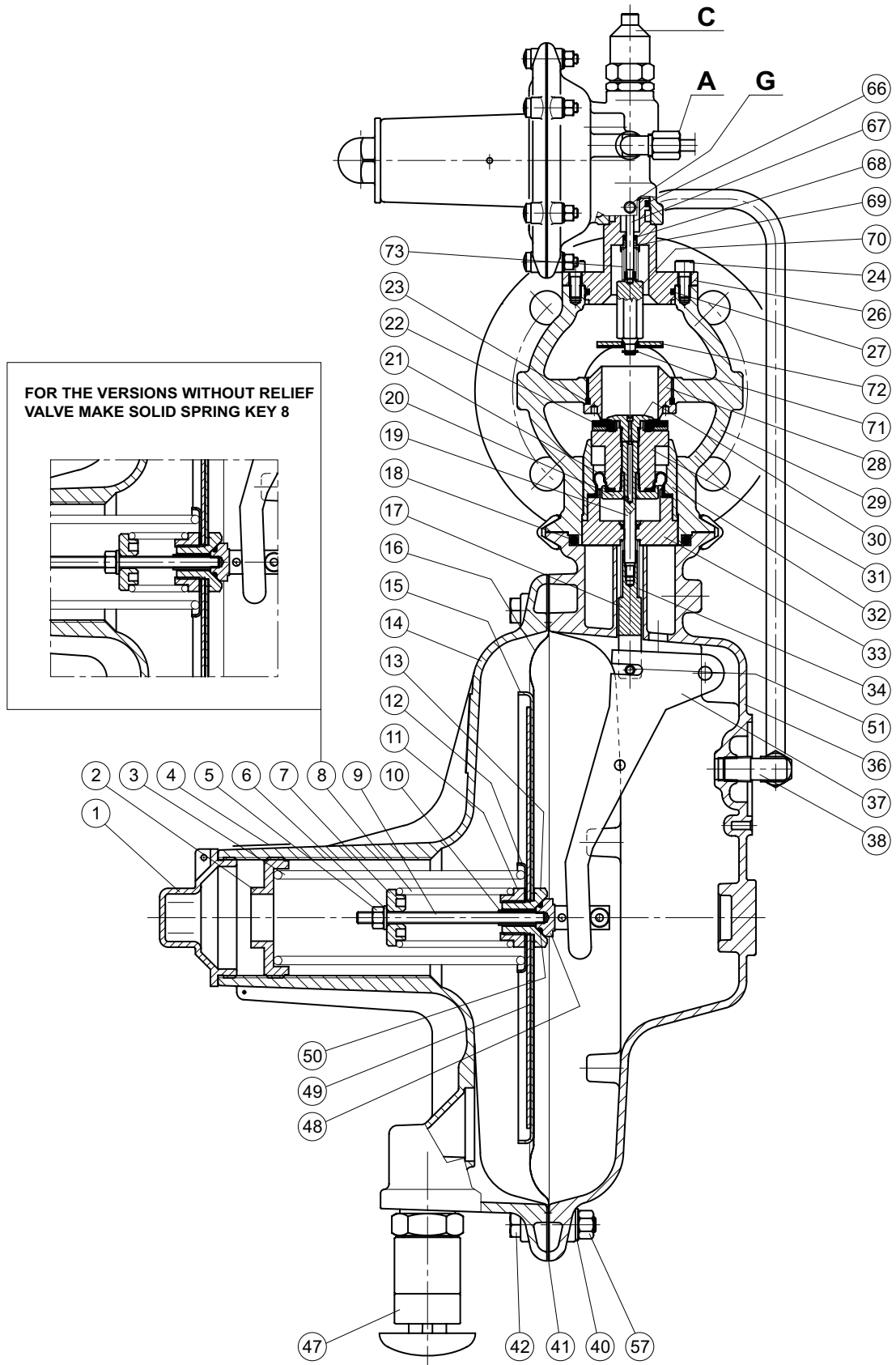

Figure 6. A/140 Series Regulator

Rubber parts marked with (*) are supplied in the "spare parts kit", recommended as stock. To order the kit it is necessary to communicate to us the type of the regulator and its serial number.

Type A/140

SEZ. A-A



LM/1853

Figure 6. A/140 Series Regulator (continued)

TIGHTNESS COVER VERSION

BP DETAIL

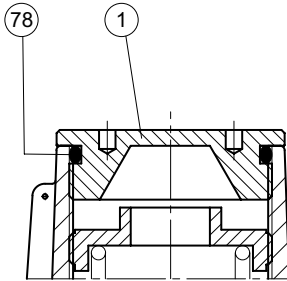

AP DETAIL

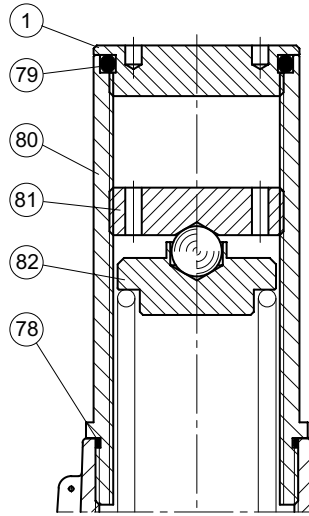

AE/149 DETAILS

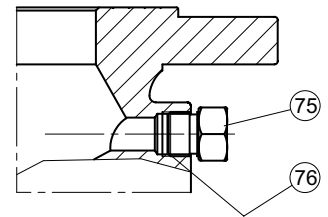
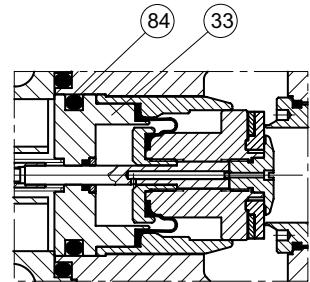

AP VERSION DETAIL FOR OUTLET PRESSURE 300 TO 500 mbar (QL OPTION)

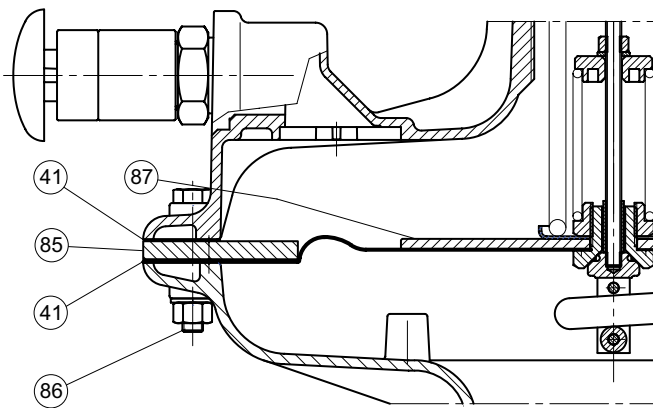

VERSION WITHOUT SLAM-SHUT

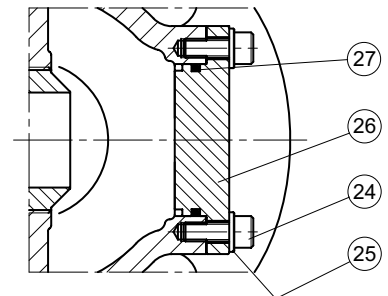

A/149 WITH PROXIMITY VERSION

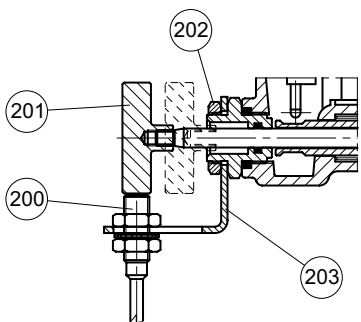

AP VERSION

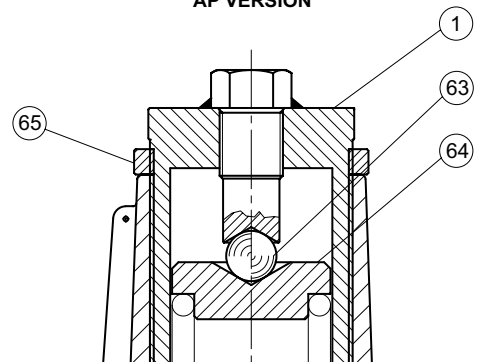

Figure 6. A/140 Series Regulator (continued)

Type A/140

✉ Webadmin.Regulators@emerson.com

🔍 Tartarini-NaturalGas.com

📘 Facebook.com/EmersonAutomationSolutions

🌐 LinkedIn.com/company/emerson-automation-solutions

🐦 Twitter.com/emr_automation

Emerson Automation Solutions

Americas

McKinney, Texas 75070 USA
T +1 800 558 5853
+1 972 548 3574

Europe

Bologna 40013, Italy
T +39 051 419 0611

Asia Pacific

Singapore 128461, Singapore
T +65 6770 8337

Middle East and Africa

Dubai, United Arab Emirates
T +971 4 811 8100

*O.M.T. Officina Meccanica Tartarini S.R.L., Via P. Fabbri 1, I-40013 Castel Maggiore (Bologna), Italy
R.E.A 184221 BO Cod. Fisc. 00623720372 Part. IVA 00519501209 N° IVA CEE IT 00519501209,
Cap. Soc. 1.548 000 Euro i.v. R.I. 00623720372 - M BO 020330*

*Francel SAS, 3 Avenue Victor Hugo, CS 80125, Chartres 28008, France
SIRET 552 068 637 00057 APE 2651B, N° TVA : FR84552068637, RCS Chartres B 552 068 637,
SAS capital 534 400 Euro*

D103662X012 © 2017 Emerson Process Management Regulator Technologies, Inc. All rights reserved. 08/17.

The Emerson logo is a trademark and service mark of Emerson Electric Co. All other marks are the property of their prospective owners. Tartarini™ is a mark of O.M.T. Officina Meccanica Tartarini s.r.l., a business of Emerson Automation Solutions.

The contents of this publication are presented for information purposes only, and while effort has been made to ensure their accuracy, they are not to be construed as warranties or guarantees, express or implied, regarding the products or services described herein or their use or applicability. All sales are governed by our terms and conditions, which are available on request. We reserve the right to modify or improve the designs or specifications of our products at any time without notice.

Emerson Process Management Regulator Technologies, Inc does not assume responsibility for the selection, use or maintenance of any product. Responsibility for proper selection, use and maintenance of any Emerson Process Management Regulator Technologies, Inc. product remains solely with the purchaser.

