

# PRESSURE REGULATORS

Type FL

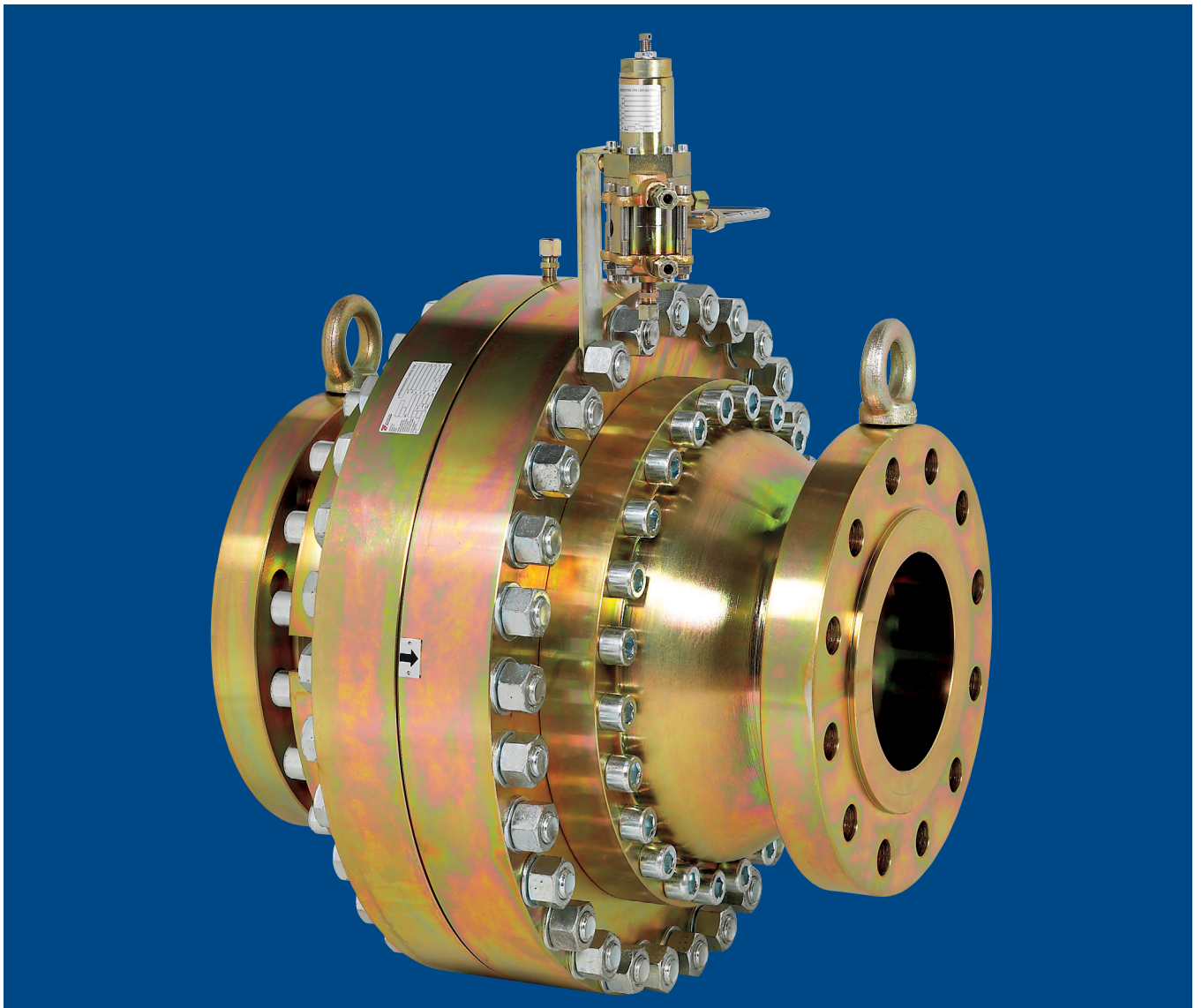

# FL Regulators

---

## Pressure Regulators

This series of axial flow appliances was designed to meet a wide range of applications. Worldwide customer appreciation is based on the reliability and versatility of this product.

The main features are as follows:

- *Greater flow rates than “top entry” regulators*
- *Counterbalanced shutter*
- *Fabric reinforced diaphragm*
- *Low number of parts*
- *Modularity design*

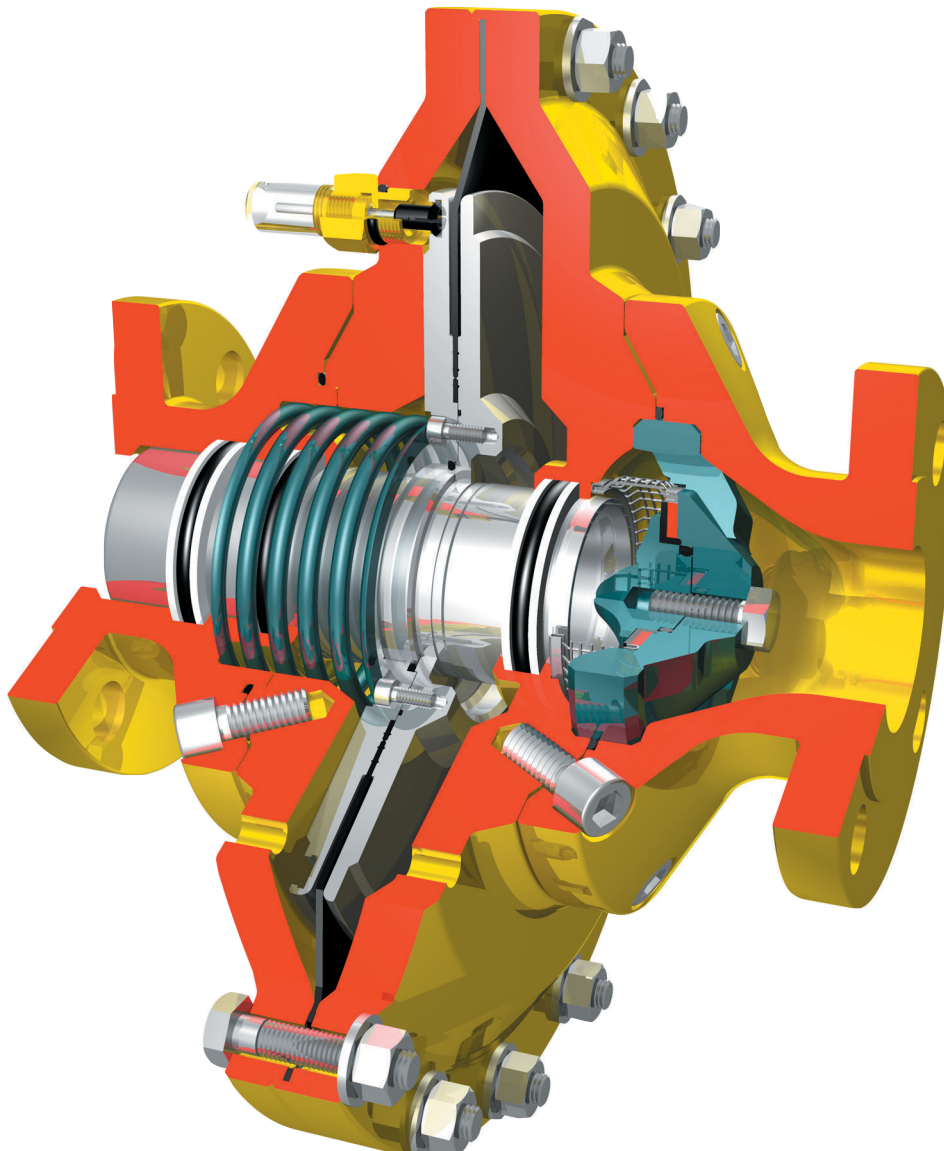

## Configurations



FL Regulator



MFL Regulator + Monitor

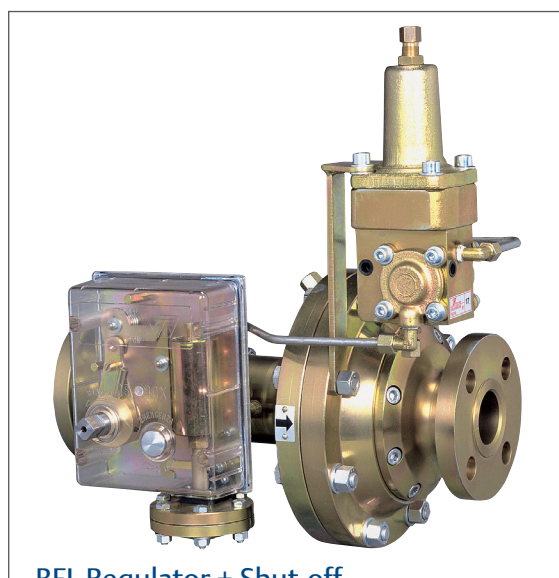

BFL Regulator + Shut-off

Configurations	ID-ABBREVIATIONS							
	Low Pressure PN 16/25 - ANSI 150			High Pressure ANSI 300/600				
	Standard	Silenced		Standard	Silenced			
		SR	SRS		SR	SRII	SRS	SRSII
Regulator	FL-BP	FL-BP-SR	FL-BP-SRS	FL	FL-SR	FL-SRII	FL-SRS	FL-SRSII
Regulator + Monitor	MFL-BP	MFL-BP-SR	MFL-BP-SRS	MFL	MFL-SR	MFL-SRII	MFL-SRS	MFL-SRSII
Regulator + Shut-off	BFL-BP	BFL-BP-SR	BFL-BP-SRS	BFL	BFL-SR	BFL-SRII	BFL-SRS	BFL-SRSII

Note : Types SRII and SRSII silencers are not available for DN 40 and DN 65 sizes. Sizes DN 200 and 250 are available only with SRII or SRSII silencers. SRS/SRSII silenced solutions have a widened output flange.

Also available: SRS-R reinforced version; version with widened output but without a built-in silencer.

# FL Regulators

## Operation

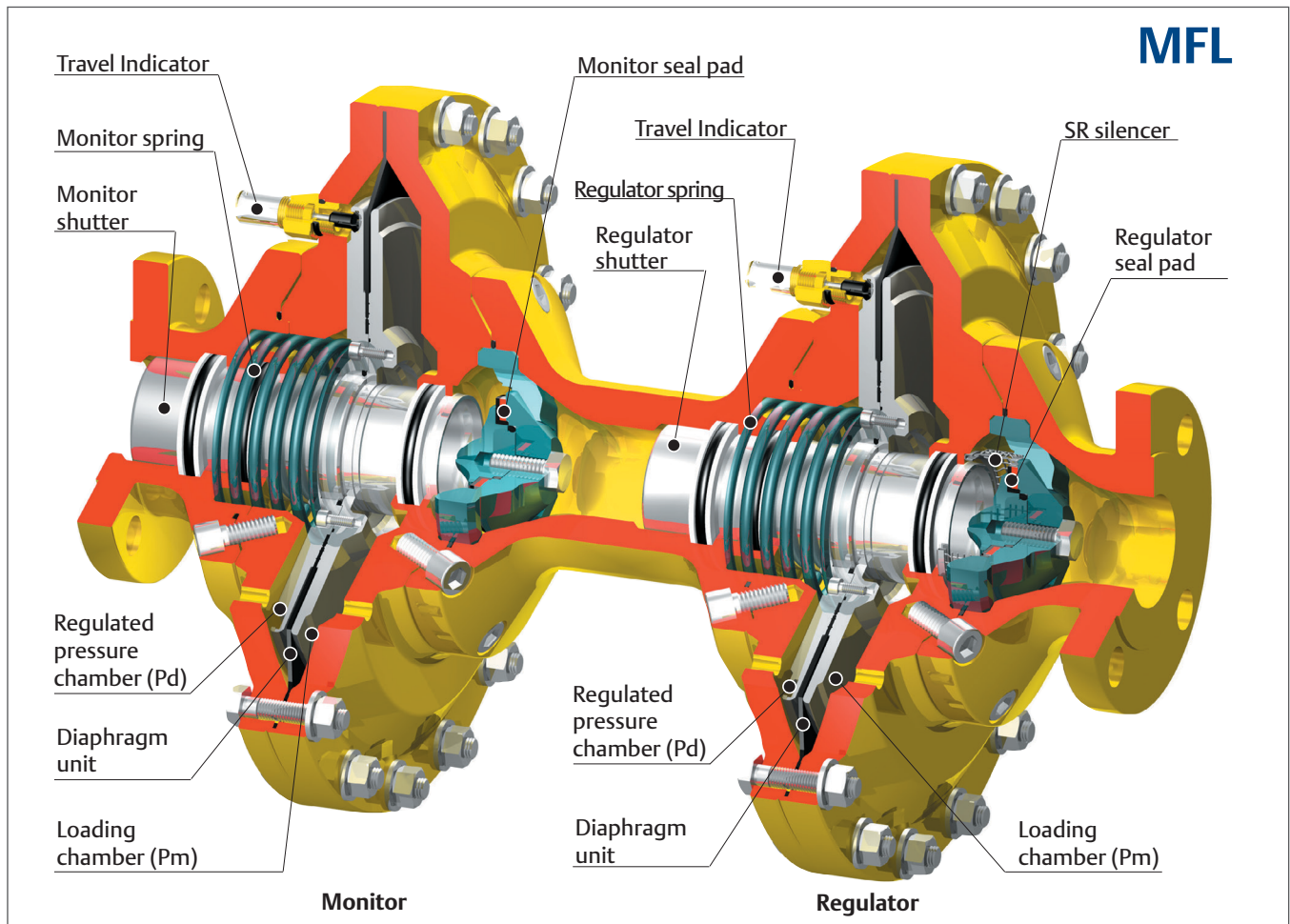

### HOW THE REGULATOR WORKS

The diaphragm unit (assembled to the shutter) divides the regulator control head into two chambers. One of the chambers is connected to regulated outlet pressure ( $P_d$ ), and the other to loading pressure ( $P_m$ ) produced by the pilot according to pressure downstream. Due to reduced loading pressure, the regulator spring acts on the diaphragm unit and closes the shutter.

The shutter moves to an open position when the force produced by loading pressure ( $P_m$ ) acting on the diaphragm unit becomes greater than the force produced by downstream regulated outlet pressure ( $P_d$ ) added to the load of the regulator spring. The shutter stays idle when the two forces are equal, under these conditions, downstream pressure is equal to the system's set value.

Any change in requested flow-rate produces a variation in downstream regulated outlet pressure and the regulator, controlled by the pilot, opens or closes to deliver the requested flow-rate while keeping downstream pressure stable.

### HOW THE MONITOR WORKS

The Monitor or emergency regulator is used as a safety device in gas pressure reduction systems. The purpose of this device is to protect the system against possible overpressure, while keeping the downstream line in service.

The monitor controls downstream pressure at the same point as the main regulator and is set a little higher than the latter. Under normal operation, the monitor is fully open as it detects a pressure value lower than its set value. If downstream pressure increases and exceeds the monitor set point, the monitor comes into operation and adjusts pressure to its own set value.

## Operation

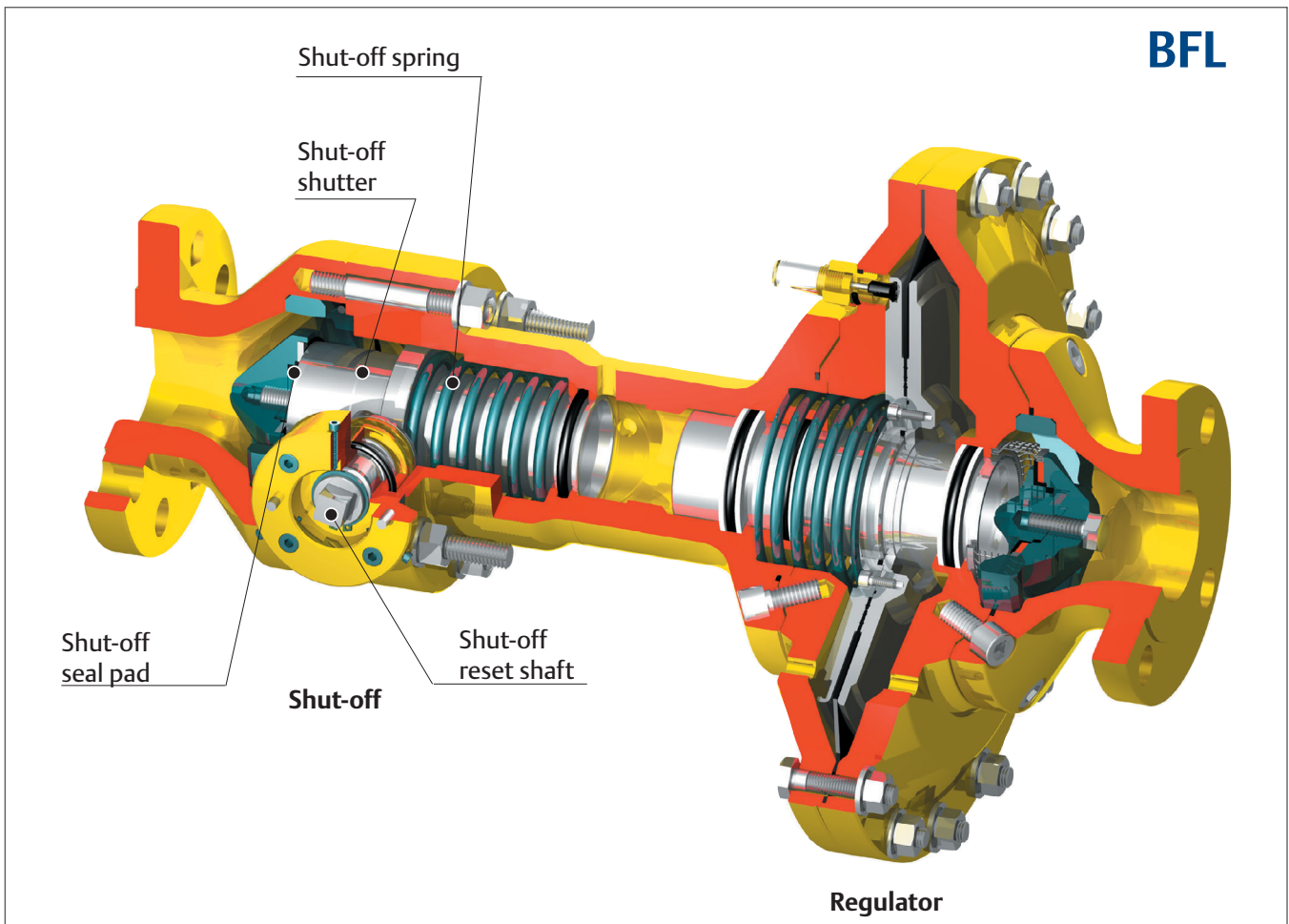

### HOW THE SHUT-OFF DEVICE WORKS

The slam-shut device has a shutter and individual seat. It functions independently of the regulator/monitor.

The shutter can only be hand-opened, by rotating the slam-shut reset shaft counter clockwise.

To keep the shutter open, the slam-shut controller series OS/80X or OS/80X-PN is used. Both series are designed to operate on maximum and minimum, maximum only, or minimum only pressure.

When the system's downstream pressure is at normal operating value, the slam-shut controller remains set and prevents the slam-shut reset shaft from turning by keeping the slam-shut shutter open.

When downstream pressure varies beyond it's set limits, the slam-shut controller releases the reset shaft and the shutter is closed by the thrust of the spring.

# FL Regulators

---

## Features

**Applications** FL series regulators are used in reduction, distribution and conveying stations of suitably filtered natural gas. This product has been designed to be used with fuel gases of 1st and 2nd family according to EN 437, and with other non aggressive and non fuel gases. For any other gases, other than natural gas, please contact your local sales agent.

## Technical Features

### Flange rating PN 16/25 - ANSI 150

Allowable pressure	PS	: up to 25 bar
Inlet pressure range	$b_{pu}$	: 0.2 to 25 bar
Set range	$W_d$	: 0.01 to 8 bar
Min. operating differential pres.	$\Delta p_{min}$	: 0.2 bar

### Flange rating ANSI 300/600

Allowable pressure	PS	: up to 100 bar
Inlet pressure range	$b_{pu}$	: 1 to 100 bar
Set range	$W_d$	: 0.5 to 80 bar
Min. operating differential pres.	$\Delta p_{min}$	: 0.5 bar

## Functional Features

Accuracy class	AC	: up to $\pm 1\%$
Lock-up pressure class	SG	: up to + 5%
Class of lock-up pressure zone	SZ	: up to 5%

### Shut-off device

Accuracy class	AG	: up to $\pm 1\%$
Response time	$t_a$	: $\leq 1$ s

### Flanged connections

Identical Inlet and outlet : DN 25 - 40 - 50 - 65 - 80 - 100 - 150\* - 200\* - 250\*  
Different Inlet and outlet : DN 25x100 - 40x150 - 50x150 - 65x200 - 80x250 - 100x250  
150x300\* - 200x400\* - 250x500\*

(\*) These sizes are not available in MFL and BFL configurations.

### Temperature

Standard version  
Working: -10 °C +60 °C

Low temperature version  
Working: -20 °C +60 °C

## Materials

Flanges and cover	Steel
Shutter and pad holder	Steel
Diaphragms	Nitrile NBR with PVC coating
O-ring	Nitrile NBR, fluorocarbon FKM
Pads	Nitrile NBR, fluorocarbon FKM, Polyurethane PU

## Calculation Procedures

<b>Symbols</b>	Q = Natural gas flow rate in Stm <sup>3</sup> /h	C <sub>g</sub> = Flow rate coefficient
	P1 = Absolute inlet pressure in bar	C1 = Body shape factor
	P2 = Absolute outlet pressure in bar	d = Relative density of the gas

## Flow Coefficients

DN		FL-BP* FL*	FL-BP-SR* FL-SR*	FL-BP-SRII FL-SRII	FL-BP-SRS FL-/SRS	FL-/SRSII	MFL-BP* MFL*	MFL-BP-SR* MFL-SR*	MFL-BP-SRS MFL-SRS	BFL-BP* BFL*	BFL-BP-SR* BFL-SR*	BFL-BP-SRS BFL-SRS
25	C <sub>g</sub>	590	580	540	570	530	440	430	400	430	420	370
	C1	32.1	33.4	33.5	36.6	37.1	30	30	32	30	30	32
40	C <sub>g</sub>	1400	1350	-	1200	-	1130	1100	1020	1130	1110	970
	C1	28	28	-	30	-	29	29	31	29	29	31
50	C <sub>g</sub>	2300	2200	2000	1900	1700	1850	1800	1600	1850	1800	1530
	C1	32.6	33.7	33.4	38.9	38.0	28	28	30	28	28	30
65	C <sub>g</sub>	3500	3350	-	2900	-	2800	2700	2450	2850	2750	2360
	C1	29	29	-	31	-	30	30	32	30	30	32
80	C <sub>g</sub>	5200	5000	4400	4000	3500	4100	4000	3550	4150	4050	3390
	C1	32.1	33.0	30.0	35.8	34.4	30	30	32	30	30	32
100	C <sub>g</sub>	8000	7400	6500	6200	5400	6800	6600	5800	6900	6700	5490
	C1	32.1	32.7	32.9	37.7	37.8	28	28	30	28	28	30
150	C <sub>g</sub>	20,300	17,800	16,200	13,490	12,830	-	-	-	-	-	-
	C1	27.6	29.8	31.7	33.9	34.2	-	-	-	-	-	-
200	C <sub>g</sub>	30,900	-	25,335	-	20,100	-	-	-	-	-	-
	C1	28.6	-	32.3	-	39.0	-	-	-	-	-	-
250	C <sub>g</sub>	52,100	-	42,500	-	33,300	-	-	-	-	-	-
	C1	32.3	-	35.5	-	32.7	-	-	-	-	-	-

(\*) Values also apply to widened outlet versions

Note: For other configurations, please contact our Technical Department.

**Flow rate Q** Sub-critical state with:  $P2 > \frac{P1}{2}$

$$Q = 0.525 \cdot C_g \cdot P1 \cdot \sin \left( \frac{3417}{C1} \cdot \sqrt{\frac{P1-P2}{P1}} \right)^{\text{Deg}}$$

Critical state with:  $P2 \leq \frac{P1}{2}$

$$Q = 0.525 \cdot C_g \cdot P1$$

For other gases with different densities, the flow rate calculated with the above formulas must be multiplied by the correction factor:

$$F = \sqrt{\frac{0.6}{d}}$$

Gas	Relative Density d	Factor F
Air	1	0.78
Butane	2.01	0.55
Propane	1.53	0.63
Nitrogen	0.97	0.79

# FL Regulators

**DN Sizes** Calculate the required  $C_g$  with the following formula:

**Sub-critical with:**  $P_2 > \frac{P_1}{2}$

$$C_g = \frac{Q}{0.525 \cdot P_1 \cdot \sin \left( \frac{3417}{C_1} \cdot \sqrt{\frac{P_1 - P_2}{P_1}} \right)^{Deg}}$$

**Critical state with:**  $P_2 \leq \frac{P_1}{2}$

$$C_g = \frac{Q}{0.525 \cdot P_1}$$

N.B. The above formulas apply to natural gas flow rate only. If the flow rate value (Q) refers to other gasses, divide it by the correction factor F (see table).

Select the diameter of the regulator with  $C_g$  higher than calculated value (see table).  
After finding the DN of the regulator, check that gas speed on the seat does not exceed 120 m/sec, using the following formula:

$$V = 345.92 \cdot \frac{Q}{DN^2} \cdot \frac{1 - 0.002 \cdot P_u}{1 + P_u}$$

- V = Velocity (m/s)
- 345.92 = Numerical constant
- Q = Flow rate under standard conditions (Stm<sup>3</sup>/h)
- DN = Regulator nominal diameter (mm)
- $P_u$  = Inlet pressure in relative value (bar)

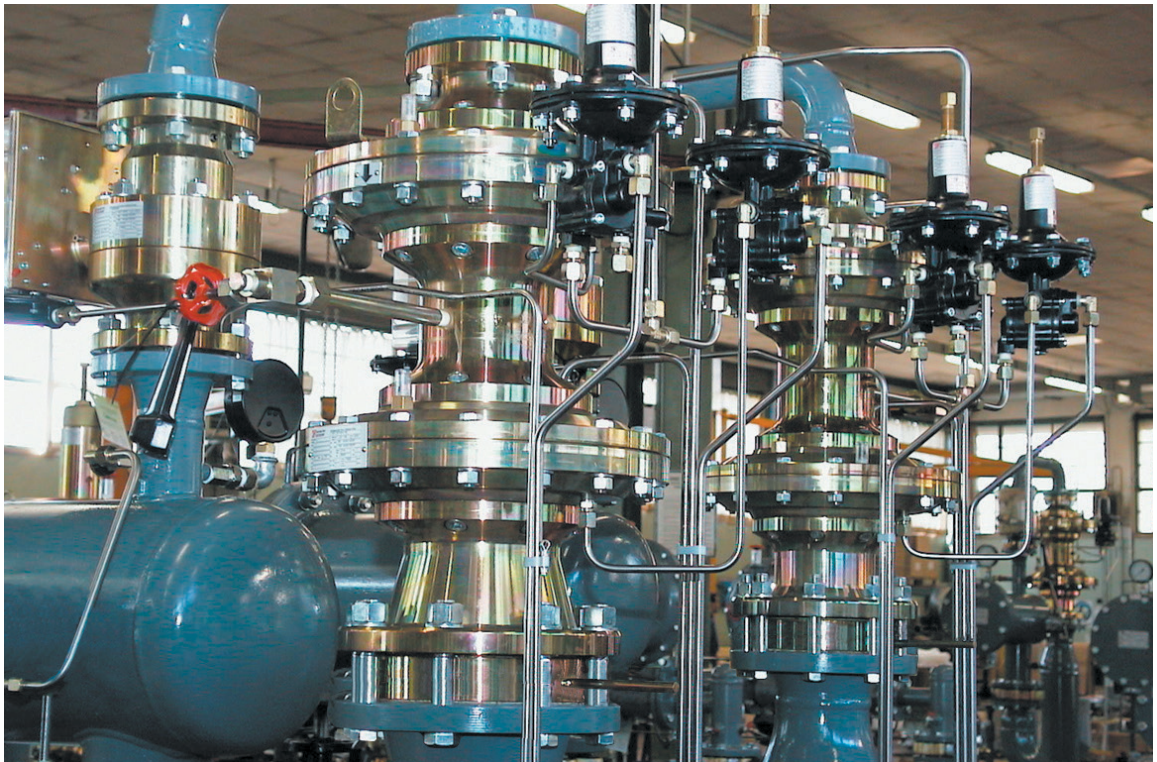

*Regulation Skid Detail*



## Slam-Shut Controller

The following slam-shut controllers are used with BFL series regulator with built-in shut-off device:

- **OS/80X series:** Spring loaded pneumatic device
- **OS/80X-PN series:** Pneumatic device controlled by PRX-PN series pilots

### OS/80X

The OS/80X series slam-shut controller is supplied in different models according to set ranges required.

#### Technical Features

Model	Servomotor Body Resistance (bar)	Overpressure Set Range $W_{do}$ (bar)		Underpressure Set Range $W_{du}$ (bar)	
		Min.	Max.	Min.	Max.
OS/80X-BP	5	0.03	2	0.01	0.60
OS/80X-BPA-D	20				
OS/80X-MPA-D	100	0.50	5	0.25	4
OS/80X-APA-D		2	10	0.30	7
OS/84X		5	41	4	16
OS/88X		18	80	8	70

#### Materials

##### OS/80X

Servomotor body	OS/80X-BP, OS/80X-BPA-D OS/80X-MPA-D, OS/80X-APA-D	Aluminum Steel
Diaphragm	Nitrile NBR with PVC coating	
O-ring	Nitrile NBR, fluorocarbon FKM	

##### OS/84X, OS/88X

Servomotor body	Brass
Lip seal	Teflon PTFE
O-ring	Nitrile NBR, fluorocarbon FKM



OS/80X-BP

### OS/80X-PN

The OS/80X-PN series slam-shut controller is supplied in two models:

**OS/80X-PN:** Pressure range 0.5 to 40 bar

Appliance made of an OS/80X-APA-D set at about 0.4 bar and a variable number of PRX/182-PN pilots for overpressure and PRX/181-PN for underpressure, as many as necessary to control different points of the installation.

**OS/84X-PN (Safety Accessory):** Pressure range 30 to 80 bar

Appliance made of an OS/84X set at about 20 bar and a variable number of PRX-AP/182-PN pilots for overpressure and PRX-AP/181-PN for underpressure, as many as necessary to control different points of the installation.

#### Technical Features

Model	Servomotor Body Resistance (bar)	Overpressure Set Range $W_{do}$ (bar)		Underpressure Set Range $W_{du}$ (bar)	
		Min.	Max.	Min.	Max.
OS/80X-PN	100	0.5	40	0.5	40
OS/84X-PN	100	30	80	30	80

#### Materials

##### PRX/181/182-PN, PRX-AP/181/182-PN

Body:	Steel
Diaphragm:	Nitrile NBR with PVC coating
O-ring:	Nitrile NBR, fluorocarbon FKM

# FL Regulators

## Pilots

### PS/ Series



FL series regulators are equipped with the PS/ or PRX/ series pilots.

Application	Allowable Pressure PS (bar)	Set Range $W_d$ (bar)	Body and Covers Material
Regulator or Monitor			
PS/79-1	25	0.01 - 0.5	Aluminium
PS/79-2		0.5 - 3	

1/4" NPT female threaded connections



Application			Allowable Pressure PS (bar)	Set Range $W_d$ (bar)	Body and Covers Material
Regulator or Monitor	Operating Monitor				
	Regulator	Monitor			
PS/79	PSO/79	REO/79	100	0.5 - 40	Steel
PS/80	PSO/80	REO/80		1.5 - 40	

1/4" NPT female threaded connections

All PS/ series pilots are supplied with a filter (5 $\mu$  filtering degree) and built-in pressure stabilizer, with the exception of pilots PSO/79 and PSO/80.

### PRX/ Series



Application			Allowable Pressure PS (bar)	Set Range $W_d$ (bar)	Body and Covers Material
Regulator or Monitor	Operating Monitor				
	Regulator	Monitor			
PRX/120	PRX/120	PRX/125	100	1 - 40	Steel
PRX-AP/120	PRX-AP/120	PRX-AP/125		30 - 80	

1/4" NPT female threaded connections

The SA/2 pressure pre-reducer must be used with PRX/ series pilots.

### SA/2



The pressure pre-reducer is equipped with a 5 $\mu$  filtering degree filter and is suitable for heating.

Model	Allowable Pressure PS (bar)	Supplied Pressure	Body and Covers Material
SA/2	100	3 bar + Downstream pressure	Steel

1/4" NPT female threaded connections

### FU



When the pressure difference between upstream and downstream is below 10 bar, SA/2 can be used with the following FU filter.

Model	Allowable Pressure PS (bar)	Filtering Degree	Body and Covers Material
FU	100	5 $\mu$	Steel

1/4" NPT female threaded connections

### Booster Valves



Model	Allowable Pressure PS (bar)	Set Range $W_d$ (bar)	Body and Covers Material
V/31-2	19	0.015 - 0.55	Aluminium
PRX/131	100	0.5 - 40	Steel
PRX-AP/131		30 - 80	

1/4" NPT female threaded connections

## Operating Monitor and Booster Valve

### OPERATING MONITOR

The “operating monitor” has two functions: under normal duty, it reduces pressure in the intermediate section between the two regulators, but, if the main regulator fails, it comes into operation as an emergency regulator.

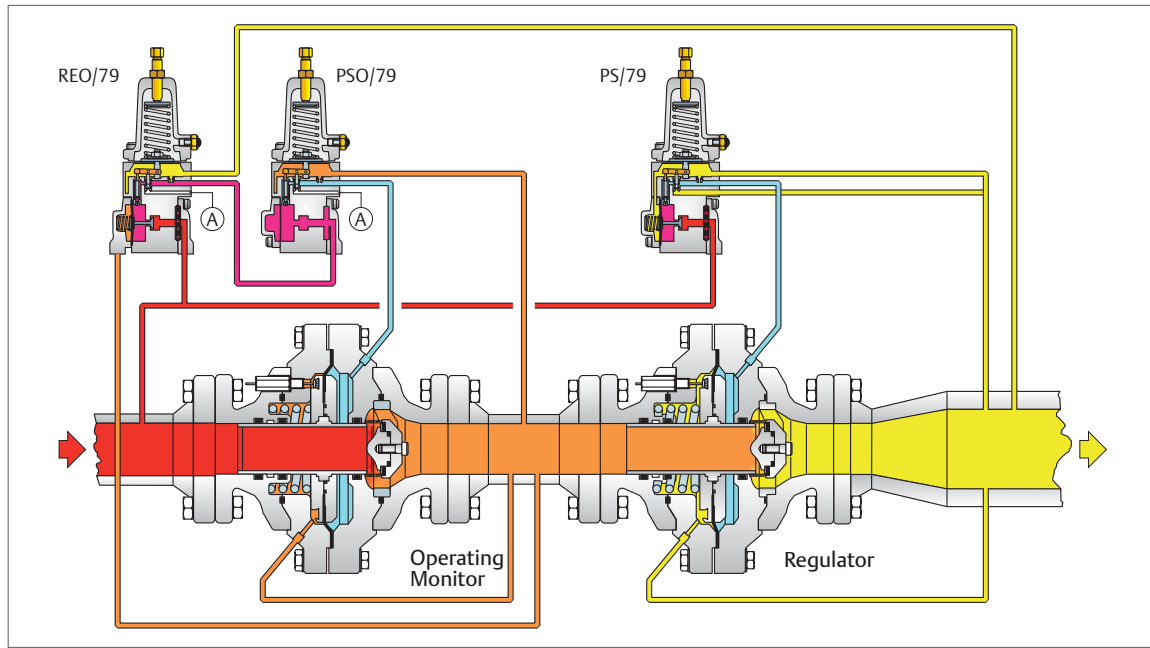

### BOOSTER VALVE

The booster valve is fitted on the monitor-regulator system which branches off from the monitor drive pressure circuit, so that the monitor operates more quickly. For size DN 250 the booster valve is always installed also on the regulator.

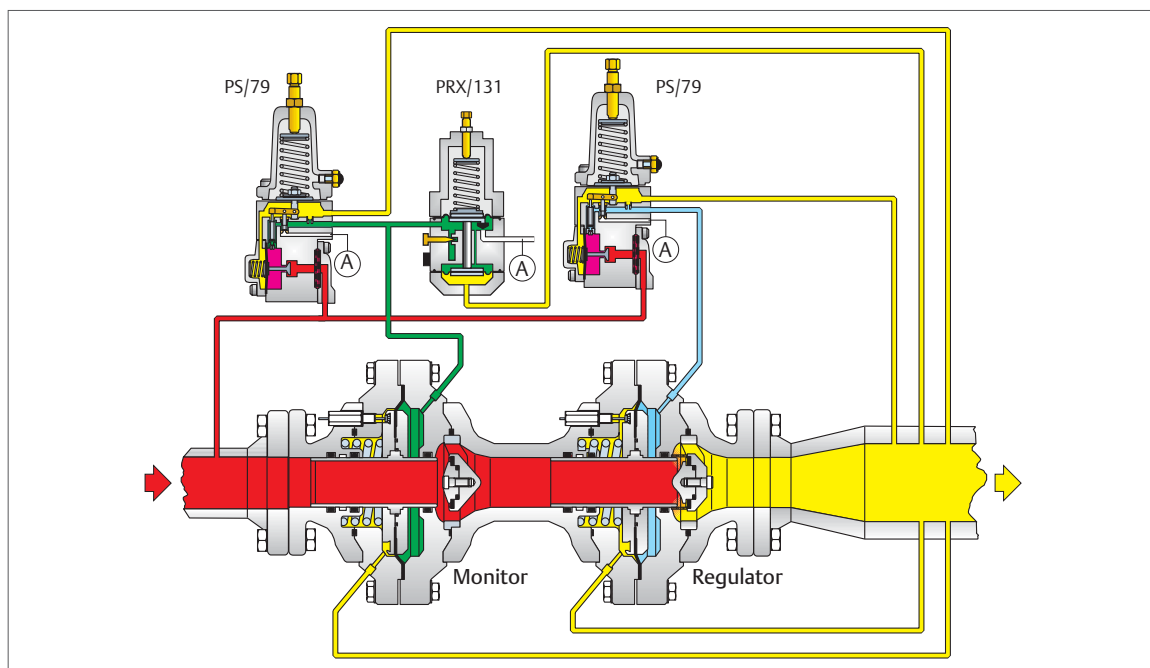

- Inlet pressure
  - Intermediate pressure
- Regulator loading pressure
  - Monitor loading pressure
- Stabilized pressure
  - Outlet pressure
- Ⓐ Downstream or to a safe area

# FL Regulators

## Silencers

### SR

This silencer is fitted near the regulator shutter and is highly efficient up to a theoretical gas velocity of 80 m/s calculated at the outlet flange.

Beyond 80 m/s, it could be necessary to reduce the noise generated by the expansion cone usually installed downstream of the regulator.

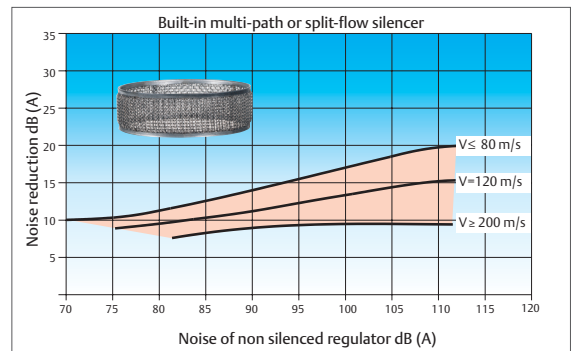

### SRII

The SRII silencer is the next generation of Type SR and is used in case of extreme service conditions (dirty gas, high pressure drops, and high gas velocities).

Noise characteristics are very similar to the standard SR.

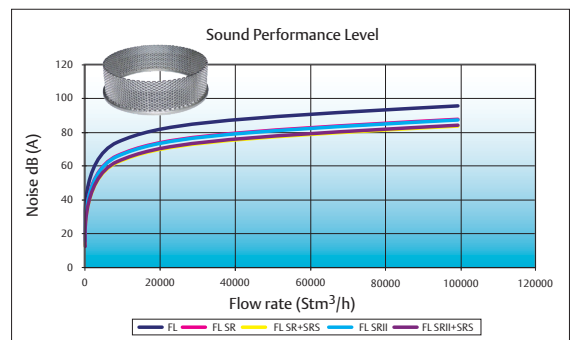

### SRS

The SRS silencer consists of an SR/SRII silencer plus a widened outlet flange in which a second silencer is fitted.

The second silencer has an initial multi-path section and a second multi-stage section.

This silencer is highly efficient under all operating conditions and is not limited by the theoretical speed on the regulator outlet flange.

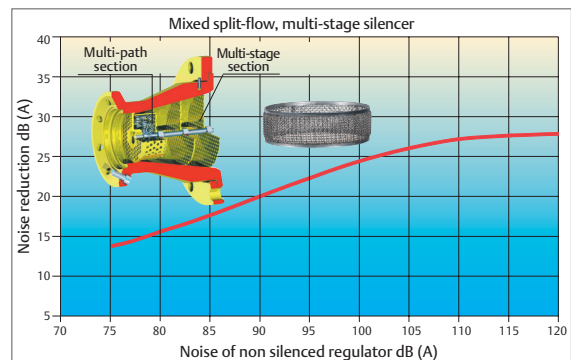

### STP

The STP silencer consists of one or more porous channels clad with soundproofing material.

Habitually used down-stream of SRS silencers but can also be combined with the SR silencer.

Overall reduction in noise level is the sum of the reduction produced by SR/SRII or SRS plus the STP induced reduction.

Sound penetrates inside the soundproofing layer and is transformed into heat by friction.

The silencer is fitted in the pipe and is secured with two flanges.

Two types of silencers are supplied:

- STP10 10 dB (A) attenuation, with length of approximately 1 m
- STP10 20 dB (A) attenuation, with length of approximately 2 m

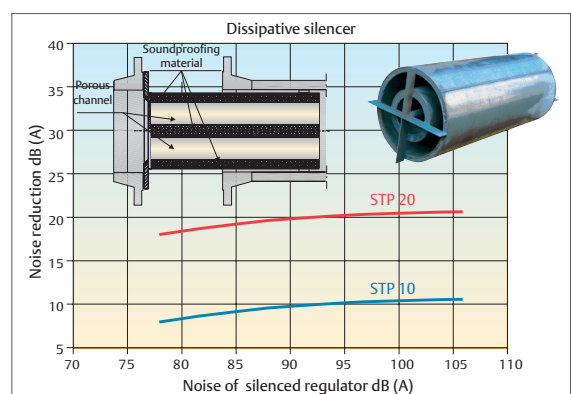

## Accessories

### PROPORTIONAL TRAVEL TRANSMITTER

In order to communicate the valve position, a potentiometer-type straightaway position transmitter is used connected to the regulator travel indicator. Thanks to this transducer, it is possible to know the valve position and thus have correct information on the regulator operating condition.

It is supplied in two models:

- PA1/25 suitable for FL DN 25 to 65
- PA1/50 suitable for FL DN 80 to 200
- PA1/75 suitable for FL DN 250

This transducer features a single element as foreseen by EN 50020 standards and can thus be used in hazardous areas.

Single element transducers, if fitted in intrinsic safety circuits, should be protected through suitable safety barriers anyway.



Model		PA1/25	PA1/50	PA1/75
Useful electrical travel	mm	25	50	75
Resistance	kΩ	1	5	5
Resolution	mm	infinite		
Suggested current	μA	<1		
Max. current	mA	≤10		
Max. voltage	V	25	60	
Working temperature	°C	-30 °C +100 °C		

### PROXIMITY SWITCH

In order to send the shut-off or the regulator/monitor opening/closing signal, a proximity switch suitable for installation in hazardous area is used.

The use of this switch foresees the application of an intrinsic safety separation barrier which should be installed in safe area.

The distance between the proximity switch and the barrier should be calculated according to the type of gas and installation electrical specifications.

The proximity switch should be positioned at about 0.5 mm from the stem (S). The adjustment is made by means of adjusting nuts.

On request it is possible to supply the pilot in the version with two proximity switches in order to indicate extreme positions of valve opening/closing.

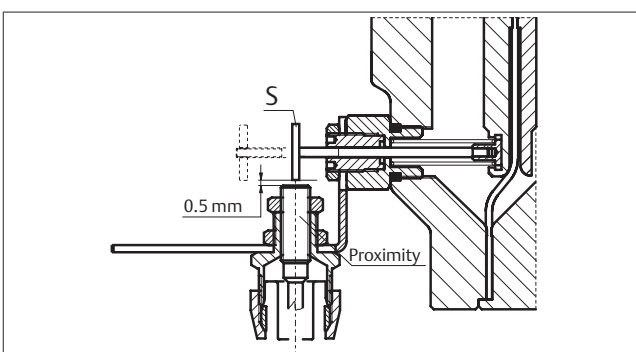

*Regulator/Monitor Installation*

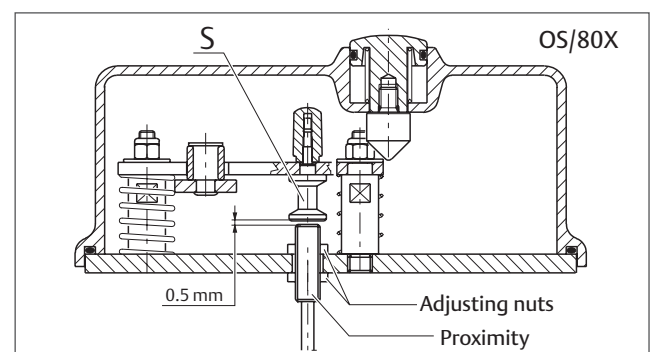

*Pilot Installation*

# FL Regulators

## Accessories

### ELECTROVALVE FOR REMOTE CONTROLLED CLOSURE

The OS/80X and the OS/80X-PN equipped with a shut-off device for minimum pressure, can be equipped with a 3-way valve with explosion-proof construction to permit remote-controlled closure.

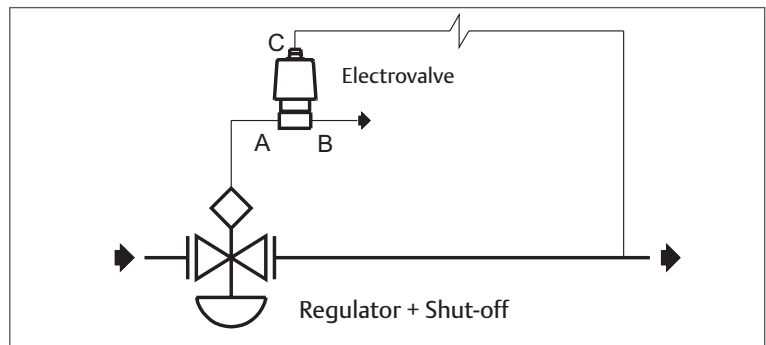

### IT/3V THREE-WAY VALVE FOR SETTING CONTROL ( $P_u$ max 50 bar)

The three-way valve allows the OS/80X operation and setting control, without having to change the regulator setting.

The valve is installed on the OS/80X control line and it must be connected to a suitable pressure source that is capable of reaching the settings of the OS/80X.

The IT/3V three-way valve is of the spring-return type and it is equipped with a safety lock plate (B) on the control knob (Q).

When the plate (B) is pivoted, pressure on the knob (Q) makes it possible to put the sensing member into communication with a pressure source, thus making it possible to perform operation and setting tests.

Upon completion of the procedures, releasing the knob will reset normal running conditions. The safety lock plate (B) on the knob prevents accidental maneuvers.

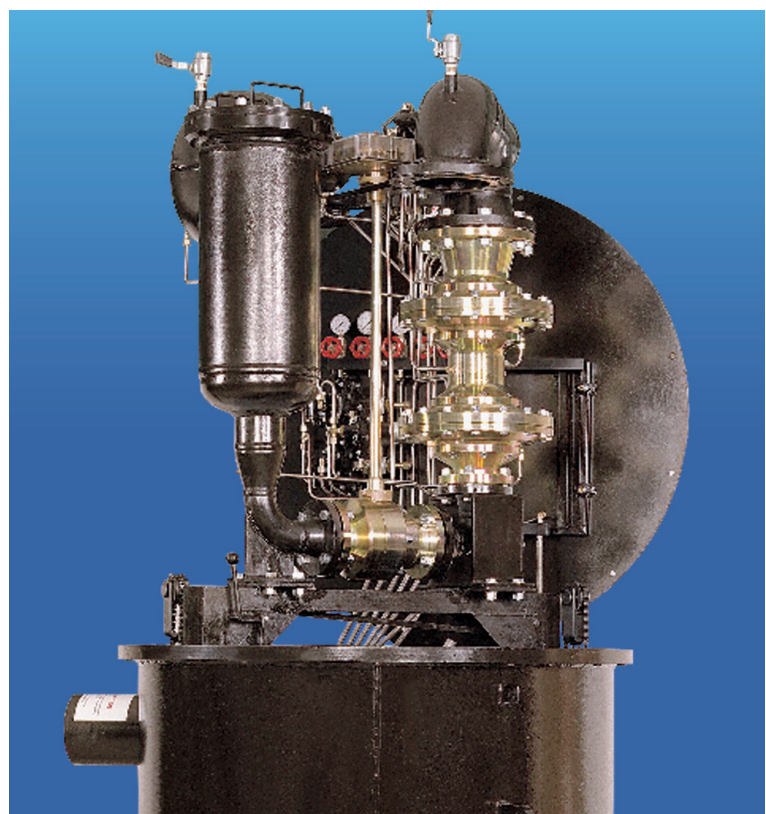
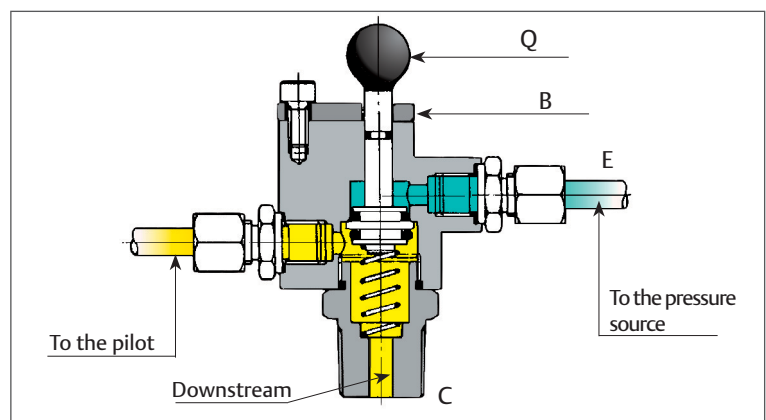

MIF/65 Underground Module

## Installation

FL • FL-SR • FL-SRII • FL-SRS • FL-SRSII • FL with Widened Outlet

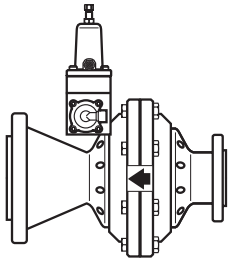

Horizontal installation  
Right to Left

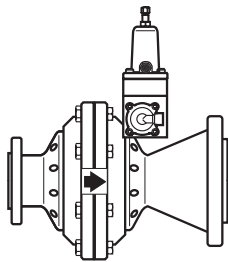

Horizontal installation  
Left to Right

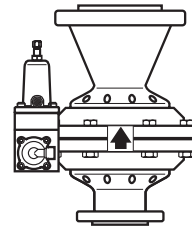

Vertical installation  
Upward

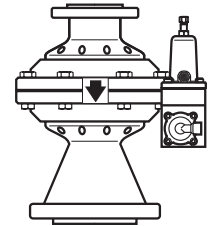

Vertical installation  
Downward

MFL • MFL-SR • MFL-SRII • MFL-SRS • MFL-SRSII • MFL with Widened Outlet

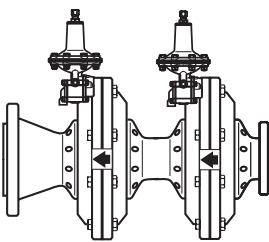

Horizontal installation  
Right to Left

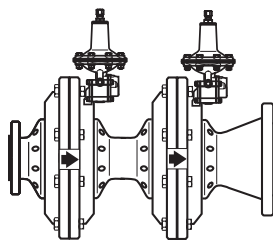

Horizontal installation  
Left to Right

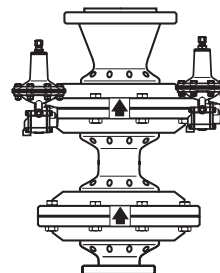

Vertical installation  
Upward

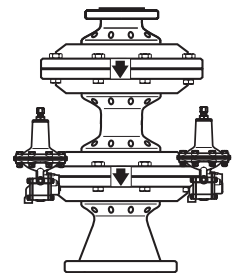

Vertical installation  
Downward

BFL • BFL-SR • BFL-SRII • BFL-SRS • BFL-SRSII • BFL with Widened Outlet

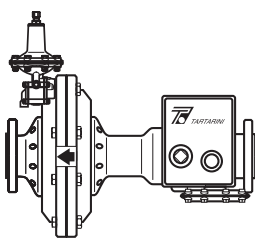

Horizontal installation  
Right to Left

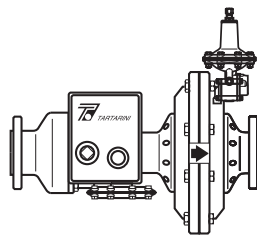

Horizontal installation  
Left to Right

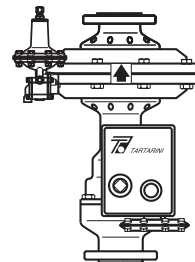

Vertical installation  
Upward

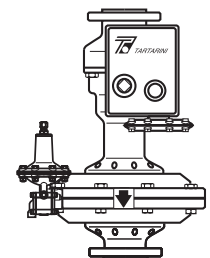

Vertical installation  
Downward

# FL Regulators

## Maintenance Benefits

During the maintenance operations the pad is easily accessible and, unlike in other regulators, there is no need to remove the regulator from the line or to disassemble the diaphragm in order to replace the pad.

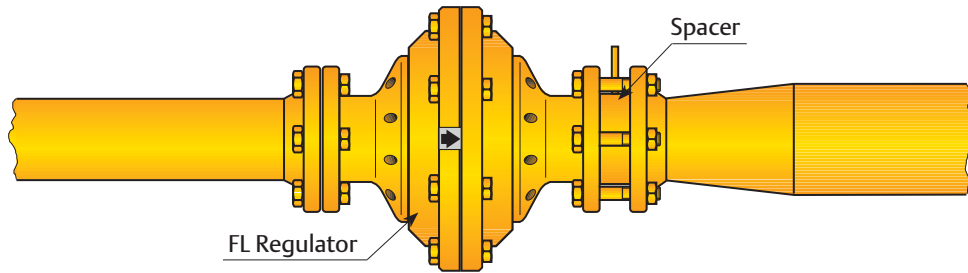

A special spacer has been installed downstream of the regulator so that, once the spacer is removed, the outlet flange can also be easily removed for ready access to the pad-holder.

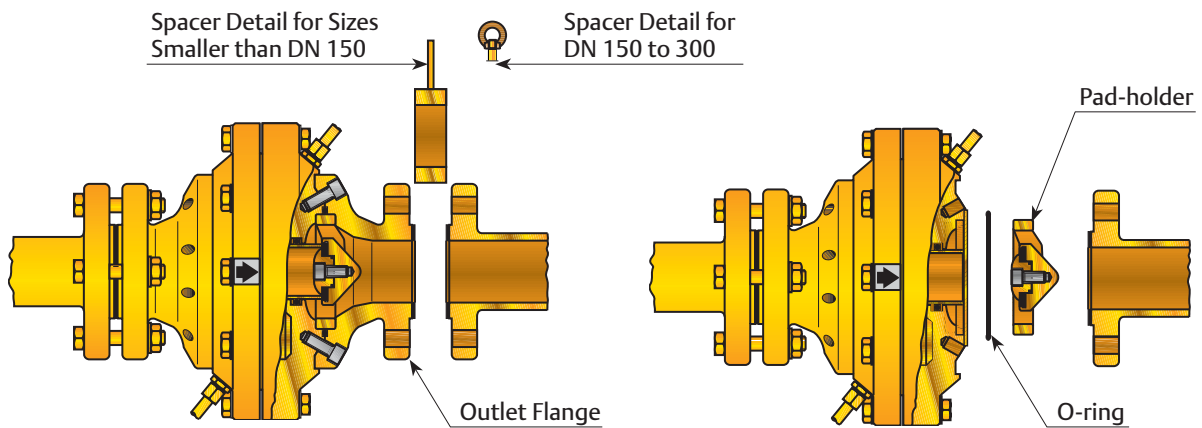

Spacer overall dimensions, DN is referred to the outlet flange of the regulators.

DN	S
25	30
40	40
50	50
65	60
80	60
100	60
150	80
200	100
250*	100
300*	80



\*Only on request



## Examples of Connections

**PS/79-1  
PS/79-2  
Series**

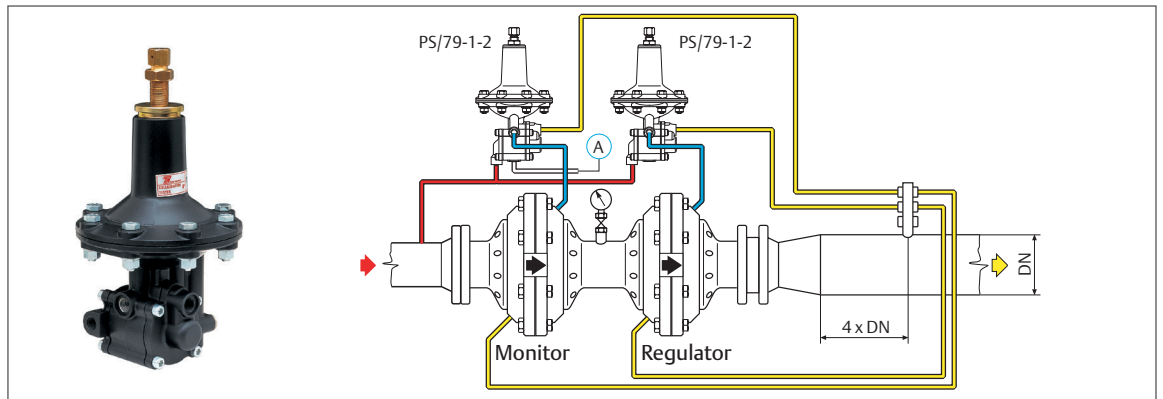

**PS/79  
Series**

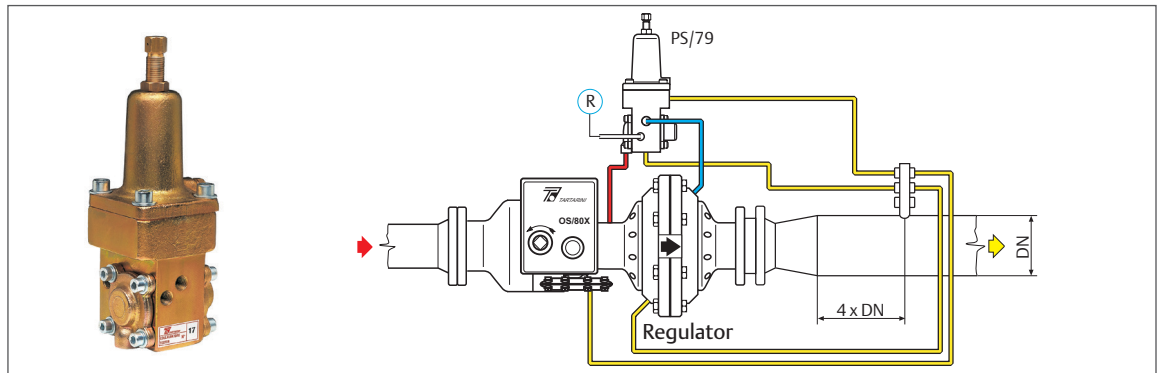

**PS/80  
Series**

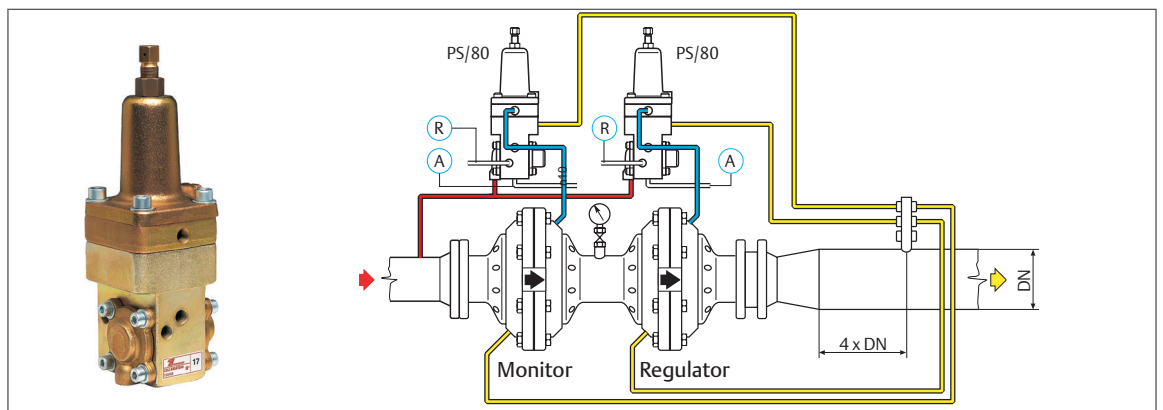

**PRX  
Series**

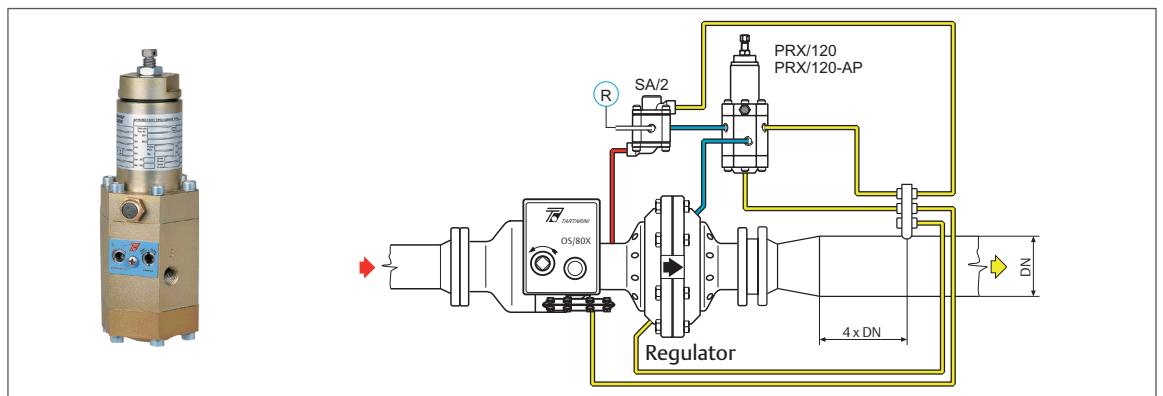

■ Inlet pressure    
 ■ Loading pressure    
 ■ Outlet pressure    
 (A) Downstream or to a safe area    
 (R) To the heating system

# FL Regulators

## Dimensions and Weights

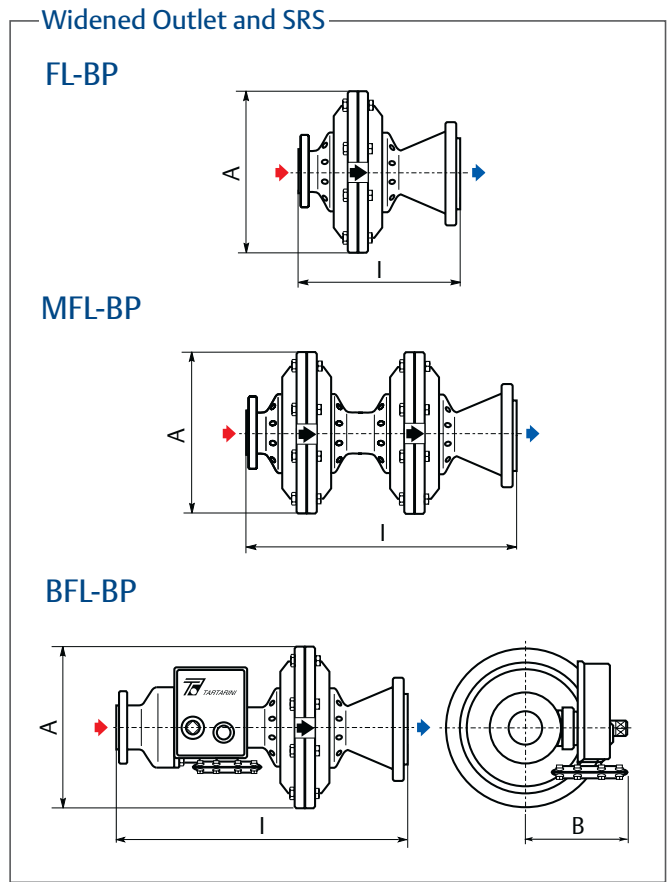
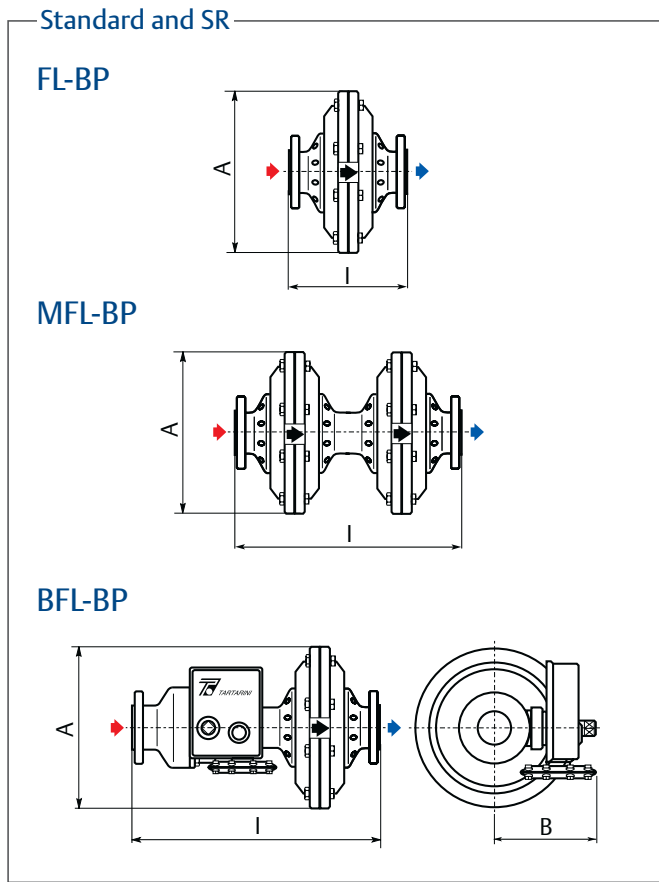

DN	Face to Face - I (mm)			Dimensions (mm)	
	PN 16 - ANSI 150			A	B
	FL-BP	MFL-BP	BFL-BP		
25	184	360	355	285	199
40	222	424	410	306	206
50	254	510	485	335	213
65	276	542	530	370	227
80	298	564	560	400	245
100	352	675	670	450	269
150	451	-	-	590	-
200	543	-	-	653	-
250	730	-	-	785	-

DN	Face to Face - I (mm)			Dimensions (mm)	
	PN 16 - ANSI 150			A	B
	FL-BP	MFL-BP	BFL-BP		
25x100	290	466	461	285	199
40x150	350	552	538	306	206
50x150	380	636	611	335	213
65x200	420	686	674	370	227
80x250	470	736	732	400	245
100x250	525	848	843	450	269
150x300	630	-	-	590	-

Standard and SR Weights (kg)			
DN	PN 16 - ANSI 150		
	FL-BP	MFL-BP	BFL-BP
25	24	48	38
40	37	77	50
50	48	97	60
65	68	140	100
80	83	168	132
100	105	239	197
150	255	-	-
200	620	-	-
250	1190	-	-

Widened Outlet and SRS Weights (kg)			
DN	PN 16 - ANSI 150		
	FL-BP	MFL-BP	BFL-BP
25x100	30	54	44
40x150	47	87	60
50x150	58	107	70
65x200	90	162	122
80x250	128	213	177
100x250	150	284	242
150x300	380	-	-

All constructions use threaded 1/4" NPT female impulse connections.

## Dimensions and Weights

Standard and SR/SRII

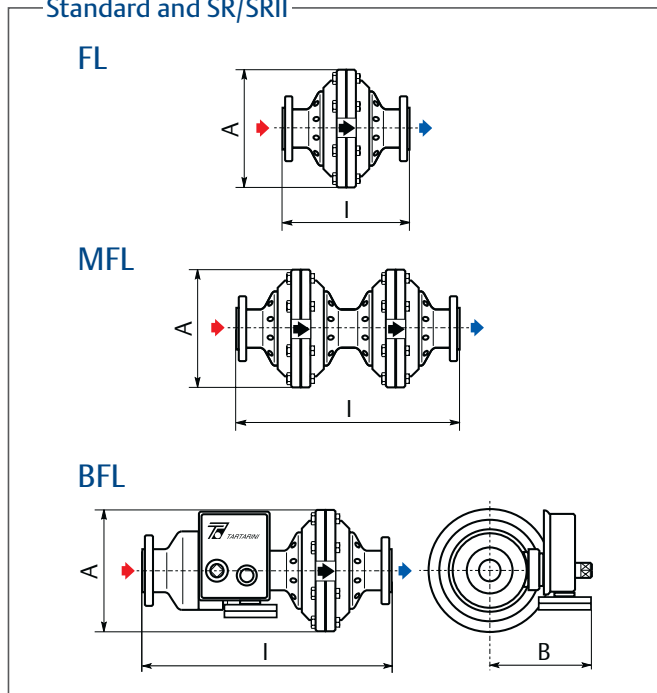

Widened Outlet and SRS/SRSII

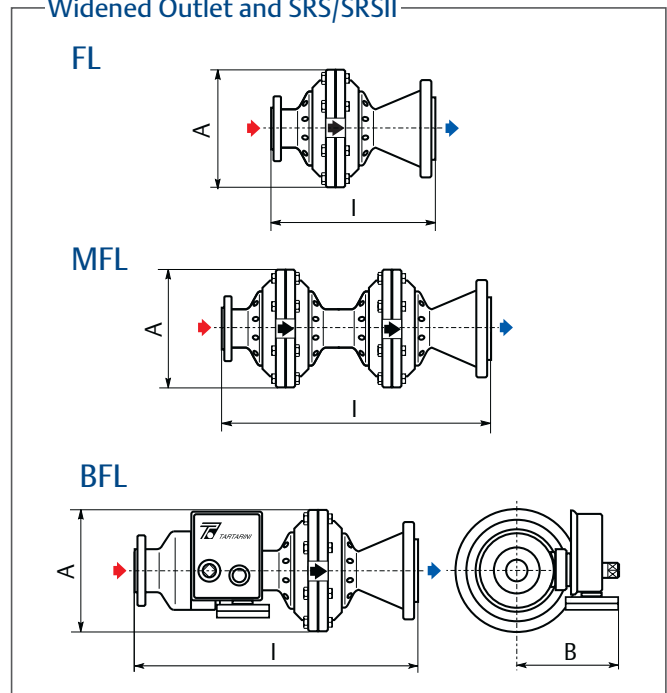

DN	Face to Face - I (mm)			Dimensions (mm)	
	ANSI 300 - ANSI 600			A	B
	FL	MFL	BFL		
25	210	385	390	225	199
40	251	450	445	265	206
50	286	535	515	287	213
65	311	574	560	355	227
80	337	600	600	400	245
100	394	720	710	480	269
150	508	-	-	610	-
200	610	-	-	653	-
250	752	-	-	785	-

Note: For DN 200 ANSI 300 face to face is 568 mm, for DN 250 ANSI 300 face to face is 708 mm.

DN	Face to Face - I (mm)			Dimensions (mm)	
	ANSI 300 - ANSI 600			A	B
	FL	MFL	BFL		
25x100	300	475	480	225	199
40x150	370	569	564	265	206
50x150	400	649	629	287	213
65x200	440	703	689	355	227
80x250	500	763	763	400	245
100x250	525	851	841	480	269
150x300	660	-	-	610	-
200x400	750	-	-	653	-
250x500	965.5	-	-	785	-

Note: SRS-R reinforced version is available up to DN 150, add 14 mm to face to face dimension. For DN 200x400 ANSI 300 face to face is 722 mm.

Standard and SR/SRII Weights (kg)

DN	ANSI 300 - ANSI 600		
	FL	MFL	BFL
25	31	73	49
40	47	96	71
50	60	113	90
65	88	174	129
80	148	296	208
100	201	364	297
150	480	-	-
200	620	-	-
250	1190	-	-

Widened Outlet and SRS/SRSII Weights (kg)

DN	ANSI 300 - ANSI 600		
	FL	MFL	BFL
25x100	45	87	63
40x150	74	123	98
50x150	87	140	117
65x200	135	220	176
80x250	233	380	293
100x250	286	450	382
150x300	620	-	-
200x400	900	-	-
250x500	1623	-	-

All constructions use threaded 1/4" NPT female impulse connections

✉ Webadmin.Regulators@emerson.com

🔍 Tartarini-NaturalGas.com

📘 Facebook.com/EmersonAutomationSolutions

🌐 LinkedIn.com/company/emerson-automation-solutions

🐦 Twitter.com/emr\_automation

## Emerson Automation Solutions Regulator Technologies

### Americas

McKinney, Texas 75070 USA  
T +1 800 558 5853  
+1 972 548 3574

### Europe

Bologna 40013, Italy  
T +39 051 419 0611

### Asia Pacific

Singapore 128461, Singapore  
T +65 6777 8211

### Middle East and Africa

Dubai, United Arab Emirates  
T +971 4 811 8100

### Emerson Process Management s.r.l

Emerson Automation Solutions - Stabilimento di/Site of: Castel Maggiore - Bologna  
Sede Legale/Legal Entity: Piazza Meda 5, 20121 Milano, Italy  
Sede Amministrativa/Administrative Headquarters: OMT Tartarini, Via Clodoveo Bonazzi 43,  
40013 Castel Maggiore (Bologna), Italy  
C.F. - P.I. e R.I. di MI 13186130152 - REA di MI/n.1622916  
Direz. e Coord. (art. 2497 bis CC): EMERSON ELECTRIC CO. St. Louis (USA) Socio Unico

D104049X012 © 2015, 2021 Emerson Process Management Regulator Technologies, Inc. All rights reserved. 09/21.  
The Emerson logo is a trademark and service mark of Emerson Electric Co. All other marks are the property of their prospective owners. Tartarini™ is a mark owned by one of the companies in the Emerson Automation Solutions business unit of Emerson Electric Co.

The contents of this publication are presented for informational purposes only, and while every effort has been made to ensure their accuracy, they are not to be construed as warranties or guarantees, express or implied, regarding the products or services described herein or their use or applicability. All sales are governed by our terms and conditions, which are available on request. We reserve the right to modify or improve the designs or specifications of our products at any time without notice.

Emerson Process Management Regulator Technologies, Inc does not assume responsibility for the selection, use or maintenance of any product. Responsibility for proper selection, use and maintenance of any Emerson Process Management Regulator Technologies, Inc. product remains solely with the purchaser.

