

April 2023

FL Series Pilot-Operated Pressure Regulator

SUMMARY

Introduction	1
PED Categories and Fluid Group	2
Characteristics	2
Labelling	3
Overpressure Protection	3
Transport and Handling	3
ATEX Requirements	4
Description	4
Pilots	5
Dimensions and Weights	6
Operation	8
Installation	9
Startup of the Regulator	13
Pilot Adjustment	14
Shutdown	14
Periodical Checks	14
Regulator Maintenance	14
Type OS/80X Slam-Shut Controller Maintenance	17
Type PRX/ and PS/ Pilot Maintenance	18
Type V/31-2 Booster Valve Maintenance	22
Type SA/2 Stabilizer Filter Maintenance	22
Waste Disposal Requirements	22
Spare Parts	22
Troubleshooting	23
Parts List	25
Schematic Assemblies.....	30



Figure 1. Regulator Type FL with PRX Pilot

Product Description

The FL Series pilot operated regulators are axial flow type with a single seat and counterbalanced shutter.

The following versions are available:

- FL:** Regulator
- MFL:** Regulator - Monitor
- BFL:** Regulator - Slam-shut Device

Type SR, SR11 and/or SRS silencers are also available.

All standard gas pressure devices (regulators and safety shut-off devices) used in assemblies will comply to EN 12186 and EN 12279 standards.

Any accessories (e.g. pilots or filters) used on the Emerson range of pressure regulators, with or without built-in safety shut-off devices, must be manufactured by one of the Emerson companies and bear that label.

If this is not respected, Emerson will not be responsible in the case of any inefficiency.

In a configuration with integrated safety shut-off device and pilot, when the maximum allowable pressures are different, the slam-shut device is the differential strength type.

INTRODUCTION

Scope of the Manual

This manual provides instructions for installation, startup, maintenance and spare parts ordering for the FL Series pilot operated regulators. It also contains information for the slam-shut controller, pilots, booster valves and filter.

Type FL

PED CATEGORIES AND FLUID GROUP

The FL Series regulators without built-in safety slam-shut devices (FL and MFL) may be used as a stand-alone safety accessory in a fail close configuration to protect pressure equipment under the Pressure Equipment Directive PED 2014/68/EU categories.

The technical features of the downstream equipment, protected by this regulator, should be classified under a higher category according to the Pressure Equipment Directive PED 2014/68/EU.

According to EN 14382, only in an integral strength and Class A type configuration (in both over and under pressure protection configurations), can the possible built-in safety slam-shut device (BFL) be classified as a safety accessory according to PED.

The minimum PS between slam-shut device and pilot shall be the PS of the safety accessory, complying to EN 14382 for integral strength types.

The technical features of the downstream equipment, protected by possible built-in safety slam-shut device (configuration BFL Class A and integral strength) shall be classified according to the Pressure Equipment Directive 2014/68/EU, see Table 1.

Table 1. PED Category for FL Series Regulators

PRODUCT SIZE	CATEGORY	FLUID GROUP
FL and MFL Type DN 25-40-50-65-80-100 DN 150 (Type FL or FL-BP only) DN 200 and 250 (Type FL only)	IV	1
BFL Type DN 25-40-50-65-80-100-150		

The built-in pressure accessories (e.g. pilots OS/80X, OS/80X-PN, PRX/, PS/ and V/31-2 Series or filters Type SA/2, FU/ and FD-GPL/) conform to Pressure Equipment Directive PED 2014/68/EU Article 4 Section 3 were designed and manufactured in accordance to the Sound Engineering Practice (SEP).

According to Article 4 Section 3, these “SEP” products must not bear the CE marking.

CHARACTERISTICS

Body Sizes and End Connection Styles

FL Series

FL-BP

DN 25 - 40 - 50 - 65 - 80 - 100 - 150 - 200 - 250
PN 16-25-40 UNI/ DIN
ANSI 150 flanged

FL-BP with Type SRS silencer or widened outlet

DN 25x100 - 40x150 - 50x150 - 65x200 - 80x250 - 100x250
150x300 - 200x400
PN 16-25-40 UNI/ DIN
ANSI 150 flanged

FL

DN 25 - 40 - 50 - 65 - 80 - 100 - 150 - 200 - 250
ANSI 300 - 600 flanged

FL with Type SRS/SRSII silencer or widened outlet

DN 25x100 - 40x150 - 50x150 - 65x200 - 80x250 - 100x250 - 150x300 - 200x400 - 250x500
ANSI 300 - 600 flanged

MFL Series

MFL-BP

DN 25 - 40 - 50 - 65 - 80 - 100
PN 16-25-40 UNI/ DIN
ANSI 150 flanged

MFL-BP with Type SRS silencer or widened outlet

DN 25x100 - 40x150 - 50x150 - 65x200 - 80x250 - 100x250
PN 16-25-40 UNI/ DIN
ANSI 150 flanged

MFL

DN 25 - 40 - 50 - 65 - 80 - 100
ANSI 300 - 600 flanged

MFL with Type SRS/SRSII silencer or widened outlet

DN 25x100 - 40x150 - 50x150 - 65x200 - 80x250 - 100x250
ANSI 300 - 600 flanged

BFL Series

BFL-BP

DN 25 - 40 - 50 - 65 - 80 - 100
PN 16-25-40 UNI/ DIN
ANSI 150 flanged

BFL-BP with Type SRS silencer or widened outlet

DN 25x100 - 40x150 - 50x150 - 65x200 - 80x250 - 100x250
PN 16-25-40 UNI/ DIN
ANSI 150 flanged

BFL

DN 25 - 40 - 50 - 65 - 80 - 100 - 150
ANSI 300 - 600 flanged

BFL with Type SRS/SRSII silencer or widened outlet

DN 25x100 - 40x150 - 50x150 - 65x200 - 80x250 - 100x250
ANSI 300 - 600 flanged

Maximum Operating Inlet Pressure⁽¹⁾⁽²⁾

PN 16: 16 bar
PN 25: 25 bar
ANSI 150: 20 bar
ANSI 300: 50 bar
ANSI 600: 100 bar

Outlet Set Pressure Ranges (Regulator)

PN 16 - ANSI 150: 0.01 to 8 bar
PN 25 - ANSI 300-600: 0.5 to 80 bar

Overpressure Set Range (built-in Slam-shut)

0.03 to 80 bar

Underpressure Set Range (built-in Slam-shut)

0.01 to 70 bar

Minimum/Maximum Allowable Temperature (TS)⁽¹⁾

See Nameplate

- The pressure/temperature limits indicated in this instruction manual or any applicable standard or code limitation should not be exceeded.
- At average ambient temperature.

Functional Features

Accuracy Class AC: Up to $\pm 1\%$
 Lockup Pressure Class SG: Up to $+ 5\%$
 Class of Lockup Pressure Zone SZ: Up to 5%

Slam-shut Device

Accuracy Class AG: $\pm 1\%$
 Response Time t_a : ≤ 1 second

Temperature

Standard Version: Working -10 to 60°C
 Low Temperature Version: Working -20 to 60°C

Materials

Flanges and cover: Steel
 Shutter and pad holder: Steel
 Diaphragms: Nitrile (NBR) with PVC coating
 O-ring: Nitrile (NBR), Fluorocarbon (FKM)
 Pads: Nitrile (NBR), Fluorocarbon (FKM), Polyurethane PU

OVERPRESSURE PROTECTION

The recommended safety pressure limitations are stamped on the regulator nameplate. If the Type FL does not have a built-in safety shut-off device, some type of overpressure protection is needed if the actual inlet pressure exceeds PS (see nameplate).

Downstream side pressure after safety shut-off device's intervention (in the built-in safety shut-off device configurations) shall stay within the actual maximum operating set-up range to avoid anomalous back pressures that can damage the safety shut-off device's pilot. Equipment's operation below the maximum pressure limitations does not preclude the possibility of damage from external sources or debris in the line.

Downstream overpressure protection shall be also provided if the safety shut-off device outlet pressure can be greater than the PS of the safety shut-off device pilot (differential strength type). The regulators and possible built-in safety shut-off device should be inspected for damage after any overpressure condition and intervention.

LABELLING

			Notified body XXXX	APPARECCHIO TIPO / DEVICE TYPE
MATERIALE / ANNO SERIAL Nr. / YEAR		/ Nota 2		Nota 1
REAZIONE FAIL SAFE MODE	FAIL OPEN <input type="checkbox"/>	FAIL CLOSE <input type="checkbox"/>	DN1	
NORME ARMONIZ. HARMONIZED STD.	EN		DN2	
CLASSE DI PERDITA LEAKAGE CLASS		TIPO TYPE	Wds	bar
CLASSE FUNZIONALE FUNCTIONAL CLASS		Cg	Wdso	bar
FLUIDO GRUPPO FLUID GROUP	1	pmax	Wdsu	bar
TS	Nota 3	$^\circ\text{C}$	PS	Nota 4 bar
			PSD	Bar PT= 1.5 x PS bar

Figure 2. Label for FL Series Regulators

Note 1: See "Characteristics"

Note 2: Year of manufacture

Note 3: Class 1: $-10/60^\circ\text{C}$
 Class 2: $-20/60^\circ\text{C}$

Note 4: PN 16 PS: 16 bar
 PN 25 PS: 25 bar
 ANSI 150 PS: 19.3 bar
 ANSI 300 PS: 50 bar
 ANSI 600 PS: 100 bar

TRANSPORT AND HANDLING

Established transport and handling procedures shall be followed to avoid any damage to the pressure containing parts from shocks or anomalous stresses.

Ringbolts are designed just for handling of equipment weight. Built-up sensing lines and pressure accessories (e.g. pilots) shall be protected from shocks or anomalous stresses.

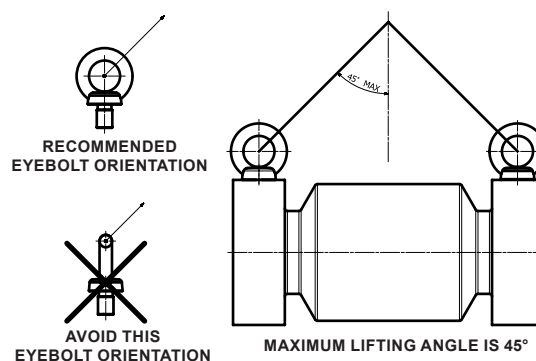

Figure 3. Lifting Lugs: Illustration of Lateral Loading

WARNING

Only qualified personnel in rigging may use lifting equipment to transport and handle this unit. If violated, personal injury and/or equipment damage may result.

To prevent personal injury or damage to the equipment during storage, installation or maintenance operations, proper supports shall be used when sitting the regulator on a flat surface to keep it from rolling.

Type FL

ATEX REQUIREMENTS

Application of ATEX Product Directive:

TYPE	CLASSIFICATION	ATEX ASSEMBLIES	ATEX LABELLING
Regulator/SSD	Non-electrical equipment	Not falling under the 2014/34/EU Directive	No
Regulator/SSD + electrical device	Non-electric equipment equipped with an electrical device falling under the scope of the ATEX Directive 2014/34/EU	Constitutes an assembly according to the 2014/34/EU Directive	CE Ex II 2 GT



WARNING

Carefully follow below instructions for the usage of "ATEX Assembly" in an explosive atmosphere.

A non-electrical equipment incorporating an electrical device (proximity, microswitch...) is an "ATEX Assembly", and in the scope of the ATEX Directive 2014/34/EU.

When such equipment(s) is used in a natural gas pressure control and/or measuring station in compliance with the following European standards: EN12186, EN12279 and EN 1776, can be installed in any type of classified zones according to the Directive 1999/92/EC dated 16 December 1999, in the following conditions:

- the equipment(s) / electrical circuit is connected to a suitable and certified intrinsically safe apparatus (suitable zener barrier)
- the equipment(s) / electrical circuit is used according to this instruction manual issued by the manufacturer and / or available on our website

DESCRIPTION

The FL Series regulators are used in reduction, distribution and conveying stations using suitably filtered natural gas.

This product has been designed to be used with fuel gases of 1st and 2nd family according to EN 437, and with other non aggressive and non fuel gases. For any other gases, other than natural gas, please contact your local sales agent.

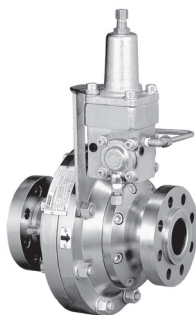

FL REGULATOR

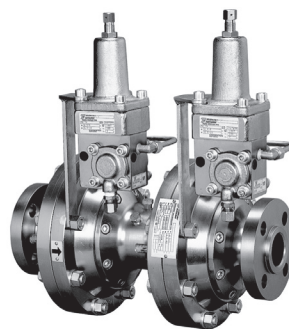

MFL REGULATOR + MONITOR

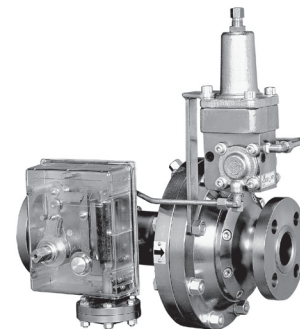

BFL REGULATOR + SLAM-SHUT

Figure 4. FL Series Configurations

Table 2. FL Series Configurations

CONFIGURATIONS	ID-ABBREVIATIONS							
	Low Pressure PN 16/25 - ANSI 150			High Pressure ANSI 300/600				
	Standard	Silenced		Standard	Silenced			
SR		SRS	SR		SRII	SRS	SRSII	
Regulator	FL-BP	FL-BP-SR	FL-BP-SRS	FL	FL-SR	FL-SRII	FL-SRS	FL-SRSII
Regulator + Monitor	MFL-BP	MFL-BP-SR	MFL-BP-SRS	MFL	MFL-SR	MFL-SRII	MFL-SRS	MFL-SRSII
Regulator + Slam-shut	BFL-BP	BFL-BP-SR	BFL-BP-SRS	BFL	BFL-SR	BFL-SRII	BFL-SRS	BFL-SRSII

Note: Types SRII and SRSII silencers are not available for DN 40 and DN 65 sizes. Sizes DN 200 and 250 are available only with SRII or SRSII silencers. SRS/SRSII silenced solutions have a widened output flange. Also available: SRS-R reinforced version; version with widened output but without a built-in silencer.

ATEX Labelling

The nameplate will be installed on the ATEX assembly.

TIPO TYPE	[]		
MATRICOLA SERIAL NR.	[]	ANNO YEAR	[]
DESTINAZIONE D'USO INTENDED USE	[]		

Where:

- Manufacturer:** Name and address and/or logo of the manufacturer
- CE:** Conformity marking to European Directive
- Type:** Description of the ATEX Assembly
- Serial Number and Year of Construction
- Ex:** Specific marking of explosion protection
- II:** Equipment group
- 2:** Equipment Category/level of protection 2 = suitable for zone 1
- G:** For gases, vapor or mists
- T:** Temperature Class (i.e.: T6 > 85 ... ≤ 100 °C)
- Intended Use:** Natural Gas infrastructures

PILOTS

The FL Series regulators are equipped with the PS/ or PRX/ Series pilots and with OS/80X or OS/80X-PN Series slam shut device.

Table 3. Pilot Type PS/ and PRX/ Characteristics

Regulator or Monitor	Application		Allowable Pressure PS (bar)	Set Range W_d (bar)	Body and Covers Material
	Operating Monitor				
	Regulator	Monitor			
PS/79-1	-	-	20	0.01 - 0.5	Aluminium
PS/79-2	-	-		0.5 - 3	
PS/79	PSO/79	REO/79	100	0.5 - 40	Steel
PS/80	PSO/80	REO/80		1.5 - 40	
PRX/120	PRX/120	PRX/125		1 - 40	
PRX-AP/120	PRX-AP/120	PRX-AP/125		30 - 80	

Note: All PS Series pilots are supplied with a filter (5 μ filtering degree) and built-in pressure stabilizer, with the exception of Types PSO/79 and PSO/80. The Type SA/2 stabilizer filter must be used with PRX Series pilots. All pilots are supplied with 1/4" NPT female threaded connections.

Table 4. Stabilizer Filter Type SA/2 Characteristics

Model	Allowable Pressure PS (bar)	Supplied Pressure	Body and Covers Material
SA/2	100	3 bar + Downstream pressure	Steel

Note: The Type SA/2 stabilizer filter is supplied with a filter (5 μ filtering degree) and is suitable for heating. Supplied with 1/4" NPT female threaded connections.

Table 5. Booster Valve Types V/31-2, PRX/131 and PRX-AP/131 Characteristics

Model	Allowable Pressure PS (bar)	Set Range W_d (bar)	Body and Covers Material
V/31-2	19	0.015 - 0.55	Aluminium
PRX/131	100	0.5 - 40	Steel
PRX-AP/131		30 - 80	

Note: Booster Valves supplied with 1/4" NPT female threaded connections

Table 6. Spring Loaded Pneumatic Slam Shut Device Type OS/80X Characteristics

Model	Servomotor Body Resistance (bar)	Overpressure Set Range W_{dc} (bar)		Underpressure Set Range W_{du} (bar)		Body Material
		Min.	Max.	Min.	Max.	
OS/80X-BP	5	0.03	2	0.01	0.60	Aluminium
OS/80X-BPA-D	20					
OS/80X-MPA-D	100	0.50	5	0.25	4	Steel
OS/80X-APA-D		2	10	0.30	7	
OS/84X		5	41	4	16	Brass
OS/88X		18	80	8	70	

Note: Slam Shut Devices supplied with 1/4" NPT female threaded connections

Table 7. Pneumatic Slam Shut Device Controlled by PRX Pilot Type OS/80X-PN Characteristics

Model	Servomotor Body Resistance (bar)	Overpressure Set Range W_{dc} (bar)		Underpressure Set Range W_{du} (bar)		Body Material
		Min.	Max.	Min.	Max.	
OS/80X-PN	100	0.5	40	0.5	40	Steel
OS/84X-PN	100	30	80	30	80	Brass

OS/80X-PN: Pressure range 0.5 to 40 bar

Appliance made of an OS/80X-APA-D set at about 0.4 bar and a variable number of PRX/182-PN pilots for overpressure and PRX/181-PN for underpressure, as many as necessary to control different points of the installation.

OS/84X-PN (Safety accessory): Pressure range 30 to 80 bar

Appliance made of an OS/84X set at about 20 bar and a variable number of PRX-AP/182-PN pilots for overpressure and PRX-AP/181-PN for underpressure, as many as necessary to control different points of the installation.

Note: Slam Shut Device supplied with 1/4" NPT female threaded connections

Type FL

DIMENSIONS AND WEIGHTS

STANDARD AND TYPE SR VERSIONS

FL-BP

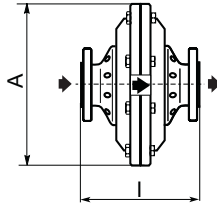

MFL-BP

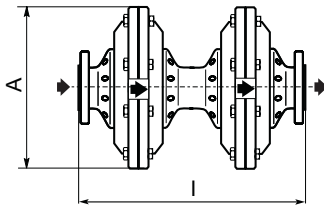

BFL-BP

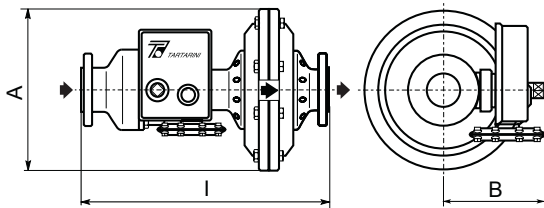

WIDENED OUTLET AND TYPE SRS VERSIONS

FL-BP

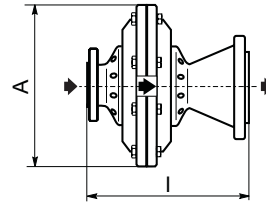

MFL-BP

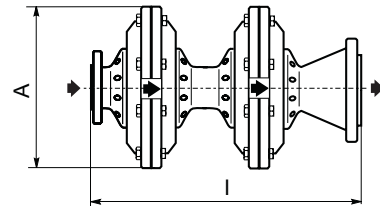

BFL-BP

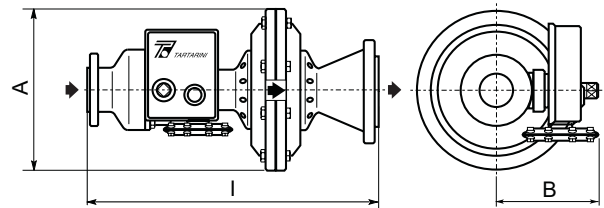

Figure 5. Type FL-BP Series Dimensions

Table 8. Type FL-BP Series Dimensions

DN	FACE TO FACE - I (mm)			DIMENSIONS (mm)	
	PN 16 - ANSI 150			A	B
	FL-BP	MFL-BP	BFL-BP		
25	184	360	355	285	199
40	222	424	410	306	206
50	254	510	485	335	213
65	276	542	530	370	227
80	298	564	560	400	245
100	352	675	670	450	269
150	451	-	-	590	-
200	543	-	-	653	-
250	730	-	-	785	-

DN	FACE TO FACE - I (mm)			DIMENSIONS (mm)	
	PN 16 - ANSI 150			A	B
	FL-BP	MFL-BP	BFL-BP		
25x100	290	466	461	285	199
40x150	350	552	538	306	206
50x150	380	636	611	335	213
65x200	420	686	674	370	227
80x250	470	736	732	400	245
100x250	525	848	843	450	269
150x300	630	-	-	590	-

Threaded 1/4" NPT female impulse connections.

Table 9. Type FL-BP Series Weights

DN	STANDARD AND SR VERSION WEIGHTS (kg)		
	PN 16 - ANSI 150		
	FL-BP	MFL-BP	BFL-BP
25	24	48	38
40	37	77	50
50	48	97	60
65	68	140	100
80	83	168	132
100	105	239	197
150	255	-	-
200	620	-	-
250	1190	-	-

DN	WIDENED OUTLET AND SRS VERSION WEIGHTS (kg)		
	PN 16 - ANSI 150		
	FL-BP	MFL-BP	BFL-BP
25x100	30	54	44
40x150	47	87	60
50x150	58	107	70
65x200	90	162	122
80x250	128	213	177
100x250	150	284	242
150x300	380	-	-

DIMENSIONS AND WEIGHTS

STANDARD AND TYPE SR/SRII VERSIONS

WIDENED OUTLET AND TYPE SRS/SRSII VERSIONS

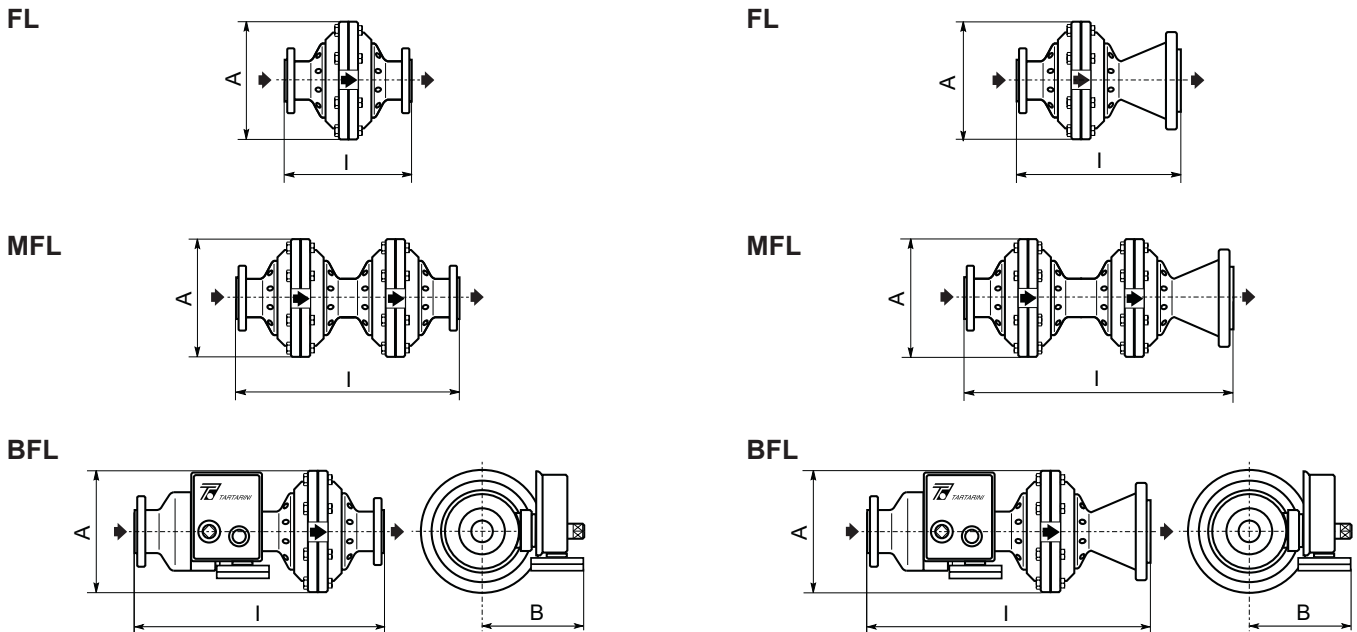

Figure 6. Type FL Series Dimensions

Table 10. Type FL Series Dimensions

DN	FACE TO FACE - I (mm)			DIMENSIONS (mm)	
	ANSI 300 - ANSI 600			A	B
	FL	MFL	BFL		
25	210	385	390	225	199
40	251	450	445	265	206
50	286	535	515	287	213
65	311	574	560	355	227
80	337	600	600	400	245
100	394	720	710	480	269
150	508	-	910	610	330
200	610	-	-	653	-
250	752	-	-	785	-

N.B.: For DN 200 ANSI 300 face to face is 568 mm, for DN 250 ANSI 300 face to face is 708 mm.

DN	FACE TO FACE - I (mm)			DIMENSIONS (mm)	
	ANSI 300 - ANSI 600			A	B
	FL	MFL	BFL		
25x100	300	475	480	225	199
40x150	370	569	564	265	206
50x150	400	649	629	287	213
65x200	440	703	689	355	227
80x250	500	763	763	400	245
100x250	525	851	841	480	269
150x300	660	-	-	610	-
200x400	750	-	-	653	-
250x500	965.5	-	-	785	-

Note: SRS-R reinforced version is available up to DN 100, add 14 mm to face to face dimension. For DN 200x400 ANSI 300 face to face is 722 mm, for DN 250x500 ANSI 300 face to face is 943 mm.

Threaded 1/4" NPT female impulse connections.

Table 11. Type FL Series Weights

STANDARD AND SR/SRII VERSION WEIGHTS (kg)			
DN	ANSI 300 - ANSI 600		
	FL	MFL	BFL
25	31	73	49
40	47	96	71
50	60	113	90
65	88	174	129
80	148	296	208
100	201	364	297
150	480	-	760
200	620	-	-
250	1190	-	-

WIDENED OUTLET AND SRS/SRSII VERSION WEIGHTS (kg)			
DN	ANSI 300 - ANSI 600		
	FL	MFL	BFL
25x100	45	87	63
40x150	74	123	98
50x150	87	140	117
65x200	135	220	176
80x250	233	380	293
100x250	286	450	382
150x300	620	-	-
200x400	900	-	-
250x500	1623	-	-

Type FL

OPERATION

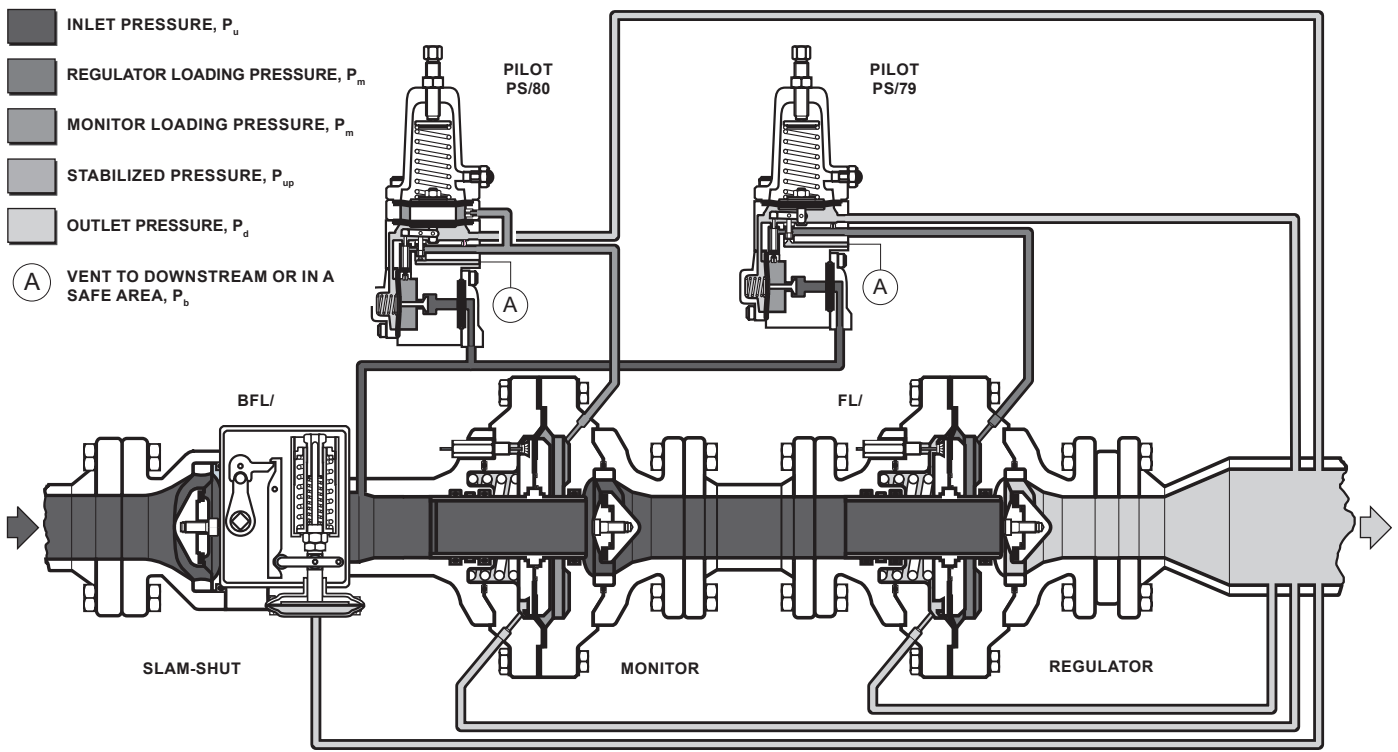

Figure 7. Types BFL and FL Operational Schematic

Regulator

The Diaphragm Unit (assembled to the shutter) divides the regulator control head into two chambers.

One of the chambers is connected to regulated outlet pressure (P_d), and the other to loading pressure (P_m) produced by the pilot according to pressure downstream.

Due to reduced loading pressure, the regulator spring acts on the diaphragm unit and closes the shutter.

The shutter moves to an open position when the force produced by loading pressure (P_m) acting on the diaphragm unit becomes greater than the force produced by downstream regulated outlet pressure (P_d) added to the load of the regulator spring. The shutter stays idle when the two forces are equal, under these conditions, downstream pressure is equal to the system's set value.

Any change in requested flow-rate produces a variation in downstream regulated outlet pressure and the regulator, controlled by the pilot, opens or closes to deliver the requested flow-rate while keeping downstream pressure stable.

Monitor

The Monitor or emergency regulator is used as a safety device in gas pressure reduction systems. The purpose of this device is to protect the system against possible

overpressure, while keeping the downstream line in service. The monitor controls downstream pressure at the same point as the main regulator and is set a little higher than the latter.

Under normal operation, the monitor is fully open as it detects a pressure value lower than its set value. If downstream pressure increases and exceeds the monitor set point, the monitor comes into operation and adjusts pressure to its own set value.

Slam-shut Device

The slam-shut device has a shutter and individual seat. It functions independently of the regulator/monitor. The shutter can only be hand-opened, by rotating the slam-shut reset shaft counter clockwise. To keep the shutter open, the slam-shut controller Series OS/80X or OS/80X-PN is used. Both series are designed to operate on maximum and minimum, maximum only, or minimum only pressure.

When the system's downstream pressure is at normal operating value, the slam-shut controller remains set and prevents the slam-shut reset shaft from turning by keeping the slam-shut shutter open.

When downstream pressure varies beyond its set limits, the slam-shut controller releases the reset shaft and the shutter is closed by the thrust of the spring.

INSTALLATION

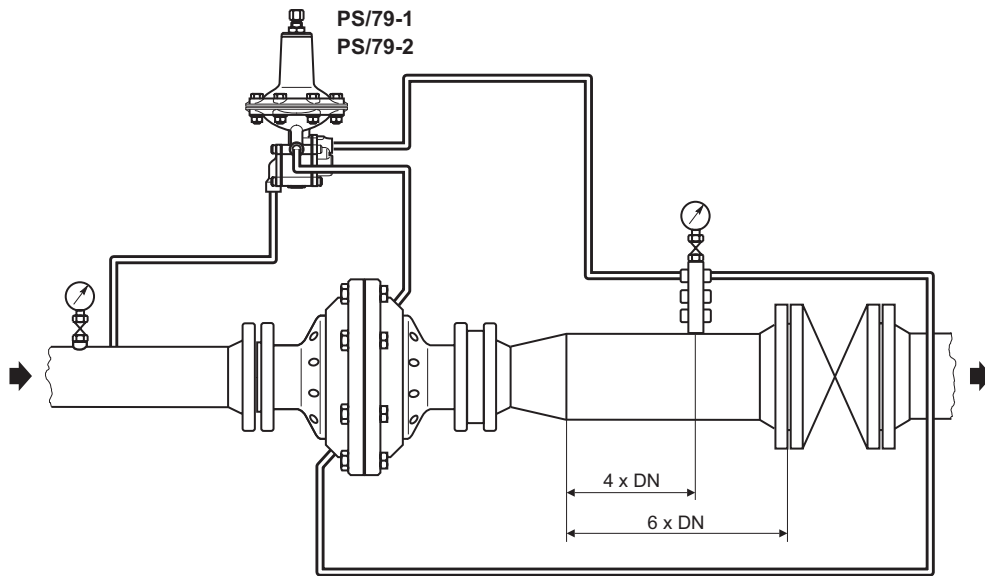

TYPE FL-BP REGULATOR WITH PILOT PS/79-1-2

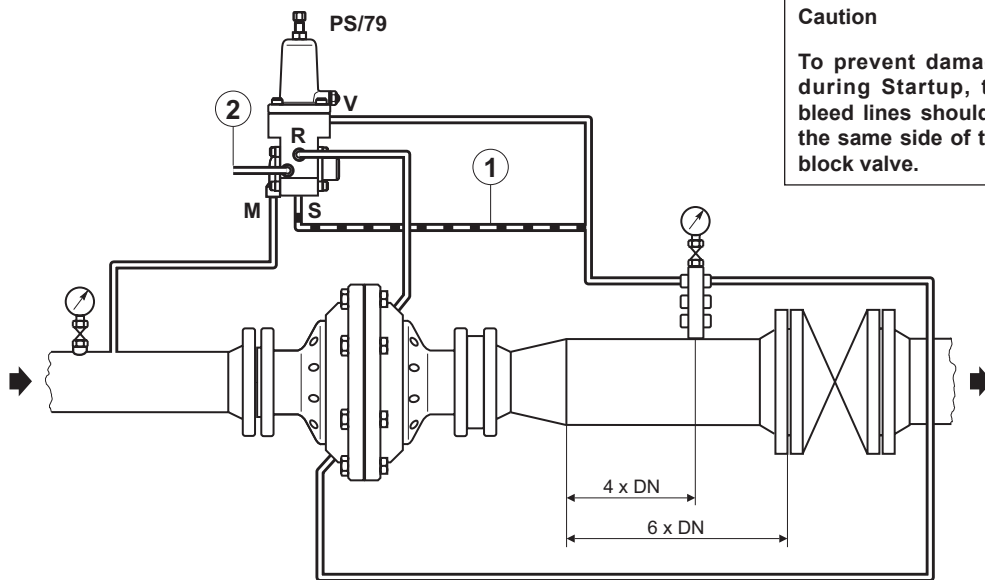

Caution
To prevent damage to the pilot during Startup, the sense and bleed lines should be located on the same side of the downstream block valve.

TYPE FL REGULATOR WITH PILOT PS/79

LEGEND:

- | | | |
|-------------------------------------|---------------------------------------|-------------------------------|
| ① VENT DOWNSTREAM OR TO A SAFE AREA | M UPSTREAM OF THE REGULATOR | S DOWNSTREAM OR SAFE AREA |
| ② TO THE HEATING | R TO THE REGULATOR (LOADING PRESSURE) | V DOWNSTREAM OF THE REGULATOR |

NOTE: RECOMMENDED PIPING IS STAINLESS STEEL WITH 10 mm DIAMETER.

Figure 8. FL Series DN 25 to DN 200 Connection/Installation Schematics

Type FL

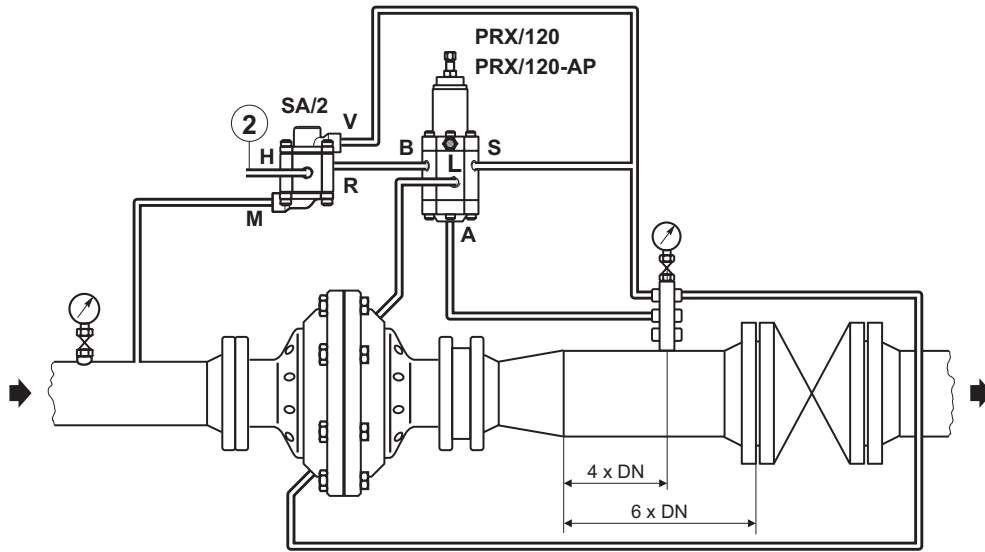

TYPE FL REGULATOR WITH PILOT PRX/120 OR PRX/120-AP

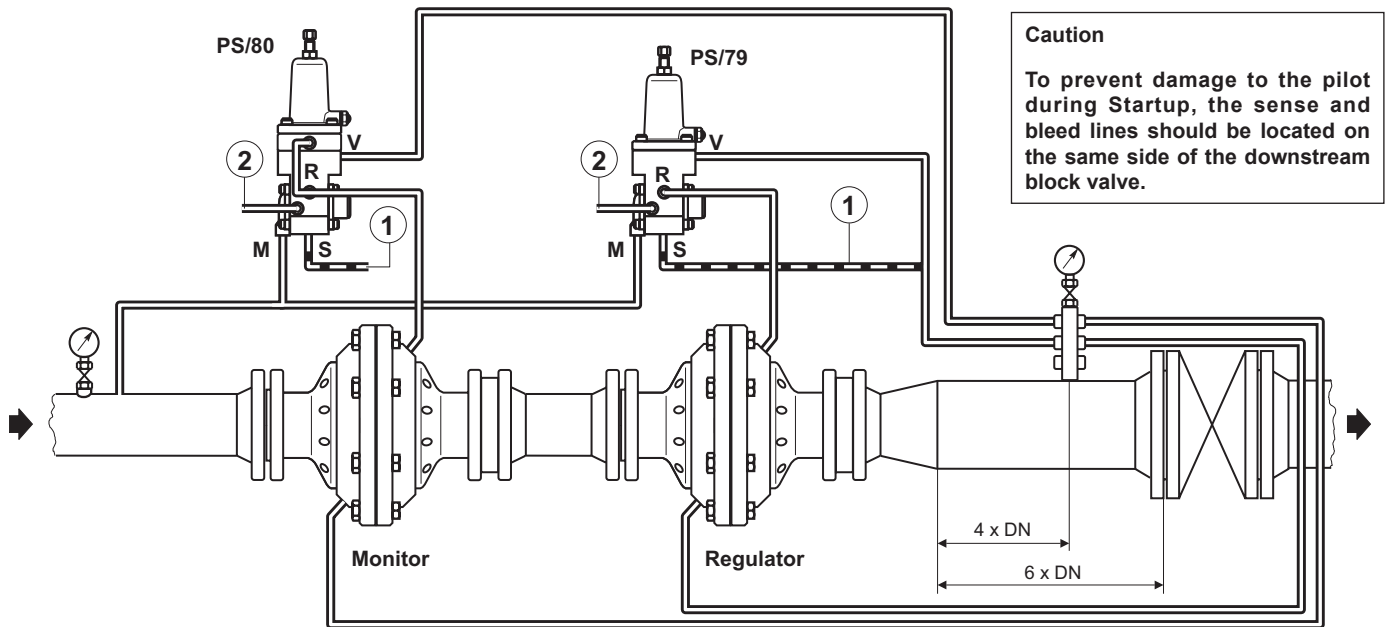

TYPE FL REGULATOR AND MONITOR WITH PILOT PS/79 AND PS/80

LEGEND:

- | | | |
|-------------------------------------|---------------------------------------|--|
| ① VENT DOWNSTREAM OR TO A SAFE AREA | B PILOT FEED | R FOR PS/79/80 - TO THE REGULATOR (LOADING PRESSURE)
FOR SA/2 - TO THE PILOT FEED |
| ② TO THE HEATING | H WATER INLET/OUTLET | S DOWNSTREAM OR SAFE AREA |
| A DOWNSTREAM OF THE REGULATOR | L TO THE REGULATOR (LOADING PRESSURE) | V DOWNSTREAM OF THE REGULATOR |
| | M UPSTREAM OF THE REGULATOR | |

NOTE: RECOMMENDED PIPING IS STAINLESS STEEL WITH 10 mm DIAMETER.

Figure 8. FL Series DN 25 to DN 200 Connection/Installation Schematics (continued)

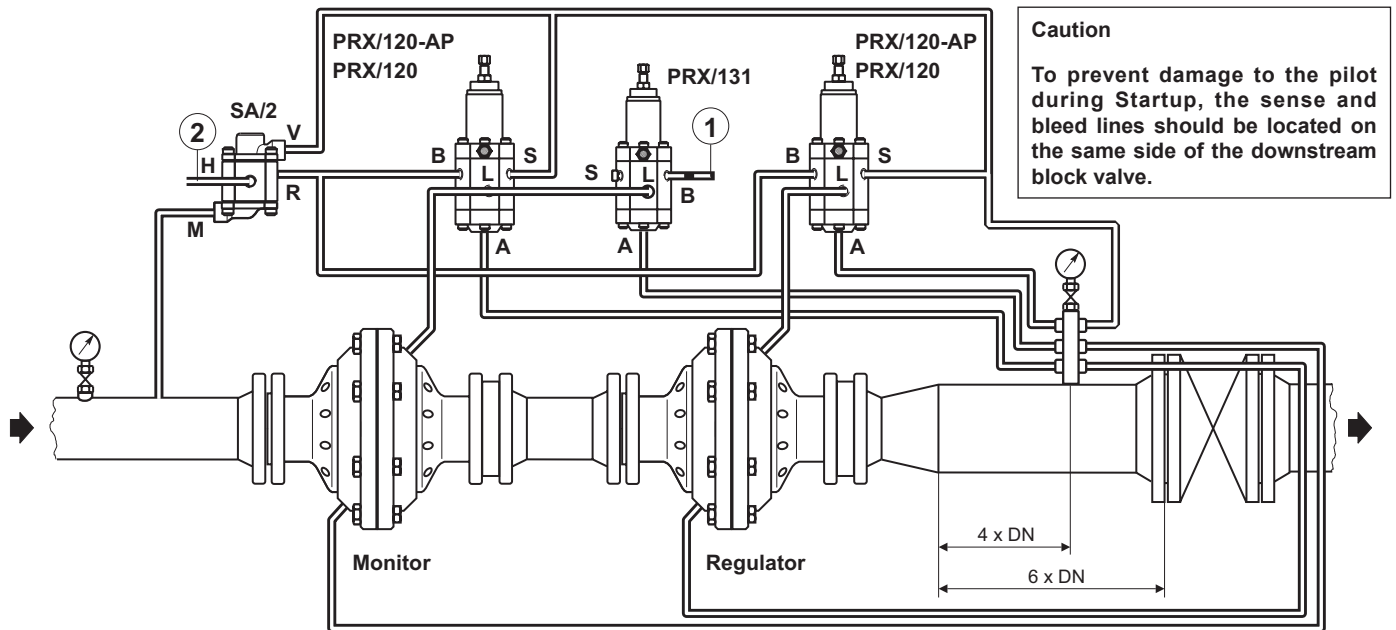

TYPE FL REGULATOR AND MONITOR WITH PILOT PRX/120 AND BOOSTER VALVE PRX/131

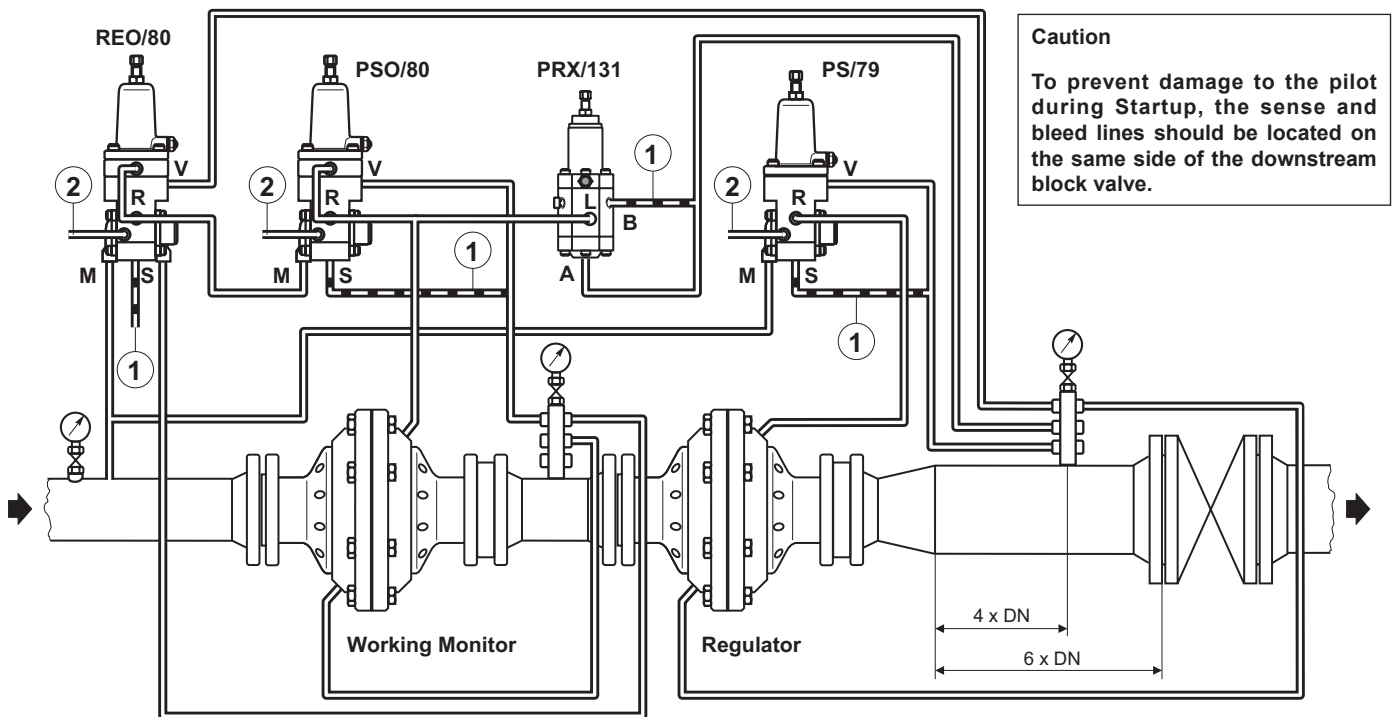

TYPE FL REGULATOR AND WORKING MONITOR WITH PILOT PS/79, PSO/80, REO/80 AND BOOSTER VALVE PRX/131

LEGEND:

- | | | |
|-------------------------------------|--|--|
| ① VENT DOWNSTREAM OR TO A SAFE AREA | B FOR PRX/120 - PILOT FEED
FOR PRX131 - DOWNSTREAM OR SAFE AREA | M UPSTREAM OF THE REGULATOR |
| ② TO THE HEATING | H WATER INLET/OUTLET | R FOR PS/79/80 - TO THE REGULATOR (LOADING PRESSURE)
FOR SA/2 - TO THE PILOT FEED |
| A DOWNSTREAM OF THE REGULATOR | L TO THE REGULATOR (LOADING PRESSURE) | S DOWNSTREAM OR SAFE AREA |
| | | V DOWNSTREAM OF THE REGULATOR |

NOTE: RECOMMENDED PIPING IS STAINLESS STEEL WITH 10 mm DIAMETER.

Figure 8. FL Series DN 25 to DN 200 Connection/Installation Schematics (continued)

Type FL

Caution

To prevent damage to the pilot during Startup, the sense and bleed lines should be located on the same side of the downstream block valve.

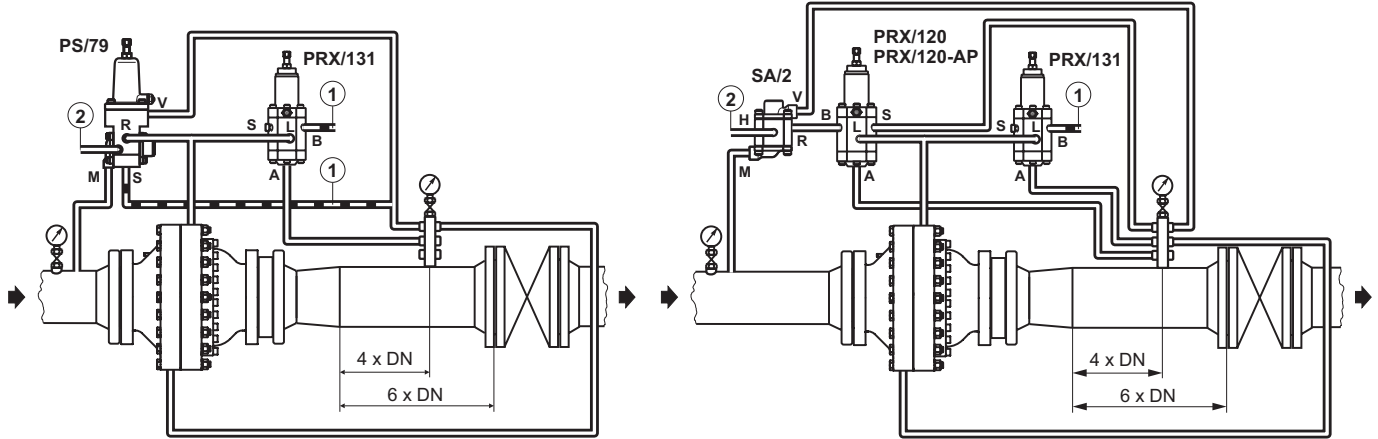

TYPE FL DN 250 REGULATOR WITH PILOT PS/79 AND BOOSTER VALVE PRX/131

TYPE FL DN 250 REGULATOR WITH PILOT PRX/120 OR PRX/120-AP AND BOOSTER VALVE PRX/131

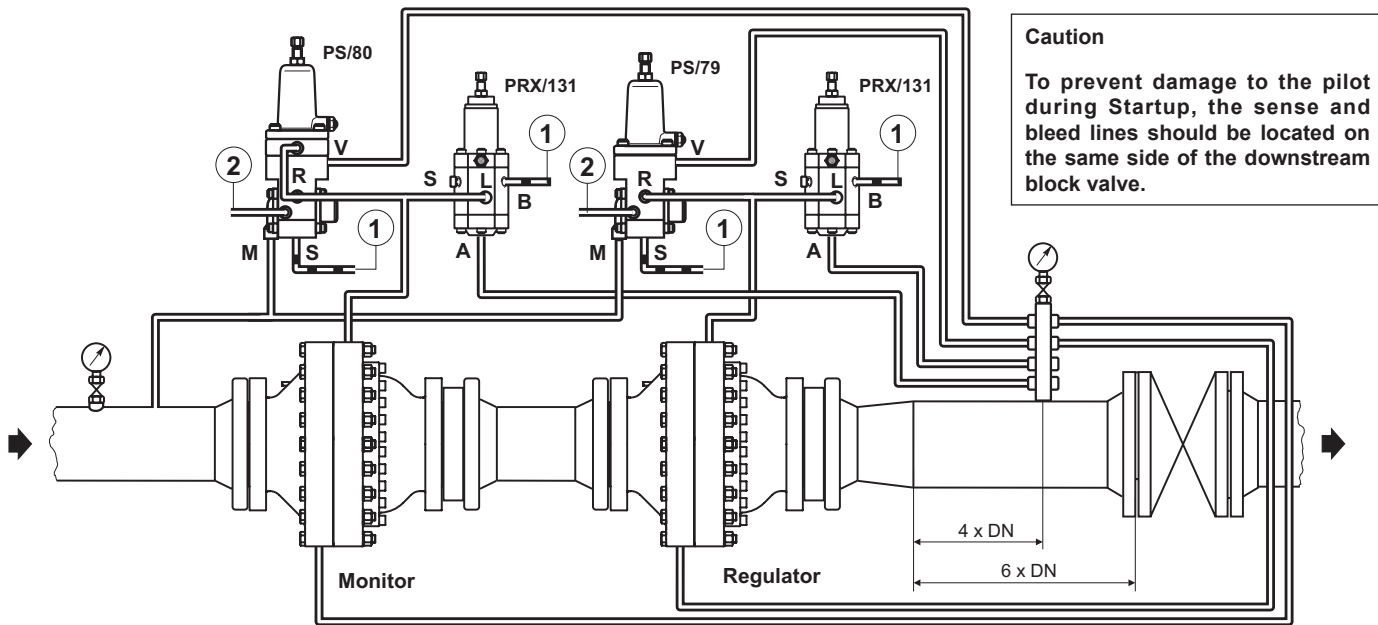

Caution

To prevent damage to the pilot during Startup, the sense and bleed lines should be located on the same side of the downstream block valve.

TYPE FL DN 250 REGULATOR WITH PILOT PS/79 AND BOOSTER VALVE PRX/131, MONITOR WITH PILOT PS/80 AND BOOSTER VALVE PRX/131

LEGEND:

- | | | |
|-------------------------------------|---|--|
| ① VENT DOWNSTREAM OR TO A SAFE AREA | B FOR PRX/120 - PILOT FEED
FOR PRX/131 - DOWNSTREAM OR SAFE AREA | M UPSTREAM OF THE REGULATOR |
| ② TO THE HEATING | H WATER INLET/OUTLET | R FOR PS/79/80 - TO THE REGULATOR (LOADING PRESSURE)
FOR SA/2 - TO THE PILOT FEED |
| A DOWNSTREAM OF THE REGULATOR | L TO THE REGULATOR (LOADING PRESSURE) | S DOWNSTREAM OR SAFE AREA |
| | | V DOWNSTREAM OF THE REGULATOR |

NOTE: RECOMMENDED PIPING IS STAINLESS STEEL WITH 10 mm DIAMETER.

Figure 9. Type FL DN 250 Connection/Installation Schematics

INSTALLATION (continued)

- Ensure that the data found on the regulator plate are compatible with usage requirements.
- Ensure that the regulator is mounted in accordance with the direction of flow indicated by the arrow.
- Make the connections as indicated in Figures 7 and 8.



WARNING

Only qualified personnel should install or service a regulator. Regulators should be installed, operated and maintained in accordance with international and applicable codes and regulations.

If the regulator vents fluid or a leak develops in the system, it indicates that servicing is required. Failure to take the regulator out of service immediately may create a hazardous condition.

Personal injury, equipment damage, or leakage due to escaping fluid or bursting of pressure-containing parts may result if this regulator is over pressured or is installed where service conditions could exceed the limits given in the “Characteristics” section, or where conditions exceed any ratings of the adjacent piping or piping connections.

To avoid such injury or damage, provide pressure-relieving or pressure-limiting devices (as required by the appropriate code, regulation, or standard) to prevent service conditions from exceeding limits. Additionally, physical damage to the regulator could result in personal injury and property damage due to escaping fluid. To avoid such injury and damage, install the regulator in a safe location.

Before installation, check if service conditions are consistent with usage limitations and if pilot set-up or possible built-in safety slam-shut device, is in accordance with service conditions of protected equipment. All means for venting must be provided in assemblies where the pressure equipment is installed (ENs 12186 and 12279). All means for draining must be provided for any equipment installed before regulators and slam-shut devices (ENs 12186 and 12279).

According to EN 12186 and 12279, where this product is used:

- Provide cathodic protection and electrical isolation to avoid any corrosion;
- In accordance with clause 7.3/7.2 of aforesaid standards, the gas shall be cleaned by proper filters / separators / scrubbers to avoid any technical and reasonable hazard of erosion or abrasion for pressure containing parts.

All pressure equipment should be installed in a non-seismic area; should not be exposed to fire; and should be protected from thunderbolt (lightening) strikes. All pipelines should be cleaned before installation of the regulator. Before installing the regulator, check that the regulator has not been damaged or contains foreign material after shipment. Use suitable line gaskets and approved piping and bolting practices.

Install the regulator in a horizontal position, and check that flow through the body is in the direction indicated by the arrow on the body. Installation must be performed avoiding to create pressure force on the body and using suitable joint means according to equipment dimensions and service conditions. The user should check and carry out any protection suitable for assembly’s specific environment.



WARNING

The regulator and pilot must be installed so that the vent hole in the pilot spring case is unobstructed at all times. An obstructed vent can result in loss of pressure regulation resulting in equipment damage, fires and/or explosion and personal injury.

For outdoor installations, the regulator should be located away from vehicular traffic and positioned so that water, ice, and other foreign materials cannot enter the spring case through the vent.

Avoid placing the regulator beneath eaves or downspouts, and be sure it is above the probable snow level.

STARTUP OF THE REGULATOR

Preliminary Notes:

The regulator and possible built-in slam-shut device is factory set at approximately the midpoint of the spring range or the pressure requested, so an initial adjustment may be required to obtain desired setpoint after point c.

Setup of any further device upstream and downstream of the regulator (shut-off, monitor, relief, etc.) shall be managed by customized installation instruction according to the specific application.

Let the filtered, and if necessary preheated, gas reach the regulator during service life.

Procedure:

- Slightly open the downstream line valve
- Just slightly and very slowly open the upstream valve.
- Wait until the downstream pressure is stabilized.
- Finish opening the upstream and downstream valves slowly.

Type FL

PILOT ADJUSTMENT

To change the regulator outlet pressure, turn the pilot adjusting screw clockwise to increase pressure or counter clockwise to decrease pressure.

To change the slam-shut setpoints (overpressure and/or underpressure), remove the spring closing cap of the pilot and turn the adjusting screws clockwise to increase outlet pressure or counter clockwise to decrease pressure.

Monitor the outlet pressure with a test gauge during the adjustment.

SHUTDOWN

CAUTION

If the pilot bleed control line pressure is shut down first, the downstream system may be subjected to full inlet pressure.

- a. If the pilot setting must be disturbed, be sure to keep some tension on the spring. This will prevent trapping inlet pressure during blow down.
- b. Slowly close the valves in the following order:
 1. Inlet block valve
 2. Outlet block valve

PERIODICAL CHECKS

CAUTION

It is recommended that the regulator, pilots and slam-shut devices be periodically inspected and tested for proper operation, set point and operation of any overpressure protection device.

Slowly close the On-Off valve located downstream and check the pressure in the line section between the regulator and the valve. Some increase in the downstream pressure should be observed as the regulator goes into no flow condition created by closing the downstream On-Off valve.

The pressure will then stabilize. If a steady increase in the downstream pressure occurs, this is a clear sign that the unit is not closing pressure tight.

Check whether the leakage is due to the regulator or the pilot and then proceed with maintenance as required.

REGULATOR MAINTENANCE (SEE FIGURES 10 TO 21)

WARNING

To avoid personal injury or property damage:

- **Only qualified personnel should install, service or perform maintenance on a regulator, the pilots or accessories.**
- **If necessary, contact our technical support representatives or our authorized dealers for additional information.**

- **Before attempting disassembly of the regulator, pilots or control lines, isolate the regulator from all pressure.**
- **Release all pressure trapped within the regulator, pilots and control lines.**
- **After regulator, pilot and control line maintenance, disassembly or repair, test the equipment for external and internal tightness according to applicable codes.**
- **Use an appropriate leak detect solution to test for any leakage in the equipment.**
- **Use proper lifting techniques, when performing maintenance. Components can weigh more than 100 lbs / 45 kg.**

The regulator and its pressure accessories are subject to normal wear and must be inspected periodically and replaced if necessary.

The frequency of inspection/checks and replacement depends upon the severity of service conditions and according to applicable National or Industry codes, standards and regulations/recommendations.

In accordance with applicable National or Industry codes, standards and regulations/recommendations, all hazards covered by specific tests after final assembling before applying the CE marking, shall be covered also after every subsequent reassembly at installation site, in order to ensure that the equipment will be functional throughout its intended life.

Before proceeding with any maintenance work, shutoff the gas upstream and downstream from the regulator following the procedures in the Shutdown section, also ensure that there is no gas pressure inside the body by loosening the upstream and downstream connections.

Upon completion, check for leaks using an appropriate leak detection solution.

Replacing Seal Pad

- a. See Figure 9. Remove spacer (key 24). If no spacer was used during installation, disconnect all fittings preventing removal of outlet stub pipe and take the latter off.
- b. Loosen screws (key 5) and slide out outlet flange (key 22 or 200 for the widened outlet and SRS versions), replace O-ring (key 18).
- c. See Figure 9 and 10. Remove pad holder (key 19) from the outlet cover (key 13). For the DN 200 and 250 sizes, see figures 11, 20 and 13, the pad holder remains attached to the outlet flange and no dismantling is necessary.
- d. Loosen screw (key 25), pad retainer (key 21), remove and replace pad unit (key 20).
- e. Check that the part of sleeve (key 16) that touches pad unit (key 20) is intact. If not, refer to the General Maintenance section and replace the sleeve.
- f. Reassemble by reversing the above sequence, applying Loctite 243 or equivalent on screw (key 25). Be careful not to damage O-ring (key 18). To facilitate reassembly of pad holder (key 19), use an air pump that, when connected to fitting (key 17), causes sleeve (key 16) to open fully.

FL and MFL Regulator General Maintenance

- a. Disconnect all fittings, remove regulator from the line and place it in upward vertical position.

- b. Mark the position of inlet and outlet flanges (keys 1 and 22 or 200 for the widened outlet and SRS versions) and cover (keys 11 and 13) to keep the correct alignment during the following reassembly phase.

Only for DN 250 size mark the position of inlet and outlet flanges (keys 1 and 22) and outlet cover (key 13).



WARNING

Spring (key 6) is compressed between covers (keys 11 and 13) or between inlet flange and outlet cover (keys 1 and 13) for the DN 250 size; the sudden release of spring force could cause the casings and diaphragm/sleeve assembly to dangerously fly apart potentially causing personal injury.

To prevent this, replace two opposite positioned screws (key 9) with threaded rods and their nuts, remove the remaining screws and use nuts on the two threaded rods to slowly release spring tension.

- c. Separate covers (keys 11 and 13) by removing screws (key 9). Only for DN 250 size separate the inlet flange (key 1) and outlet cover (key 13) by removing screws (key 9).
- d. Slide sleeve-diaphragm assembly (keys 16 and 10) out of inlet cover (key 11 or inlet flange key 1 for the DN 250 size) and remove indicator (key 34).
- e. Loosen screws (key 27), axially slide out of sleeve (key 16) plates (keys 8 and 12) and diaphragm (key 10). Replace O-rings (keys 26 and 28).
- f. Loosen screws (key 5 or 64 for DN 150 and DN 200 sizes) and dismount inlet flange (key 1). Replace anti-friction rings (key 2) and O-ring (key 3).

Unit Produced Until 2013

- g. Unscrew plastic cap (key 40) from travel indicator.
- h. Unscrew the support (key 36) from inlet cover (key 11). Remove bushing (key 38) and O-ring (keys 35 and 37). Replace and lubricate the O-rings.
- i. Check indicator stem (key 34) and spring collet (key 33) previously removed, replace parts if necessary.

Unit Produced Since 2014

- g. Unscrew plastic cap (key 40) from travel indicator.
- h. Unscrew support (key 36) from inlet cover (key 11). Remove bushing (key 38) and O-ring (key 35). Remove O-ring (key 37) and backup rings (key 271). Replace and lubricate O-rings and backup rings if necessary.
- i. Check indicator stem (key 34) and spring collet (key 33) previously removed, replace parts if worn or damaged.
- j. Replace O-ring (key 4) on the cover (key 11). The O-ring (key 4) is not used in DN 250 size.
- k. Loosen screws (key 5) and axially slide out outlet flange (key 22 or 200 for the widened outlet and SRS versions). Replace O-ring (key 18), anti-friction rings (key 2) and O-ring (key 3).
- l. Remove pad holder (key 19) from the outlet cover (key 13). For the DN 200 and 250 sizes the pad holder remains attached to the outlet flange and no dismounting is necessary.

- m. Loosen screw (key 25), pad retainer (key 21), remove and replace pad unit (key 20). If present replace the O-ring (keys 46 and 47).
- n. Check that the seating surface of sleeve (key 16) that touches pad unit (key 20) is not damaged. If damage to the seating surface is observed, replace the sleeve.
- o. Check all moving parts, paying special attention to nickel plated surfaces. Replace any that are worn or damaged.
- p. Clean all stripped-down metal parts with petrol and dry with compressed air.

Reassembly

Lubricate all seals with MOLYKOTE 55 M, being very careful not to damage them when reassembling. Reassemble the parts by reversing the above steps, applying Loctite 243 or equivalent on screw (key 25). As you proceed, make sure that parts move freely and without friction. Before fitting sleeve-diaphragm assembly (key 16 and 10), recompose indicator group.

Unit Produced Until 2013

- a. Insert indicator (key 34) in support (key 36). Lubricate O-ring (key 37) and mount on indicator (key 34). Slide the bushing (key 38) on indicator and firmly tighten on the support.

Unit Produced Since 2014

- a. Insert indicator (key 34) in support (key 36). Lubricate O-ring (key 37) and backup rings (key 271). Insert the first backup ring on indicator followed by O-ring and then the other backup ring, be careful to place them correctly in the support groove (key 36). Slide the bushing (key 38) on indicator and firmly tighten on the support.
- b. Lubricate O-ring (key 35) and mount on support. Mount indicator group on inlet cover (key 11). Attach spring collet (key 33) to plate (key 8) upon completion of reassembly. Step (a.) is not required for the DN 200 and DN 250 sizes.
- c. Complete reassembly and make sure to tighten all screws uniformly.
- d. Tap indicator (key 34) with a rubber or wooden hammer so as to couple spring collet (key 33) and plate (key 8). Reassemble plastic cap (key 40).
For DN 200 and 250 sizes insert indicator (key 34) and hook it to plate (key 8), reassemble indicator group as indicated above and mount it on inlet cover (key 11 or inlet flange key 1 for the DN 250 size).
- e. Use an air pump connected to fitting (key 7) to check proper regulator working order.
- f. After the reassembly completion, check the proper functioning of all parts. Check the regulator with soapy water, making sure there are no leaks.
- g. Remount regulator on the line and reestablish all connections.

MFL and MFL-BP Versions

The MFL/ configuration consists of two FL/ and the MFLBP/ of two FL-BP/ regulators; in each the inlet regulator acts as a monitor and the outlet as a regulator proper.

Monitor outlet flange and regulator inlet flange are one-piece the stub pipe (key 41), see figure 16.

For the maintenance procedures see previous paragraphs.

BFL Regulator and Slam-shut General Maintenance (See Figure 22)

- a. Disconnect all fittings, remove regulator from the line and place it in upward vertical position.
- b. Mark the position of outlet flanges (key 22 or 200 for the widened outlet and SRS versions) among cover (key 13), of the inlet flange (key 100) among stub pipe (key 190) and of the stub pipe (key 190) among cover (key 11), to keep the correct alignment during the following reassembly phase.



WARNING

Spring (key 6) is compressed between covers (keys 11 and 13); the sudden release of spring force could cause the casings and diaphragm/sleeve assembly to dangerously fly apart potentially causing personal injury.

To prevent this, replace two opposite positioned screws (key 9) with threaded rods and their nuts, remove the remaining screws and use nuts on the two threaded rods to slowly release spring tension.

- c. Separate covers (keys 11 and 13) by removing screws (key 9).
- d. Slide sleeve-diaphragm assembly (key 16 and 10) out of inlet cover (key 11) and remove indicator (key 34).
- e. Loosen screws (key 27), axially slide out of sleeve (key 16) plates (key 8 and 12) and diaphragm (key 10). Replace O-rings (key 26 and 28).
- f. Loosen screws (key 5) and dismount stub pipe (key 190).

Unit Produced Until 2013

- g. Unscrew plastic cap (key 40) from travel indicator.
- h. Unscrew the support (key 36) from inlet cover (key 11). Remove bushing (key 38) and O-ring (key 35 and 37). Replace and lubricate the O-rings.
- i. Check indicator stem (key 34) and spring collet (key 33) previously removed, replace parts if necessary.

Unit Produced Since 2014

- g. Unscrew plastic cap (key 40) from travel indicator.
- h. Unscrew support (key 36) from inlet cover (key 11). Remove bushing (key 38) and O-ring (key 35). Remove O-ring (key 37) and backup rings (key 271). Replace and lubricate O-rings and backup rings if necessary.
- i. Check indicator stem (key 34) and spring collet (key 33) previously removed, replace parts if worn or damaged.

- j. Replace O-ring (key 4) on the cover (key 11).
- k. Loosen screws (key 5) and axially slide out outlet flange (key 22 or 200 for the widened outlet and SRS versions). Replace O-ring (key 18), anti-friction rings (key 2) and O-ring (key 3).
- l. Remove pad holder (key 19) from the outlet cover (key 3).
- m. Loosen screw (key 25), pad retainer (key 21), remove and replace pad unit (key 20).

- n. Check that the seating surface of sleeve (key 16) that touches pad unit (key 20) is not damaged. If damage to the seating surface is observed, replace the sleeve.
- o. Invert stub pipe (key 190) and slam-shut using the inlet flange (key 100) as a support.
- p. Loosen the special screws (key 133) and dismount the slam-shut controller.
- q. Loosen screws (key 135) and remove hub (key 124). Remove elastic ring (key 122) and dismount parts. Replace O-rings (keys 120, 125 and 126) and anti-friction rings (key 119). Check bearing (key 128) and replace it if is necessary.
- r. Slowly loosen nuts (key 112) to slowly release spring (key 114) tension (key 114).
- s. Remove sleeve (key 117), disk (key 110) and pad holder (key 19), loosen screw (key 25) and replace pad unit (key 20). Replace O-ring (key 107), for DN 65 to DN 150 sizes replace also (key 47).
- t. Replace O-ring (key 115), anti-friction rings (key 2) and O-rings (key 3).
- u. Check all moving parts, paying special attention to nickel plated surfaces. Replace any that are worn or damaged.
- v. Clean all stripped-down metal parts with petrol and dry with compressed air.

Reassembly

Lubricate all seals with MOLYKOTE 55 M, being very careful not to damage them when reassembling, Reassemble the parts by reversing the above steps, applying Loctite 243 or equivalent on screw (key 25). As you proceed, make sure that parts move freely and without friction. Before fitting sleeve-diaphragm assembly (keys 16 and 10), recompose indicator group.

Unit Produced Until 2013

- a. Insert indicator (key 34) in support (key 36). Lubricate O-ring (key 37) and mount on indicator (key 34). Slide the bushing (key 38) on indicator and firmly tighten on the support.

Unit Produced Since 2014

- a. Insert indicator (key 34) in support (key 36). Lubricate O-ring (key 37) and backup rings (key 271). Insert the first backup ring on indicator followed by O-ring and then the other backup ring, be careful to place them correctly in the support groove (key 36). Slide the bushing (key 38) on indicator and firmly tighten on the support.

- b. Lubricate O-ring (key 35) and mount on support. Mount indicator group on inlet cover (key 11). Attach spring collet (key 33) to plate (key 8) upon completion of reassembly. Step (a.) is not required for the DN 200 and DN 250 sizes.
- c. Complete reassembly and make sure to tighten all screws uniformly.
- d. Tap indicator (key 34) with a rubber or wooden hammer so as to couple spring collet (key 33) and plate (key 8). Reassemble plastic cap (key 40).
- e. Use an air pump connected to fitting (key 7) to check proper regulator working order.
- f. When reassembling the hub (key 124), make sure that the pawl of shaft unit (key 121) is facing the inlet flange (key 100).

- g. Check that slam-shut sleeve (key 117) opens when shaft unit (key 121) is rotated anticlockwise.
- h. Before reassembling the slam-shut controller, make sure that the pawl of shaft unit (key 121) is against the sleeve (key 117). Upon completion of the assembling procedure, check that slam-shut controller has been correctly mounted.
- i. After the reassembly completion, check the proper functioning of all parts. Check the regulator with soapy water, making sure there are no leaks.
- j. Remount regulator on the line and reestablish connections.

SLAM-SHUT CONTROLLER MAINTENANCE OS/80X SERIES (SEE FIGURE 23)

Installation

- a. Install the slam-shut controller in a covered area and protect it against weather agents.
- b. Check that data on the plate are compatible with actual working conditions.
- c. Make sure slam-shut controller is installed upright, i.e. screw (key 49) on top.



CAUTION

Mounting in any other way will jeopardize slam-shut controller's performance.

- d. Carry out the connection of gas outlet (A). It must be derived from the pressure control piping, in a straight tract, possibly far away from restrictions, curves or derivations, in order to avoid turbulence that can alter the trip pressure setpoints.

Startup

- a. Using lever, activate slam-shut by turning reset pin (key 6) in the direction shown by the arrow.
- b. Wait until the pressure being controlled stabilizes and then slowly release lever.
- c. Now repeat this procedure, make sure that levers keep slam-shut controller properly set and that lever (key 33) is in horizontal position.

Periodical Checks

It is recommended that slam-shut controller be efficiency checked periodically.

Cut-off Test

- a. Cut-off the circuit by means of inlet and outlet valves and disconnect the pressure control pipe (A). The Slam-shut controller should cut-off at minimum pressure (only if so set).
- b. Through the pressure control connection, use a small pump or other appropriate means, to raise the pressure to normal operating level. Reset slam-shut controller after cut-off in step a.
- c. Simulate pressure increase until maximum pressure cutoff value is reached.

- d. Connect the pressure control actuator (A) and set the circuit back to operating conditions by following the instructions described in the Startup section.

Valve-seal Check

- a. Slowly close the valve located downstream.
- b. Press the "EMERGENCY" button. This will cause the immediate closing of slam-shut device.
- c. Loosen a connector in the downstream line of the slam-shut device or of the regulator. Check the connector with soap and water, making sure there are no leaks; make any necessary repairs otherwise.

Maintenance

Routine slam-shut controller maintenance entails simply periodic checking of the diaphragm on the Type OS/80X (the piston Lip seal on the Type OS/84X) and the movement of the levers, i.e. they should move freely with a minimum of friction. If necessary, lubricate pins with "Molykote 55 M".



WARNING

To avoid personal injury or property damage:

- **Only qualified personnel should install, service or perform maintenance on a regulator, the pilots or accessories.**
- **If necessary, contact our technical support representatives or our authorized dealers for additional information.**
- **Before attempting disassembly of the regulator, pilots or control lines, isolate the regulator from all pressure.**
- **Release all pressure trapped within the regulator, pilots and control lines.**
- **After regulator, pilot and control line maintenance, disassembly or repair, test the equipment for external and internal tightness according to applicable codes.**
- **Use an appropriate leak detect solution to test for any leakage in the equipment.**

Replacing Diaphragm (OS/80X Series only)

- a. Remove screws (key 27) and cover (key 61).
- b. Replace diaphragm (key 62).
- c. To remount diaphragm, coat it with grease, set it in place around the edge of cover (key 61) and evenly tighten screws (key 27) to ensure proper sealing.

Replacing O-ring (Types OS/84X and OS/88X only)

- a. Remove plug (key 61) and extract piston (key 68) from body (key 60).
- b. Replace O-ring (key 67) and lip seal (key 66).
- c. Reassemble by reversing the above procedures.

General Maintenance

- a. Remove screws (key 40) and casing (key 47).
- b. Remove dowels (key 12) and bushing (key 13).

Type FL

- c. Slide off pin (key 6), lever assembly (key 17-2), balls (key 10) and shim ring (key 15). Wash parts, replace any if worn.
- d. Remove nuts (key 18), levers (keys 20 and 36) and springs (keys 37 and 21).
- e. Remove nut (key 30), screw (key 29) and lever (key 33).
- f. Remove minimum register screw (key 49), maximum register ring (key 50) and springs (keys 53 and 54).
- g. Remove cover (key 61) on OS/80X Series, or body (key 60) on Types OS/84X and OS/88X, and proceed as directed in Replacing Diaphragms and Replacing O-ring sections.
- h. Remove nut (key 70) and locknut (key 69), then slide off stem assembly (key 57).
- i. Loosen dowel (key 3), unscrew ring (key 9), remove ball holder (key 5) and check seals (keys 4 and 8) for wear.
- j. Clean all metal parts with petrol, replace any if worn.

Reassembly

Reassemble all parts by reversing the steps in the general maintenance section.

As you proceed, make sure all parts move freely without friction. If necessary, lubricate them with Molykote 55 M.

Make sure to:

- a. Narrow the gap between nuts (keys 30 and 18) so that levers (keys 33, 36 and 20) have minimum play yet move freely without friction.
- b. Before mounting minimum spring (key 54), register position of lever (key 33) by means of nut (key 70), locking it into place with locknut (key 69).

CAUTION

The lever (key 33) is in proper position when it is exactly horizontal and in the center of the groove of lever (key 36).

- c. Now remount lever assembly (key 17-2), balls (key 10), keeping them in their seat with grease, and stem (key 6), which is to be turned so the balls enter their seats. The stem and lever assembly should now be tightly fitted together.
- d. Remount bushing (key 13), make sure that the dowels are firmly set in the grooves of the stem (key 6).
- e. Repeatedly check if pilot resets properly and, lastly, remount minimum spring (key 54).
- f. Always check pilot setting.

Minimum and Maximum Setting

- a. Make sure that the lever (key 33) is in horizontal position when pilot is reset. If necessary, use nut and locknut (keys 69 and 70) to adjust (see step b, Reassembly section).
- b. Use ring nut (key 50) to completely load maximum pressure spring (key 53). Loosen screw (key 49) to completely relieve minimum pressure spring (key 54).
- c. Disconnect pressure control pipe (A).
- d. Through the pressure control connection, use a small pump or other appropriate means to raise the pressure to normal operating level.

- e. Reset pilot and reduce the pressure until it reaches minimum cutoff level.
- f. Use register (key 49) to load spring (key 54) slowly until pilot is triggered.
- g. Repeat procedures (d) and (e) above, making any necessary adjustment in the setting.
- h. Bring pressure back to normal values.
- i. Reset pilot and raise the pressure until it reaches maximum cutoff level.
- j. Using ring nut (key 50), slowly unload spring (key 53) until cut-off point is reached.
- k. Repeat procedures (h) and (i) above, making any adjustment necessary in the setting.

CAUTION

Whenever minimum or maximum pressure setting is not required, omit corresponding steps.

PILOT MAINTENANCE TYPES PRX/120, PRX/125, PRX-AP/120 AND PRX-AP/125 (SEE FIGURE 24)

Installation

- a. Make sure that specifications on the pilot plate comply with the intended use.
- b. Make sure that all connections are correctly made.

Startup

Refer to the regulator startup instructions.

Adjustment

Adjusting response stability and rapidity is achieved by means of the appropriate adjusting screws, R (restrictor) and D (damper).

The register D is normally completely unscrewed; by screwing the register, the response of the regulator can be slowed down.

The register R is normally completely screwed; in case of hunting of the set pressure, we suggest unscrewing slowly the register until pressure steadiness is reached. To increase the speed at which a monitor regulator takes control, unscrew the register on the monitor pilot until the closing speed is satisfactory.

By unscrewing the register, the set pressure decreases; intervene on register screw (key 1) in order to re-establish the correct pressure.

CAUTION

If register R is completely unscrewed, the regulator can not deliver the maximum requested capacity. In order to better assess the effects of adjustments, it is advisable to turn the adjusting screws only one fourth of a turn at a time and to verify the new conditions before carrying out the further rotation.

Periodical Checks

Gas-tightness Test

When starting up the regulator, and at regular intervals, check gas tightness as follows:

- Slowly close downstream cut-off valve.
- In order to avoid excessive lock-up pressures, close the valve and simultaneously open the outlet vent tap. In case of safety slam-shut device being fitted, keep this valve manually open in order to prevent it from tripping.
- Slowly close the vent tap and read the lock-up pressure value. An increase in outlet pressure will initially be detected, after which pressure will stabilize. If, on the contrary, outlet pressure continues increasing, then the seal is defective. Check if leak is ascribable to pilot or regulator.

Checking Pilot Gas Tightness

- Link up together connection A, connection B, a vent tap and a pressure gauge with appropriate scale.
- Close connection L.
- Slightly open vent tap, feed either gas or compressed air to the pilot through connection S. Pressure gauge will show the pilot set pressure.
- Close vent tap and read the lock-up pressure value, which should be less than 0.4 bar. If this value is higher than 0.4 bar, pilot pad or seal seat are worn out or damaged.
- Use soapy water to check there are no gas leaks.

Maintenance



WARNING

To avoid personal injury or property damage:

- Only qualified personnel should install, service or perform maintenance on a regulator, the pilots or accessories.
- If necessary, contact our technical support representatives or our authorized dealers for additional information.
- Before attempting disassembly of the regulator, pilots or control lines, isolate the regulator from all pressure.
- Release all pressure trapped within the regulator, pilots and control lines.
- After regulator, pilot and control line maintenance, disassembly or repair, test the equipment for external and internal tightness according to applicable codes.
- Use an appropriate leak detect solution to test for any leakage in the equipment.

General Maintenance

- Disconnect and remove the pilot from the line.
- Fully unscrew the adjusting screw (key 1).

- Unscrew the cap (key 3), remove the spring holder (key 6) and the spring (key 7). Replace the O-rings (keys 4 and 5).
- Loosen screws (key 10), remove the upper cover (key 8) and the lower cover (key 21). Replace the O-ring (key 18).
- Lock the stem (key 23) by inserting a key into the notches and unscrew nuts (keys 20 and 26).
- Disassemble the parts and replace the diaphragm (key 14) and the pad (key 22).
- Unscrew the seat (key 19) and replace the O-ring (key 17).
- Use petrol to cleanse the pilot body and all metal parts. Blow them thoroughly with compressed air and check for clear holes along the gas conduits. Replace any worn parts.

Reassembly

Reassemble all parts by following in reverse order the assembly as described above (see General Maintenance section).

As parts are assembled, make sure they move freely causing no friction.

Make sure to:

- O-rings and diaphragms should be lubricated by applying a thin layer of 'Molykote 55 M' grease. Pay attention not to damage them during reassembly. All other pilot parts require no lubrication.
- The cover clamping screws (key 10) should be tightened evenly to ensure proper tightness.
- Pilot operation, calibration and tightness should be tested as described in the Gas-tightness test section.
- Previously disassembled fittings must be connected. Check for leaks by using suds.

Calibration

See the paragraph Pilot Adjustment on page 14.

TYPES PRX/181-PN, PRX/182-PN PILOTS AND PRX/131 BOOSTER VALVES (SEE FIGURES 25 AND 26)

Installation

Identical to Type PRX/120, PRX/125 Series (see page 18).

Startup

Identical to Type PRX/120, PRX/125 Series (see page 18).

Periodical Checks

Pilot tightness should be tested regularly by referring to the following procedure:

- Supply fitting A with normal operating pressure.
- Make sure there is no gas outflow from fitting B.

Type FL

Maintenance

Identical to Type PRX/120, PRX/125 Series (see page 18).

Calibration

Identical to Type PRX/120, PRX/125 Series (see page 18).

TYPE PS/79, RE/79, PS/80 AND RE/80 (SEE FIGURE 26)

Installation

- Make sure that data on the pilot's plate are compatible with actual working conditions.
- Install as directed for regulator.

Startup

Refer to the startup instructions applying to the regulator.

Periodical Checks

Slowly close the outlet slam-shut and check line pressure between it and regulator.

A slight increase in pressure should be detected: this results from overload due to closing, and is followed by pressure stabilization. If, however, outlet pressure continues to rise, then seal is defective. Check if leak is coming from regulator or pilot, and service.

Maintenance

WARNING

To avoid personal injury or property damage:

- Only qualified personnel should install, service or perform maintenance on a regulator, the pilots or accessories.
- If necessary, contact our technical support representatives or our authorized dealers for additional information.
- Before attempting disassembly of the regulator, pilots or control lines, isolate the regulator from all pressure.
- Release all pressure trapped within the regulator, pilots and control lines.
- After regulator, pilot and control line maintenance, disassembly or repair, test the equipment for external and internal tightness according to applicable codes.
- Use an appropriate leak detect solution to test for any leakage in the equipment.

Replacing Filter

- Remove the screws (key 41), cover (key 59) and replace felt (key 61).

Reassemble by reversing the above sequence.

Replacing Stabilizer Diaphragm and Seal Pad

- Remove screws (key 41), cover (key 64), spring (key 47) and diaphragm assembly (keys 48, 49, 50, 51, 52 and 53). Replace diaphragm if necessary.
- Unscrew seat (key 54) and replace pad holder (key 56).
- Reassemble by reversing the above sequence, make sure not to "pinch" O-rings (key 55).

Replacing Valve Seal Pads

- Remove plug (key 27) and seat (key 30). Slide out spring (key 32), pad holder unit (key 34) and forked stem (key 35).
- Replace pad holder (key 34) and O-ring (key 37).

Reassemble by reversing above sequence.

General Maintenance

- Completely release spring (key 5) by turning the adjusting screw (key 1) counter clockwise.
- Remove screws (key 7) and cover (key 4).

CAUTION

This must be done exactly as described to prevent damage to or breaking of safety valve (key 20).

- Keep plate (key 9 or 75 for the AP version) blocked with a box wrench, unscrew nut (key 6). This must be done exactly as described to prevent damage to or breaking of safety valve (key 20).
- Unscrew plate (key 9 or 75 for the AP version) from stem (key 13) remove parts (keys 10, 11, and 12 or 76, 78, 10, 77 and 12 for the AP version).
For PS/80 and PS/80-AP version:
Unscrew plate (key 9 or 75 for the AP version) from stem (key 13) remove parts (keys 10, 68, 69, 11, and 12 or 76, 78, 68, 69, 10, 77 and 12 for the AP version).
- Slide off split pin (key 40). Remove locknut (key 16) with appropriate wrench and slide out parts (key 17, 18, 19 and 20).
- Make sure that the surface of seat (key 26) which is sealed by pad (key 21) is in proper condition.
- Replace diaphragms (key 10) and all seals.
- Proceed as directed in the replacement of filter, stabilizer diaphragm and seal pad, and valve seal pads (see instructions above).

Reassembly

Lubricate the static O-rings with a thin layer of Molykote 55 M, be very careful not to damage the O-rings when reassembling. No other pilot parts are to be lubricated.

Reassemble parts by reversing the above steps. As you proceed, make sure that parts move freely and without friction.

In addition:

- a. Once lever (key 39) and stem (key 13) have been mounted with stem (key 13) against body (key 25), check that a clearance between forked stem (key 35) and registered (A) of lever (key 39) is 0.2 to 0.3 mm. If this is not the case, use register to correct.



CAUTION

The above clearance can be checked by gently pulling stem (key 13) upward.

Use the proper tool to make sure that the top plate (key 9) is on the same plane as the supporting the diaphragm (key 10) in the body (key 25).

- b. Mount diaphragm (key 10) and screw on plate (key 9), first by hand then with box wrench, (always holding upper diaphragm (key 10) firmly in place) in order to avoid damage to stem (key 13) and levers below.
- c. Holding plate (key 9) firmly in place with box wrench, tighten nut (key 6).
- d. Before remounting cover (key 4), center diaphragm as follows:
 - mark a reference point (with pencil) on the diaphragm;
 - turn it to the right without forcing and mark another reference on body
 - turn diaphragm to the left and mark a further reference
 - position the diaphragm mark midway between the two marks on the body.
- e. Tighten all screws uniformly to ensure proper sealing.

Calibration

See the paragraph Pilot Adjustment on page 14.



CAUTION

The pilot has a wide range of self-adjustment values. However, given actual operating conditions, it may necessary to assist it at times by finding the best setting of register/ pin screw (key 29) or the most suitable calibration jet (key 15).

TYPE PS/79-1, PS/79-2, RE/79-1 AND RE/79-2 PILOTS (SEE FIGURE 27)

Installation

Identical to Type PS/79 and 80 Series (see page 20).

Startup

Identical to Type PS/79 and 80 Series (see page 20).

Periodical Checks

Identical to Type PS/79 and 80 Series (see page 20).

Maintenance



WARNING

To avoid personal injury or property damage:

- Only qualified personnel should install, service or perform maintenance on a regulator, the pilots or accessories.
- If necessary, contact our technical support representatives or our authorized dealers for additional information.
- Before attempting disassembly of the regulator, pilots or control lines, isolate the regulator from all pressure.
- Release all pressure trapped within the regulator, pilots and control lines.
- After regulator, pilot and control line maintenance, disassembly or repair, test the equipment for external and internal tightness according to applicable codes.
- Use an appropriate leak detect solution to test for any leakage in the equipment.

Replacing Filter

- a. Remove screws (key 54), cover (key 58), and replace felt (key 41). Reassemble by reversing the above sequence.

Replacing Stabilizer Diaphragm and Seal Pad

- a. Remove screws (key 54), cover (key 55), spring (key 52) and diaphragm assembly (keys 53, 51, 50, 49, 48 and 47). Replace diaphragm if necessary.
- b. Unscrew seat (key 44) and replace pad holder (key 45).
- c. Reassemble by reversing the above sequence.

Replacing Valve Seal Pads

- a. Remove plug (key 23) and seat (key 25). Slide out spring (key 27), pad holder unit (key 29) and forked stem (key 31).
- b. Replace pad holder (key 29) and O-ring (key 32).
- c. Reassemble by reversing above sequence.

Type FL

General Maintenance

- Proceed as directed in the replacement of filter, stabilizer diaphragm and seal pad, and valve seal pads (see instructions above).
- Completely release spring (key 5) by turning the adjusting screw (key 1) counter clockwise.
- Remove screws (key 10) and cover (key 6).

CAUTION

This must be done exactly as described to prevent damage to or breaking of drilled needle valve (key 17)

- Keep plate (key 8) blocked with a box wrench, unscrew nut (key 7).
- Unscrew plate (key 8) from stem (key 12) and slide off split pin (key 35).
- In Types RE/79-1 and 2, remove locknut (key 15) by means of an appropriate wrench and slide out parts (keys 62, 63, 16 and 17), make sure that the surface of seat (key 61) is intact.
- Replace any worn seals.

Reassembly

Lubricate the static O-rings with a thin layer of Molykote 55 M, be very careful not to damage the O-rings when reassembling. No other pilot parts are to be lubricated.

Reassemble parts by reversing the above steps. As you proceed, make sure that parts move freely and without friction. In addition:

- Once lever (key 36) and stem (key 12) have been mounted, check that, with stem (key 12) against body (key 19), clearance between forked stem (key 31) and registered of lever (key 36) is 0.2 to 0.3 mm. If not, use register to correct.

CAUTION

The above clearance can be checked by gently pulling the stem (key 12) upward. Use the proper tool to make sure that support of diaphragm (key 9) on the stem (key 12) is on the same plane as that supporting the diaphragm (key 9) in the body (key 19).

- Mount diaphragm (key 9) and screw on plate (key 8), first by hand then with box wrench, always keep diaphragm (key 9) firmly in place to avoid damage to stem (key 12) and underlying levers.
- Holding plate (key 8) firmly in place with box wrench, tighten nut (key 7).
- Before remounting cover (key 6), center diaphragm as follows: mark a reference point (with pencil) on the diaphragm; turn it to the right without forcing and mark another reference on body. Now turn diaphragm to the left and mark a further reference. Position the diaphragm mark midway between the two marks on the body.
- Tighten all screws uniformly to ensure proper sealing.

Calibration

See the paragraph Pilot Adjustment on page 14.

CAUTION

The pilot has a wide range of self-adjustment values. However, given actual operating conditions, it may necessary to assist it at times by finding the best setting of pin screw/register (key 24) or the most suitable calibration orifice (key 18).

BOOSTER VALVE MAINTENANCE TYPE V/31-2 (SEE FIGURE 28)

- Disconnect all fittings, remove valve from the line and unscrew nuts (key 13) then remove cover (key 4), spring holder (key 5) and spring (key 6).
- Replace gasket (key 26).
- Hold stem (key 19) using a wrench inserted into the notch and unscrew nut (key 7).
- Disassemble parts and replace diaphragm (key 10) and O-ring (key 22).
- Unscrew seat (key 16) and replace O-ring (key 15).
- Using a tube wrench disassemble pad holder (key 18) and replace pad (key 17).
- Remove stem unit (key 19), unscrew stem guide (key 20), replace O-ring (key 15) and lip seals (key 21).

STABILIZER FILTER MAINTENANCE TYPE SA/2 (SEE FIGURE 29)

Replacing Filter

- Remove screws (key 2), cover (key 11); replace felt (key 12) and O-ring (key 13). Reassemble in reverse order the above sequence.

Replacing Stabilizer Diaphragm and Seal Pad

- Remove cover (key 19); spring (key 1) and diaphragm assembly (keys 21, 20, 3, 4, 18 and 17). Replace diaphragm if necessary.
- Unscrew seat (key 5), replace pad holder (key 15) and O-ring (key 6).
- Reassemble in reverse order the above sequence.

WASTE DISPOSAL REQUIREMENTS

The disposal of waste and e-waste from packaging, spare parts, lubricants, whole equipment/systems and produced in occasion of on-site surveillance activities (during service life and/or at the end of their service life), shall be carried out in accordance with the requirements of applicable local regulation (laws and rules).

SPARE PARTS

Spare parts storage shall be done by proper procedures according to national standard/rules to avoid over aging of rubber parts or any damage to critical parts.

TROUBLESHOOTING

Table 12. General Troubleshooting for FL Series Regulator

SYMPTOMS	CAUSE	ACTIONS
The regulator does not open	Lack of incoming gas	Check the station feeding
	Pilot is not being supplied gas pressure on either the inlet or sensing connections	Check pilot connections
	Regulator diaphragm is broken	Replace the diaphragm
	The slam-shut device has not been reset	Manually reset the slam-shut device
Drop in pressure downstream from the regulator	Insufficient upstream pressure	Check the station feeding
	Flow requirements higher than the flow that the regulator can supply	Check the regulator sizing
	Downstream control valve partially closed	Open downstream valve completely
	Faulty supply to or leakage from the pilot	Check pilot connections and internal parts
	Filter upstream is obstructed	Clean or replace filter
Increase in pressure downstream from the regulator	Tight shutoff parts (o-ring, pad) are worn	Replace leaking parts
	Deposits of grime on the pad are obstructing proper seal of the shutter	Clean or replace the pad
Regulator hunting	Control intakes in incorrect positions	Check connections position
	Very low flow demand	Check the pilots setting and tuning
	Pilot supply and discharge valves are not adjusted perfectly	Check supply and discharge valves opening position
Freezing occurs	Wet Gas; no heat or insufficient heat applied to pilots	Increase gas heating temperature or dry the gas
Slam-shut device does not execute tight shutoff procedure (only for BFL version)	O-ring and/or slam-shut pad worn	Replace O-ring and/or pad
	Slam-shut seat damaged	Replace seat or sleeve

Table 13. Troubleshooting for Types PS/79-1, PS/79-2, RE/79-1 and RE/79-2 Pilots

SYMPTOMS	CAUSE	ACTIONS
Desired setpoint is not reached	Calibration spring (5) is too weak	Check the springs catalogue and replace it with a stronger one
	Leaks from pilot connections	Check pilot feed connections and proper gas flow feeding
Outlet pressure drops well below setpoint	Filter (key 41) is clogged preventing proper through-flow of gas	Clean or replace filter (key 41)
	Pad holder (key 45) is swollen preventing proper feed flow	Replace pad holder (key 45)
	Pad holder (key 29) is swollen preventing proper feed flow	Replace pad holder (key 29)
Outlet pressure increases over setpoint	Faulty sealing of pad holder (key 45)	Replace pad holder (key 45)
	Faulty sealing of pad holder (key 29)	Replace pad holder (key 29)
Slow response to changes in gas demand	Insufficient flow rate of valve seat (key 25)	Increase flow by means of register/pin screw (key 24)
	Over sized calibration jet (key 18) (only for Types PS/79-1 and PS/79-2)	Replace jet (key 18) with a smaller one
Overly rapid response to changes in gas demand, i.e. Hunting	Excessive flow rate of valve seat (25)	Reduce flow by means of a pin screw (key 24)
	Calibration jet (18) is too small (only for Types PS/79-1 and PS/79-2)	Replaced with a larger one
	Improper internal parts assembly	Check clearance between lever (key 36) and valve seat (key 25)
Gas continually escaping from relief (S)	Defective seal of pad (key 59) (only for Types RE/79-1 and RE/79-2)	Replace pad (key 59)

Type FL

Table 14. Troubleshooting for Types PS/79, RE/79, PS/80 and RE/80 Pilots

SYMPTOMS	CAUSE	ACTIONS
Desired setpoint is not reached	Calibration spring (key 5) is too weak	Check the springs catalogue and replace it with a stronger one
	Leaks from pilot connections	Check pilot feed connections and proper gas flow feeding
Outlet pressure drops well below setpoint	Filter (key 61) is clogged preventing proper through-flow of gas	Clean or replace filter (key 61)
	Pad holder (key 56) is swollen preventing proper feed flow	Replace pad holder (key 56)
	Pad holder (key 34) is swollen preventing proper feed flow	Replace pad holder (key 34)
Outlet pressure increases over setpoint	Faulty sealing of pad holder (key 56)	Replace pad holder (key 56)
	Faulty sealing of pad holder (key 34)	Replace pad holder (key 34)
Slow response to changes in gas demand	Insufficient flow rate of valve seat (key 30)	Increase flow by means of register/pin screw (key 29)
	Over sized calibration jet (key 15) (only for Types PS/79 and PS/80)	Replace jet (key 15) with a smaller one
Over rapid response to changes in gas demand, i.e. Hunting	Excessive flow rate of valve seat (key 30)	Reduce flow by means of a pin screw (key 29)
	Calibration jet (key 15) is too small (only for Types PS/79 and PS/80)	Replace with a larger one
	Improper internal parts assembly	Check clearance between lever (key 39) and forked stem (key 35)
Gas continually escaping from relief (S)	Defective seal of pad (key 21)	Replace pad (key 21)
The outlet pressure is not within the usual values	Diaphragm (key 10) is damaged	Replace diaphragm (key 10)
	Upper diaphragm (key 10) is damaged (only for Types PS/80 and RE/80)	Replace diaphragm (key 10)

Table 15. Troubleshooting for OS/80X Series Slam-shut Controller

SYMPTOMS	CAUSE	ACTIONS
Slam-shut controller does not remain set	The actuator impulse intake (A) is not connected properly	Check connections (A)
	Downstream pressure coincides with the maximum or minimum slam-shut settings	Check slam-shut settings
	Diaphragm (key 62) is damaged (Lip seal (key 66) on Types OS/84X, OS/88X)	Replace diaphragm (key 62)

PARTS LIST**Types FL and MFL Regulator
(See Figures 10 to 21)**

Item	Description	Item	Description	Item	Description
1	Inlet flange	205	Disk	503	Plate
2*	Anti-friction ring	206	Auto-locking nut	504	Indicator
3*	O-ring	207	Plate	505	Bushing
4*	O-ring	208	Plate	506*	O-ring
5	Screw	209	Stud bolt	507*	O-ring
6	Spring	210	Pipe	508	Support
7	Fitting	211	Spring	509	Spring collet
8	Inlet plate	212	Screw	512	Spacer
9	Screw	213	Plate	513	Screw
10*	Diaphragm	215	O-ring	514*	Backup ring
11	Inlet Cover	216	Spacer	700	Microswitch
12	Outlet plate	217	Spacer	701	Bracket
13	Outlet cover	218	O-ring	702	Indicator
14	Washer	219	Screw	703	Bushing
15	Nut	220	Washer	704	Nut
16	Sleeve (Shutter)	221	Base Plate	705	Support
17	Fitting	222	Nut	706*	O-ring
18*	O-ring	223	Rod	707*	O-ring
19	Pad holder	224	Plate No. 2	708	Spring collet
20*	Pad unit	225	Plate No. 3	710*	Backup ring
21	Pad retainer	226	Plate No. 4		
22	Outlet flange	227	Plate No. 5		
23	Gasket	228	Spacer No. 1		
24	Disassembly spacer	229	Spacer No. 2		
25	Screw	230	Spacer No. 3		
26*	O-ring	231	Spacer No. 4		
27	Screw	232	Cap Screw		
28*	O-ring	233	O-ring		
29	Label support	234	End plate		
30	Label	235	Locknut		
31	Rivet	236	O-ring		
32	Label	237	Cap Screw		
33	Spring collet	238	Eyebolt		
34	Indicator	271*	Backup ring		
35*	O-ring	300	Bracket		
36	Support	301	Spring		
37*	O-ring	302	Bushing		
38	Bushing	303	Nut		
39	Indicator label	304*	O-ring		
40	Cap	305*	O-ring		
41	Stub pipe	306	Spring		
42	Plug	307	Ratchet		
43	SR/SRII silencer	308	Support		
46*	O-ring	309	Indicator		
47*	O-ring	310	Ratchet		
48	Washer	311	Transducer		
59	Eyebolt	312	Spring collet		
61	Special screw	313*	Backup ring		
62	Screw	400	Plate		
63	Elastic washer	401	Bushing		
64	Screw	402*	O-ring		
65	Elastic pin	403	Support		
66	Eyebolt	404*	O-ring		
67	Pad support	405	Spring collet		
200	Widened outlet flange	406	Indicator		
201	Support	407	Nut		
202	Nut	408	Bracket		
203	Support	409	Support		
204	Elastic pin	410	Proximity switch		
		411	Fitting		
		413*	Backup ring		
		500	Transducer		
		501	Bracket		
		502	Nut		

Type FL

Type BFL Regulator with Slam-shut (See Figure 22)

Item Description

100	Inlet flange
107*	O-ring
110	Disk
111	Washer
112	Nut
113	Stud bolt
114	Spring
115*	O-ring
117	Sleeve (Shutter)
119	Anti-friction ring
120*	O-ring
121	Shaft unit
122	Elastic ring
123	Pin
124	Hub
125*	O-ring
126*	O-ring
127	Disk
128	Bearing
133	Special screw
135	Screw
137	Lever unit
190	Stub pipe
191	Fitting
192	Hub
193	Shaft

Type OS/80X Series Slam-Shut Controller (See Figure 23)

Item Description

1	Plate
2	Releasing bushing
3	Screw
4*	Gasket
5	Balls holder
6	Stem
7	Roller
8*	O-ring
9	Reloading nut
10	Ball - Roller
11	Roller
12	Screw
13	Reloading bushing
14*	O-ring
15	Ring
17	Reloading lever unit
18	Self-locking nut
19	Washer
20	Return lever
21	Spring
22	Fulcrum
24	Label
26	Nut
27	Screw
28	Reloading pin
29	Screw
30	Self-locking nut
31	Washer
32	Plate fulcrum

Item Description

33	Lever
34	Screw
35	Cone
36	Releasing lever
37	Spring
38	Plug
39	Locking pin
40	Screw
41	Indicator pin
42	On-Off indicator
43	Button
44*	O-ring
45	Spring
46	Gasket
47	Casing
48	Screw
49	Minimum pressure adjusting screw
50	Maximum pressure adjusting nut
51	Pipe assembly
52	Washer
53	Spring
54	Spring
55	Lower spring holder unit
56	Elastic ring
57	Stem unit
58	Spring
59	Plate holding stem unit
60	Top cover
61	Lower cover
62*	Diaphragm
63	Screw
64	Block
65*	O-ring
66*	Lip seal
67*	O-ring
68	Piston
69	Nut
70	Locknut
71	Proximity
73*	Gasket (only for BP, BPA-D, MPA-D)
74	Filter
75	Pin
76	Nut
77	Microswitch
78	Plate
80	Shaft
81	Spacer
82	Screw
83	Pin
84	Ring

Types PRX/120, PRX/125, PRX-AP/120 and PRX-AP/125 Pilots (See Figure 24)

Item	Description
1	Adjusting screw
2	Nut
3	Cap
4*	O-ring
5*	O-ring
6	Spring carrier plate
7	Spring
8	Upper cover
9	Spring carrier plate
10	Screw
11	Washer
12	Filter
13	Plate
14*	Diaphragm
15	Plate
16	Body
17*	O-ring
18*	O-ring
19	Seat
20	Nut
21	Lower cover
22*	Pad holder unit
23	Stem
24	Plate
25*	O-ring
26	Nut
27	Adjusting screw
28*	O-ring
29	Plate
30	Ring nut
31	Screw
32	Adjusting screw with hole
33	Plug
34	Plug
35	Spring barrel extension for AP

Type PRX/131 Booster Valve (See Figure 25)

Item	Description
1	Adjusting screw
2	Nut
3	Cap
4*	O-ring
5*	O-ring
6	Spring carrier plate
7	Spring
8	Upper cover
9	Spring carrier plate
10	Screw
11	Washer
12	Filter
13	Plate
14*	Diaphragm
15	Plate
16	Body
17*	O-ring
18*	O-ring

Item	Description
19	Seat
20	Nut
21	Lower cover
22*	Pad holder unit
23	Stem
24	Plate
25*	O-ring
26	Nut
28*	O-ring
29	Plate
31	Screw
33	Plug
34	Plug

Types PRX/181-PN and PRX/182-PN Pilots (See Figure 26)

Item	Description
36	Lower cover
37*	O-ring
38	Special connection

Types PS/79, RE/79, PS/80 and RE/80 Pilots (See Figure 27)

Item	Description
1	Adjusting screw
2	Nut
3	Spring holder
4	Cover
5	Spring
6	Nut
7	Screw
8	Washer
9	Plate
10*	Diaphragm
11	Plate
12*	O-ring
13	Stem
14*	O-ring
15*	Jet
16	Locking nut
17*	Lip seal
18	Thrust bearing
19	Spring
20	Safety valve
21*	Pad
22*	O-ring
23*	O-ring
24	Plug
25	Body
26	Seat
27	Plug
28*	O-ring
29	Pin screw
30	Seat
31*	O-ring
32	Spring
34*	Pad holder unit
35	Forked stem
36	Spacer

Type FL

Types PS/79, RE/79, PS/80 and RE/80 Pilots (See Figure 27) (continued)

Item	Description
37*	O-ring
38*	O-ring
39	Lever unit
40	Split pin
41	Screw
42	Washer
43	Elastic ring
44	Data plate
45	Silencer
46	Pin
47	Spring
48	Auto-locking nut
49	Washer
50	Washer
51	Plate
52*	Diaphragm
53	Screw unit
54	Seat
55*	O-ring
56*	Pad holder unit
57	Spring
58*	O-ring
59	Filter cover
60	Filter net
61*	Felt
62*	O-ring
63	Pawl
64	Cover
65	Plug

Type PS/80

Item	Description
66	Elbow Fitting
67	Screw
68	Middle flange
69	Hub

Types RE/79, RE/80, REO/79 and REO/80

Item	Description
15	Plug

Types PS/79-D and PS/80-D

Item	Description
70	Extension
71*	O-ring
72	Elastic ring
73*	O-ring

Types PS/79-AP and PS/80-AP

Item	Description
75	Plate
76	Spacer
77	Plate
78*	O-ring
79	Spring holder

Types PS/79-1, PS/79-2, RE/79-1 and RE/79-2 Pilots (See Figure 28)

Item	Description
1	Adjusting screw
2	Nut
3	Cap
4	Spring holder
5	Spring
6	Cover
7	Nut
8	Plate
9*	Diaphragm
10	Screw
11*	Gasket (PS/79-1 and RE/79-1 only)
12	Stem
13	Washer
14	Nut
15	Locking nut
16	Spring
17	Drilled needle valve
18	Jet
19	Body
20*	O-ring
21	Plug
22*	O-ring
23	Plug
24	Pin screw
25	Seat
26*	O-ring
27	Spring
29*	Pad holder unit
30	Spacer
31	Forked stem
32*	O-ring
33*	O-ring
34	Screw
35	Split pin
36	Lever unit
37	Data plate
38	Pin
39	Elastic ring
40*	O-ring
41*	Felt
42	Filter net
43	Spring
44	Seat
45*	Pad holder unit
46*	O-ring
47	Screw unit
48*	Diaphragm

Types PS/79-1, PS/79-2, RE/79-1 and RE/79-2 Pilots (See Figure 28) (continued)

Item	Description
49	Plate
50	Washer
51	Washer
52	Spring
53	Auto-locking nut
54	Screw
55	Cover
56*	O-ring
57	Plug
58	Filter cover

Types RE/79-1 and RE/79-2

Item	Description
17	Safety Valve
59*	Pad
60*	O-ring
61	Seat
62	Thrust bearing
63*	Lip seal

Types PS/79-1-D, PS/79-2-D, RE/79-1-D and RE/79-2-D Pilots

Item	Description
69*	O-ring
70	Elastic ring
71*	O-ring

Type REOPS/79-1 Pilot

Item	Description
77	Body

Type V/31-2 Booster Valve (See Figure 29)

Item	Description
1	Adjusting screw
2	Nut
3	Cap
4	Cover
5	Spring holder
6	Spring
7	Nut
8	Washer
9	Plate
10*	Diaphragm
11	Screw
12	Washer
13	Nut
14	Fitting
15*	O-ring
16	Seat

Item	Description
17*	Pad
18	Pad holder
19	Stem
20	Stem guide
21*	Lip seal
22*	O-ring
23	Plate
24	Body
25	Screw
26*	Gasket
27	Label

Type SA/2 Stabilizer Filter (See Figure 30)

Item	Description
1	Spring
2	Screw
3	Washer
4	Plate
5	Seat
6*	O-ring
7	Body
8	Net
9	Washer
10	Nut
11	Filter cover
12*	Felt
13*	O-ring
14	Spring
15	Pad holder unit
16	Data plate
17	Screw plate unit
18*	Diaphragm
19	Upper cover
20	Washer
21	Nut

Rubber parts marked with (*) are supplied in the "spare parts kit", recommended as stock.

To order the kit it is necessary to communicate to us the type of the regulator or pilot and its serial number.

SCHEMATIC ASSEMBLIES

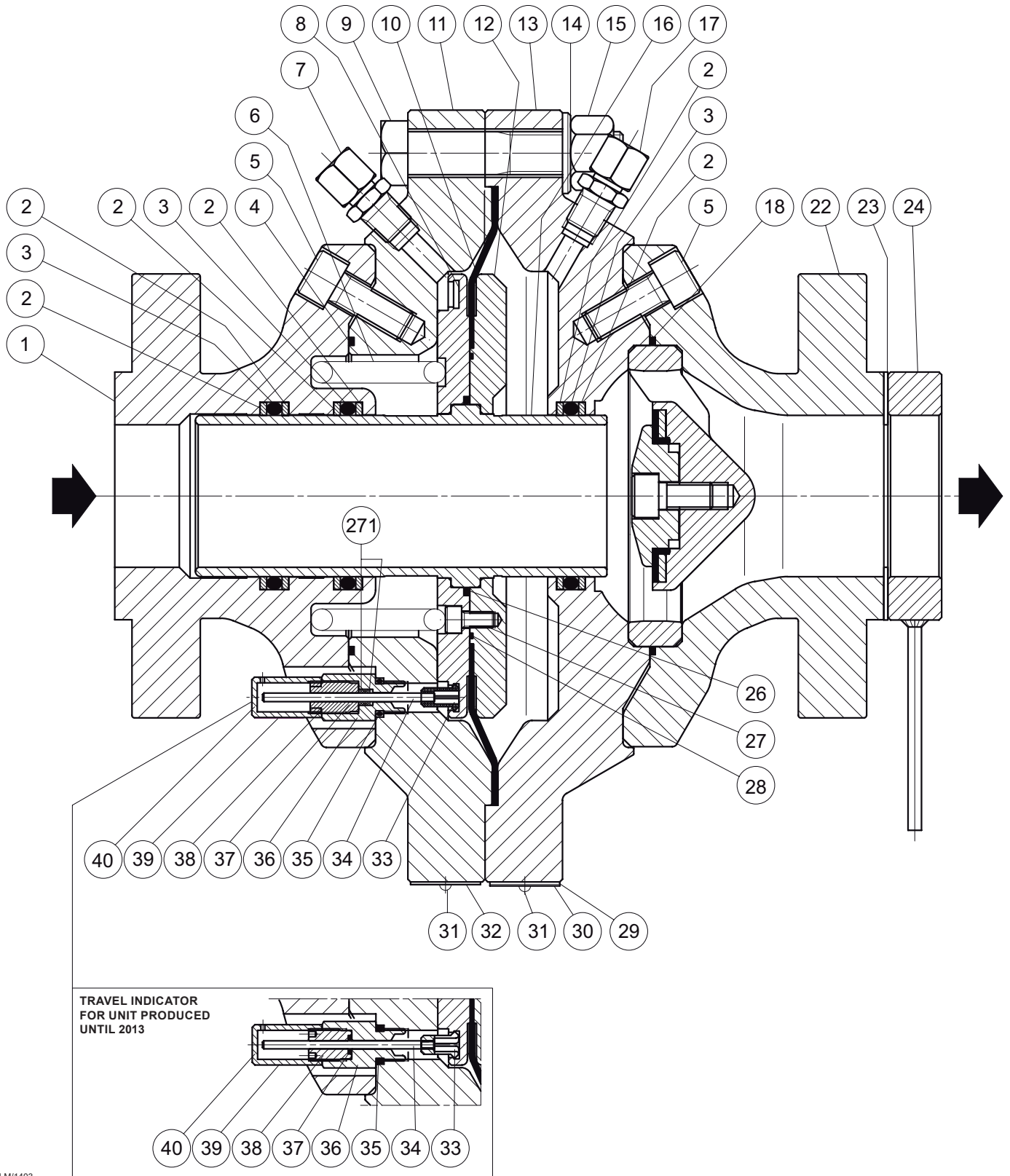

LM/1403

Figure 10. Type FL Regulator DN 25 to DN 150

FL/ AND BFL/ WITHOUT SILENCER

PAD HOLDER
DN 25 TO DN 50

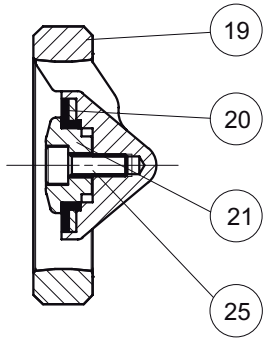

PAD HOLDER
DN 65 TO DN 150

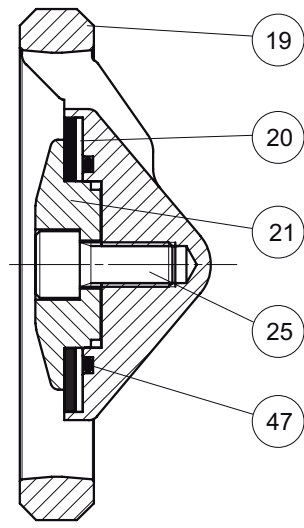

FL/ AND BFL/ WITH SR SILENCER

PAD HOLDER
DN 25 TO DN 50

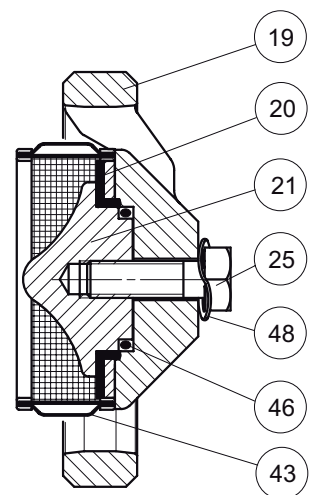

PAD HOLDER
DN 65 TO DN 150

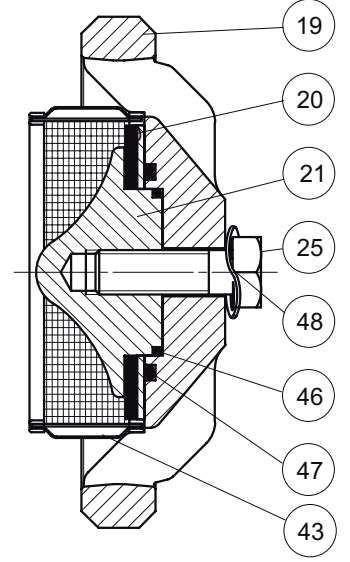

FL/ AND BFL/ WITH SR11 SILENCER

PAD HOLDER
DN 25, 50

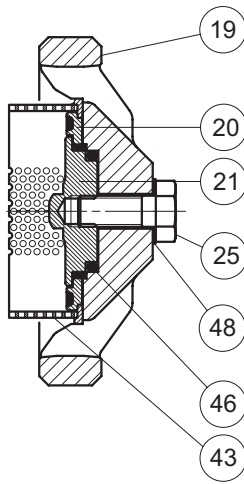

PAD HOLDER
DN 80, 100, 150

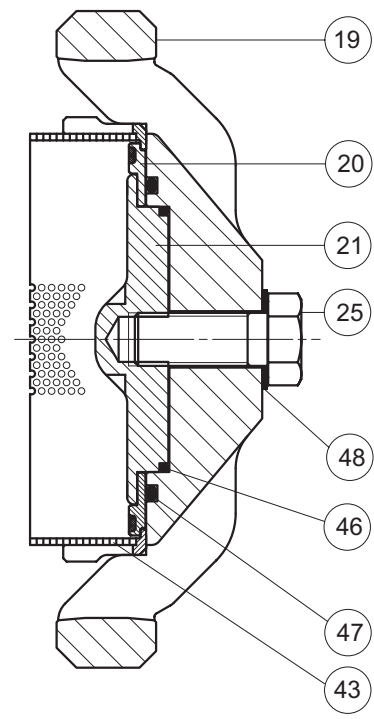

LM/1403

Figure 11. Pad Holder for Type FL Regulator DN 25 to DN 150 and for Types BFL / MFL Regulator DN 25 to DN 100

Type FL

FL/ AND BFL/ WITH POLYURETHANE PAD WITHOUT SILENCER

PAD HOLDER
DN 25, 50

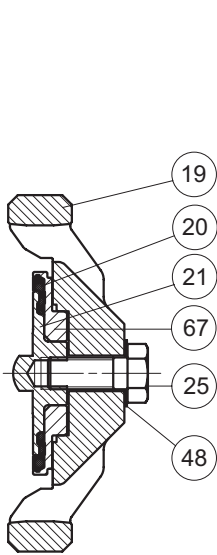

PAD HOLDER
DN 80, 100, 150

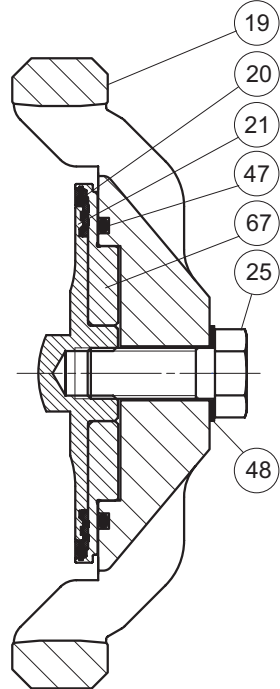

FL/ AND BFL/ WITH POLYURETHANE PAD AND SR SILENCER

PAD HOLDER
DN 25, 50

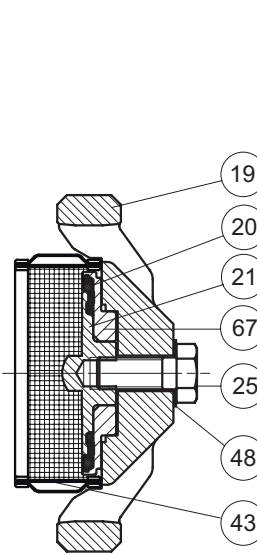

PAD HOLDER
DN 80, 100, 150

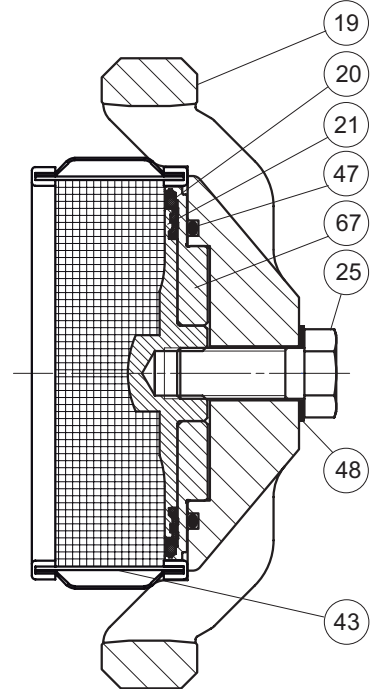

FL/ AND BFL/ WITH POLYURETHANE PAD AND SR11 SILENCER

PAD HOLDER
DN 25, 50

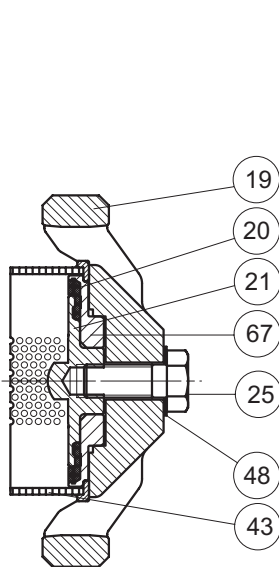

PAD HOLDER
DN 80, 100, 150

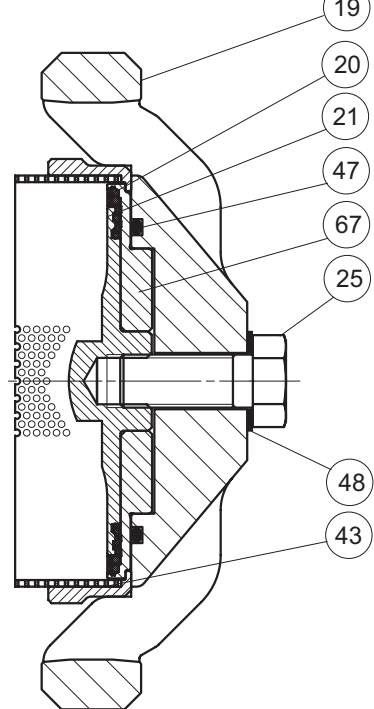

LM/1403

Figure 11. Pad Holder for Type FL Regulator DN 25 to DN 150 and for Types BFL / MFL Regulator DN 25 to DN 100 (continued)

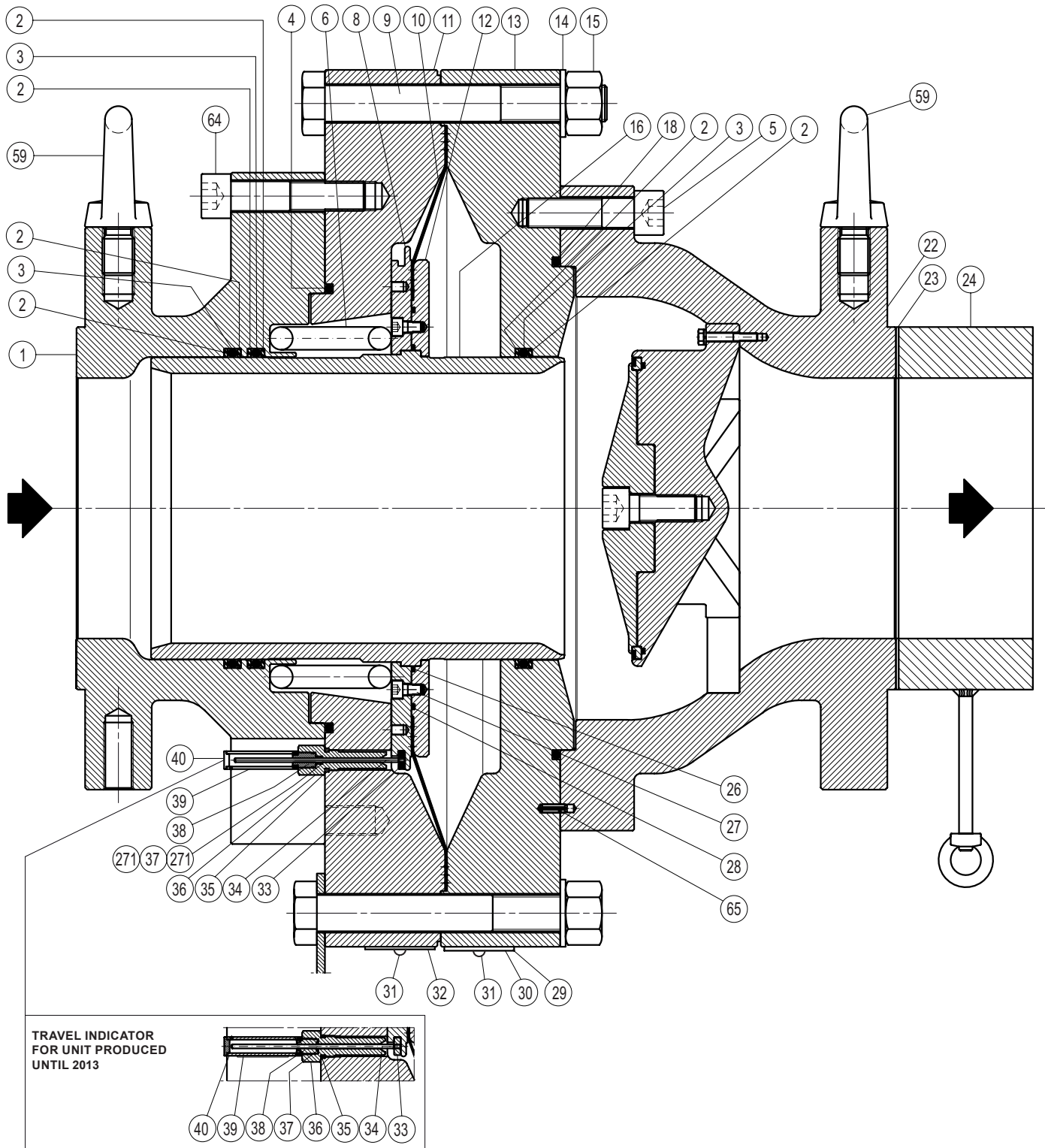

LM/1403

Figure 12. Type FL Regulator DN 200

Type FL

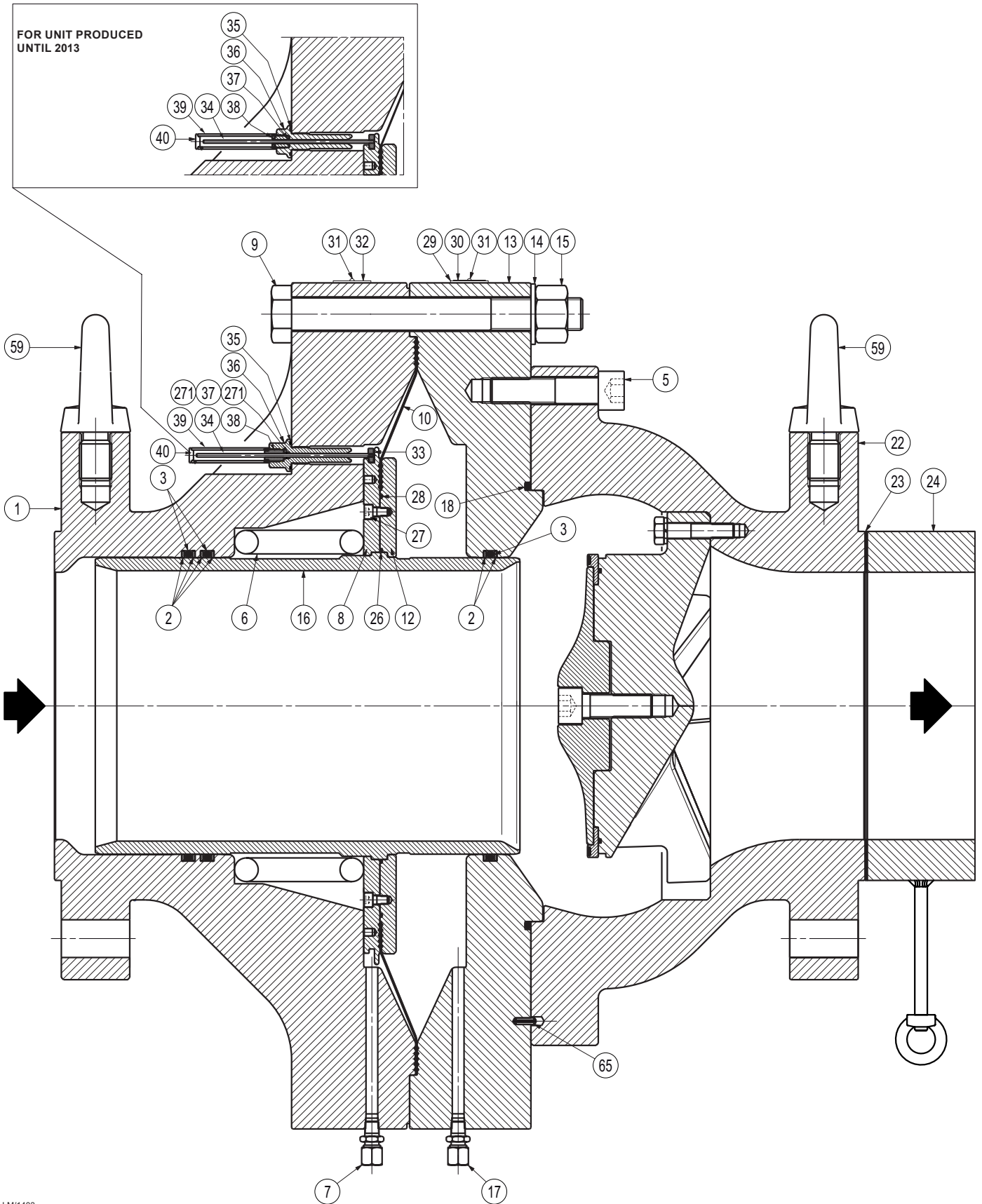
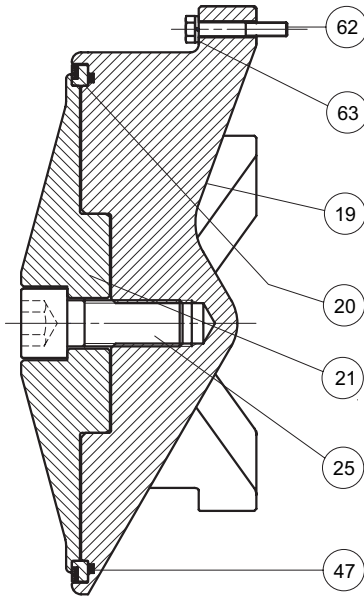
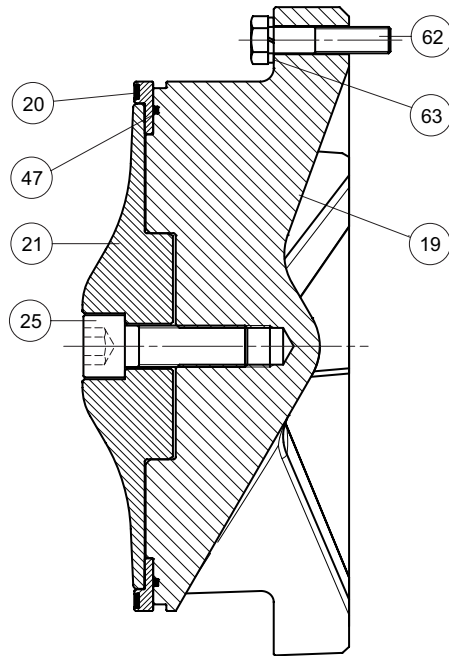

Figure 13. Type FL Regulator DN 250

FL DN 200 WITHOUT SILENCER



FL DN 250 WITHOUT SILENCER



FL DN 200 AND DN 250 WITH SRII SILENCER

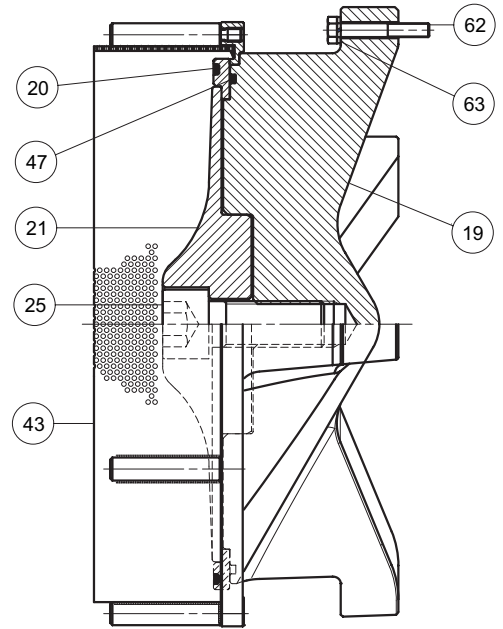

FL DN 200 AND DN 250 WITH POLYURETHANE PAD WITHOUT SILENCER

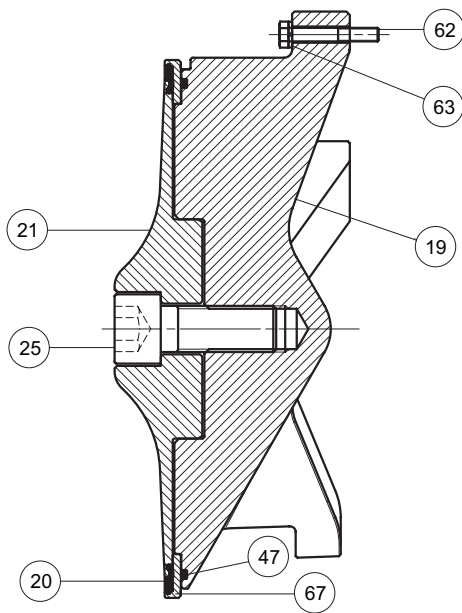

FL DN 200 AND DN 250 WITH POLYURETHANE PAD AND SRII SILENCER

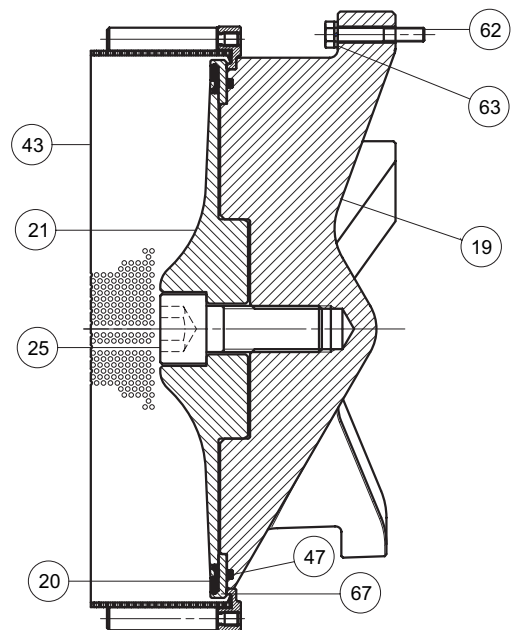

LM/1403

Figure 14. Pad Holder for Type FL Regulator DN 200 and DN 250

Type FL

WIDENED OUTLET FLANGE VERSION

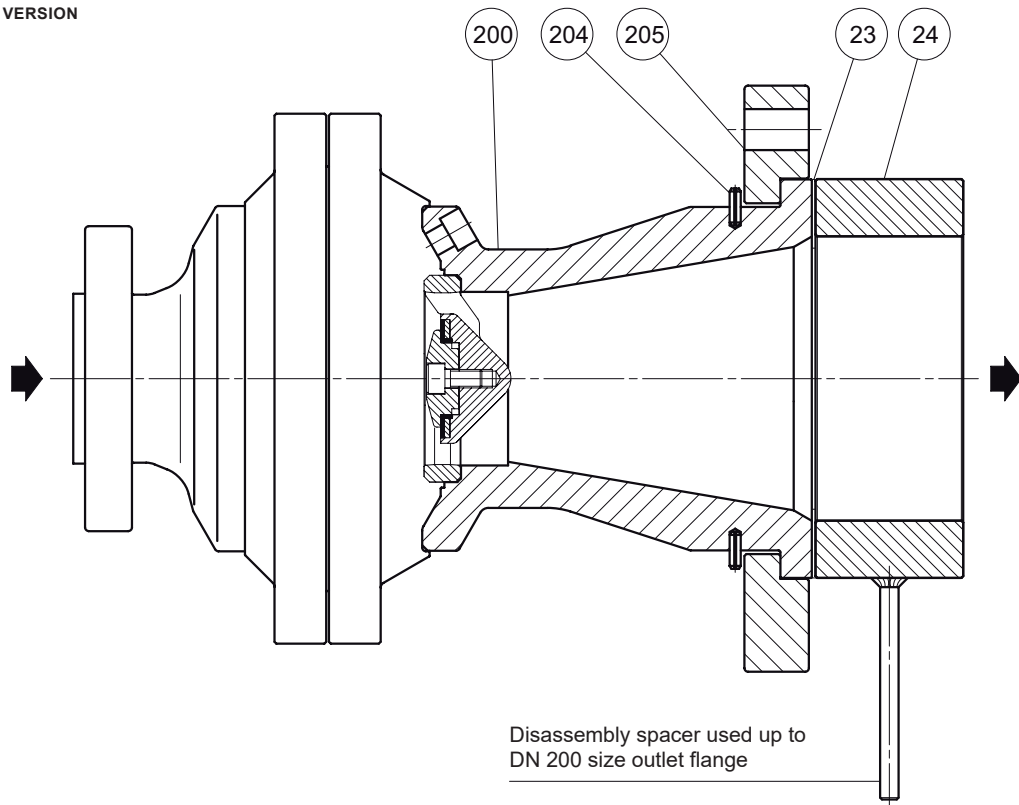

DN 25 TO DN 100 SRS VERSION

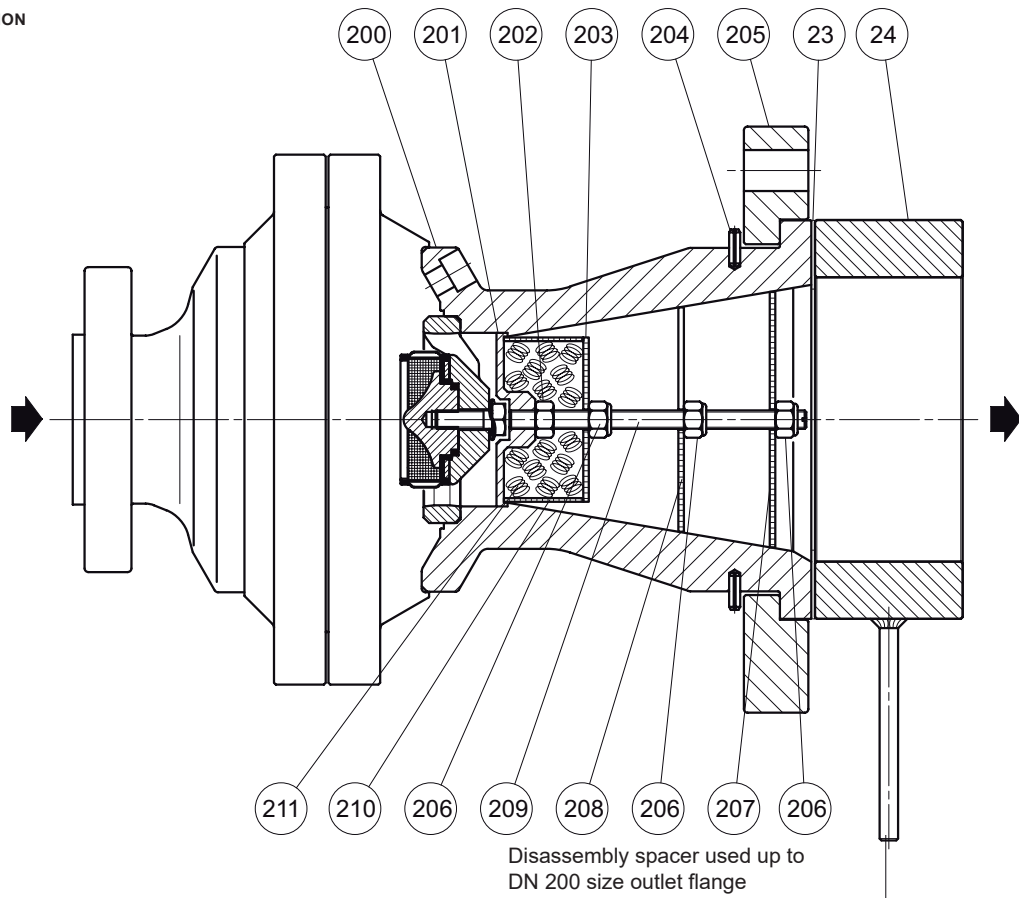

LM/1403

Figure 15. Type FL Regulator Widened Outlet flange, SRS and SRS-R Silencer Versions

DN 25 TO DN 100 SRS-R REINFORCED VERSION

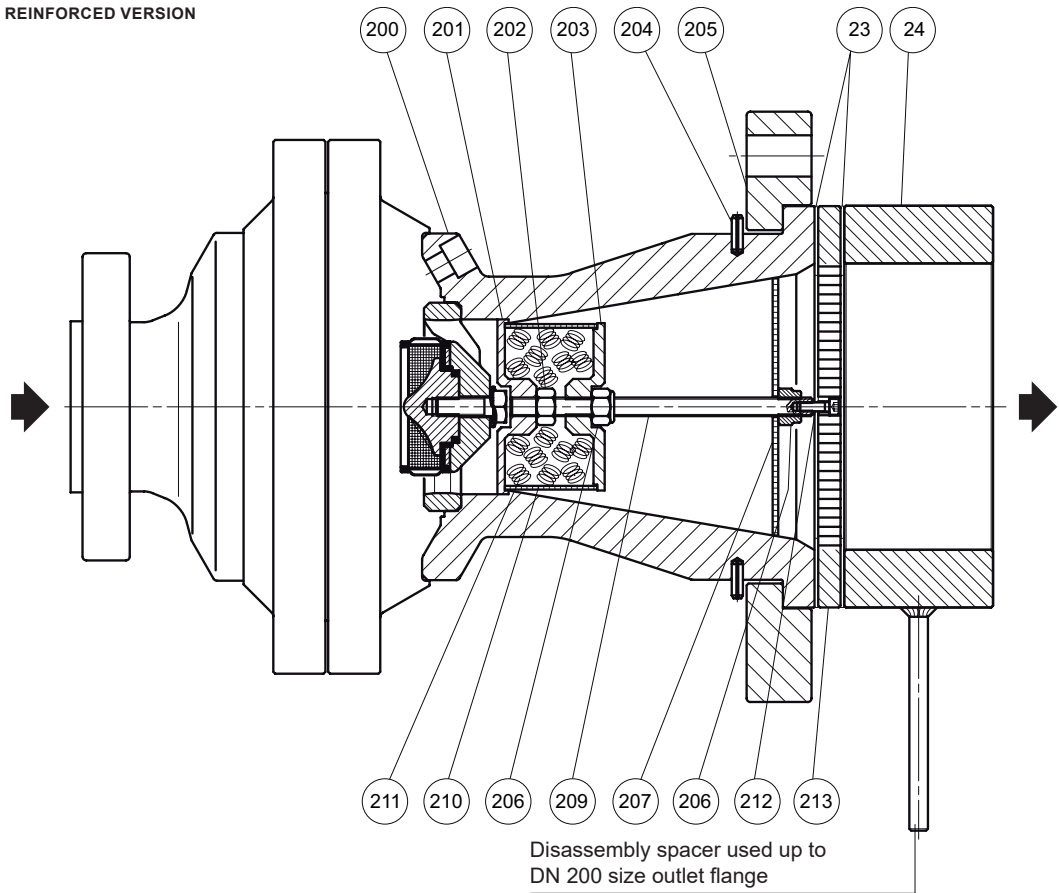

DN 150 SRS VERSION

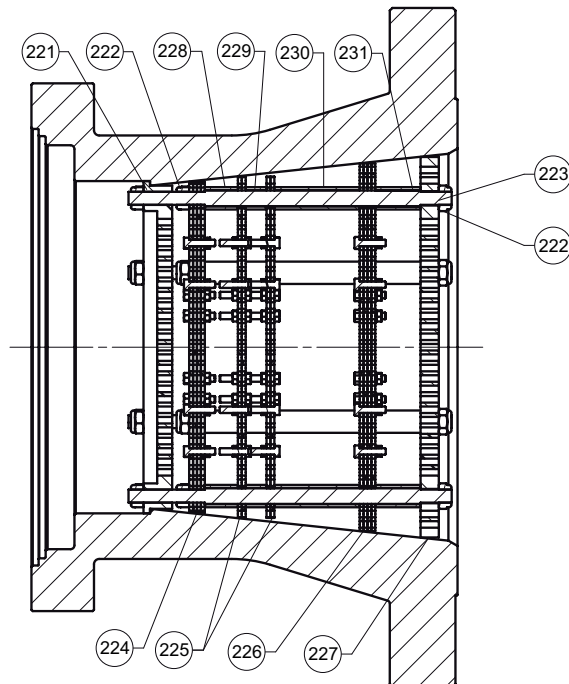

LM/1403

Figure 16. Type FL Regulator Widened Outlet flange, SRS and SRS-R Silencer Versions (continued)

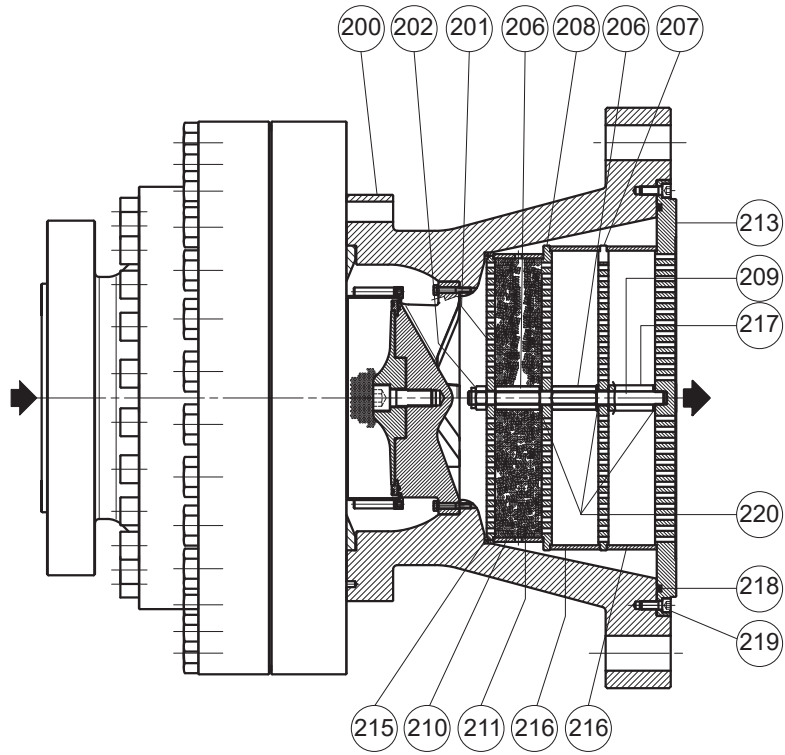

LM/1403

Figure 15a. Type FL/200 Regulator SRSII Version

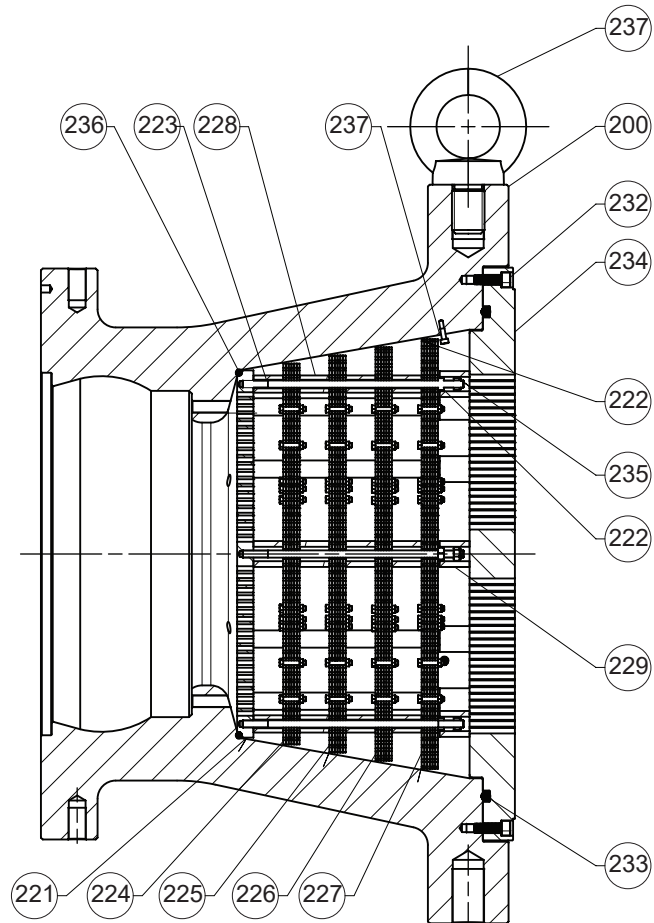

ERAA45283_AB

Figure 16b. Type FL/250 Regulator SRSII Version

MFL-SR/ - MFL-BP-SR/25/40/50/65/80/100 VERSIONS

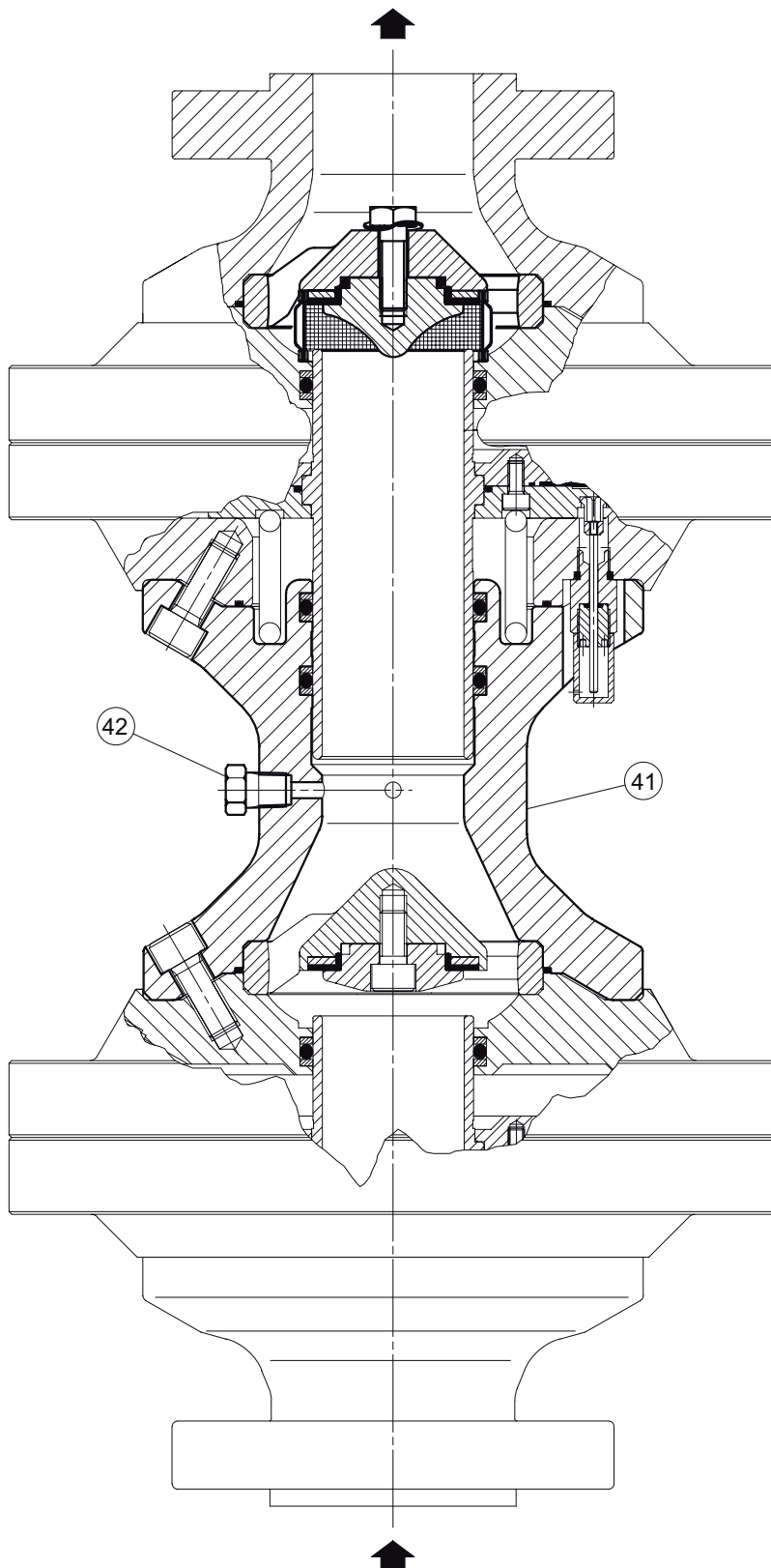

LM/1403

Figure 17. Type MFL Regulator

Type FL

FL-BP/150 DETAIL

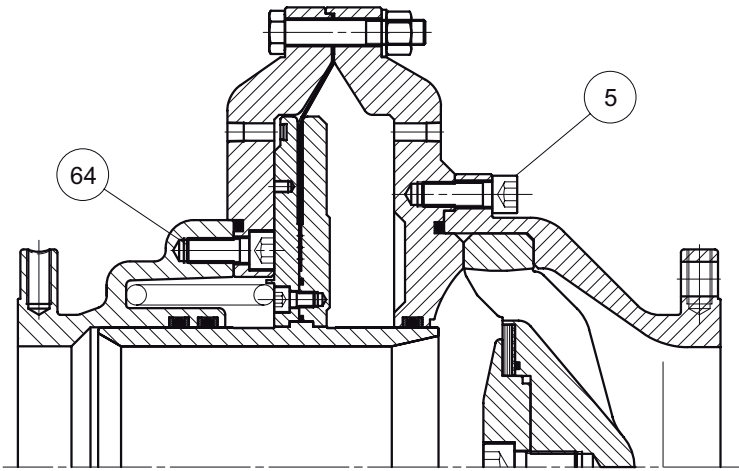

FL/150 ANSI 300-600 DETAIL

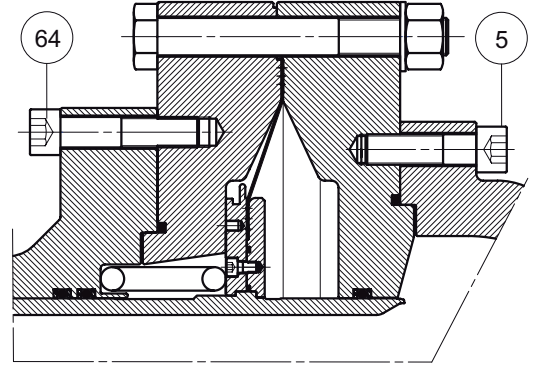

FL/150 ANSI 300-600 DETAIL

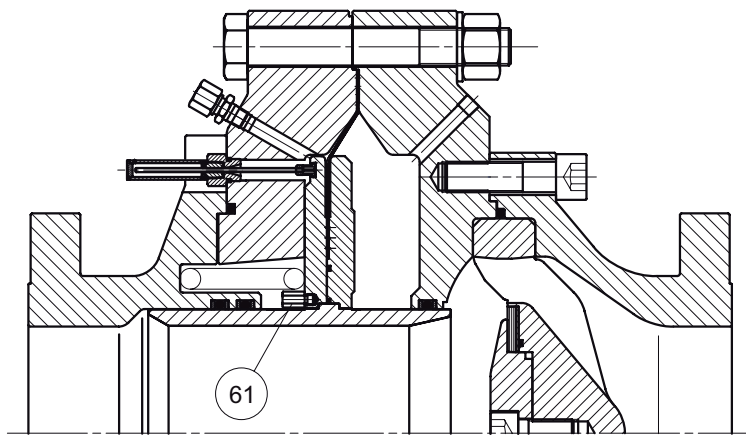

FL-BP/150 DETAIL

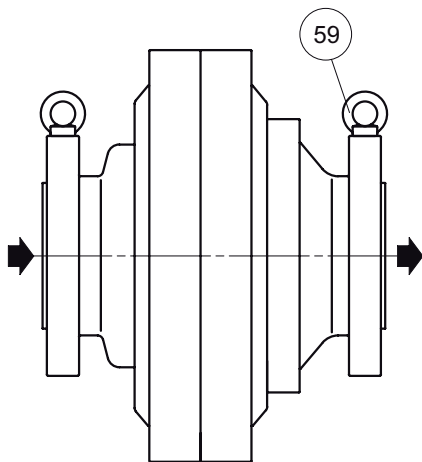

FL/150 FL-BP/150 "SRS" VERSION DETAIL

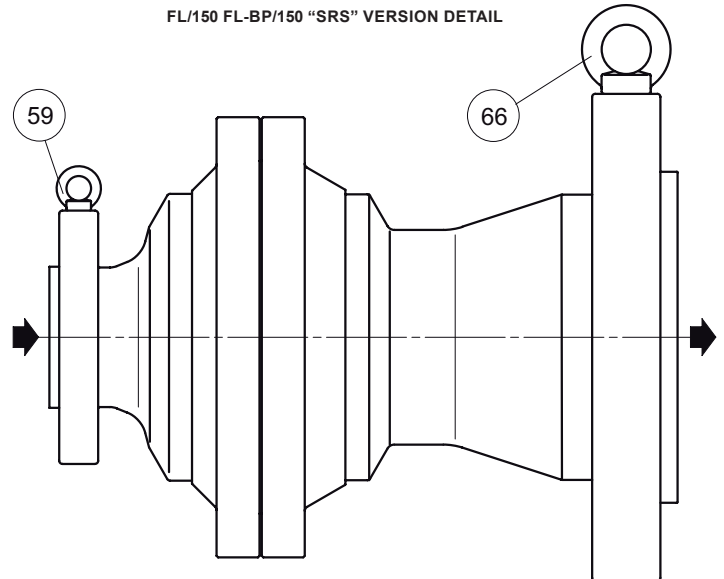

LM/1403

Figure 18. Type FL Regulator DN 150 Various Versions

**FL-BP/ WITH TRANSDUCER VERSION
FOR DOWNSTREAM PRESSURE UP TO 5 BAR**

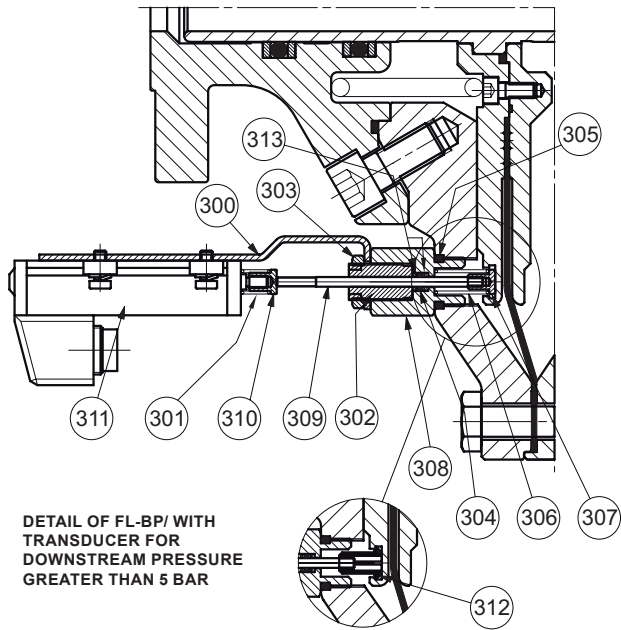

FL/ FL-BP/ WITH PROXIMITY SWITCH VERSION

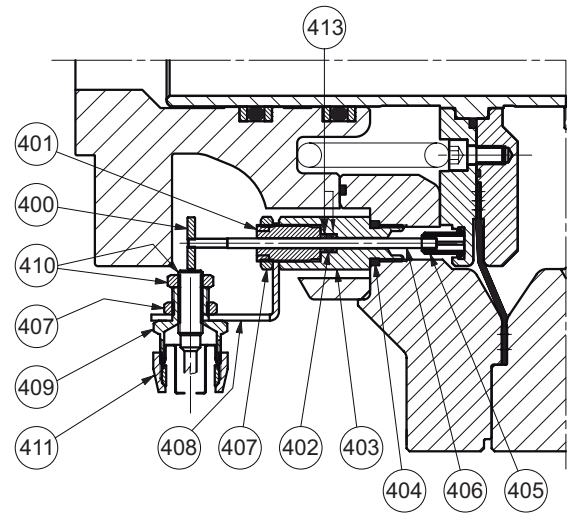

FL/ WITH TRANSDUCER VERSION

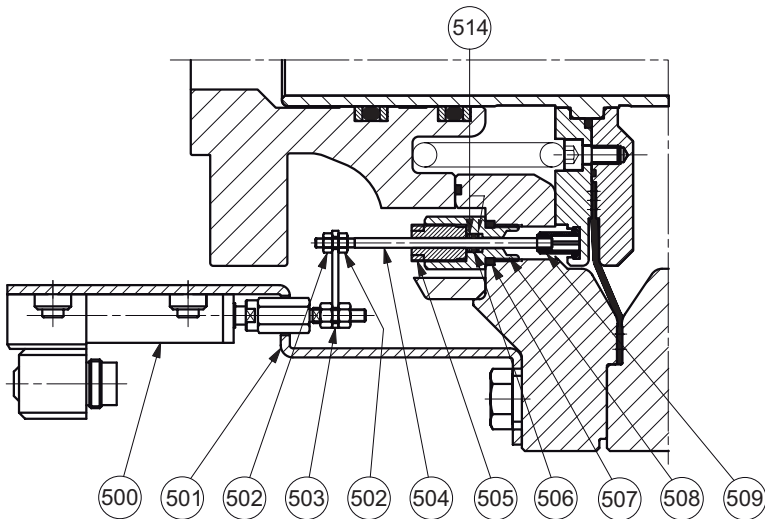

FL/ WITH MICROSWITCH VERSION

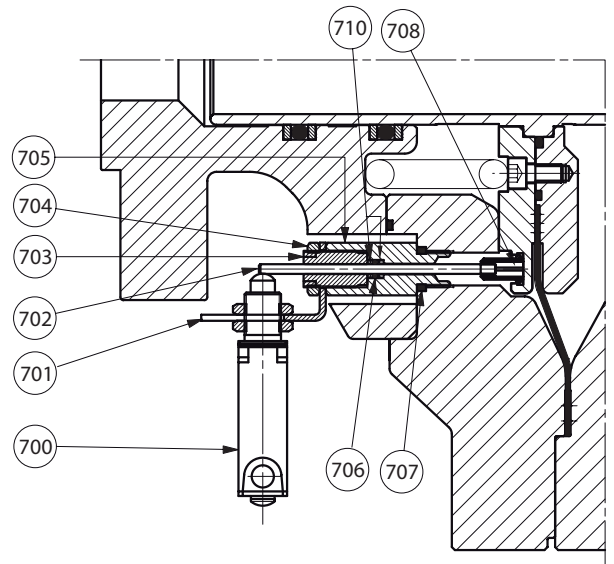
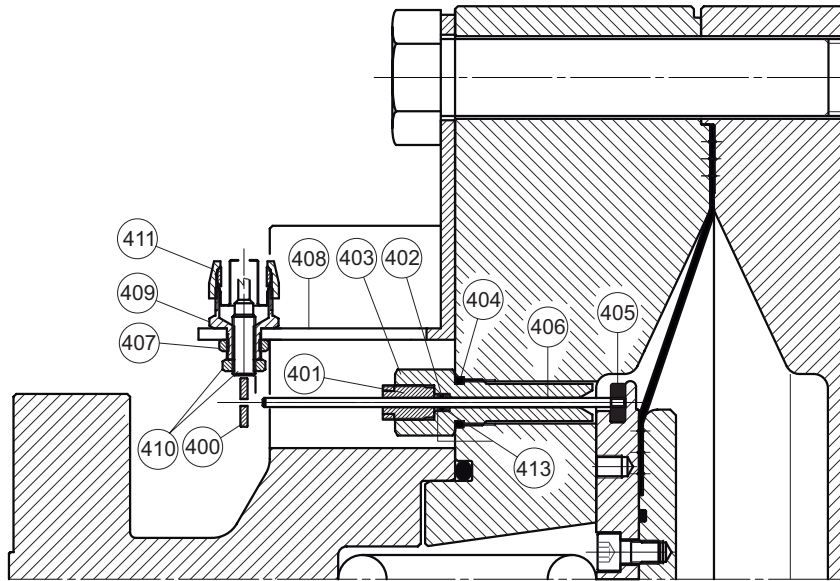

Figure 19. Type FL Regulator DN 25 to DN 150 with Transducer, Proximity and Microswitch

Type FL

FL/200 WITH PROXIMITY VERSION



FL/200 WITH TRANSDUCER VERSION

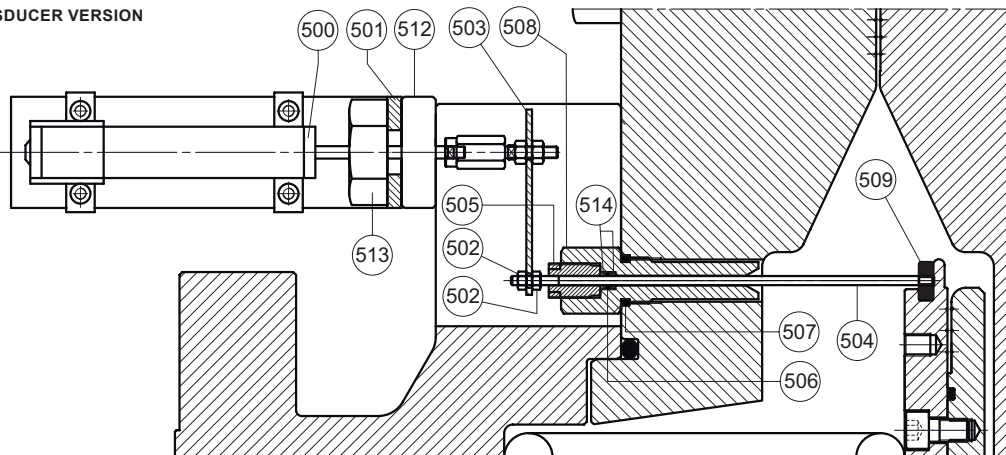

FL/200 WITH MICROSWITCH VERSION

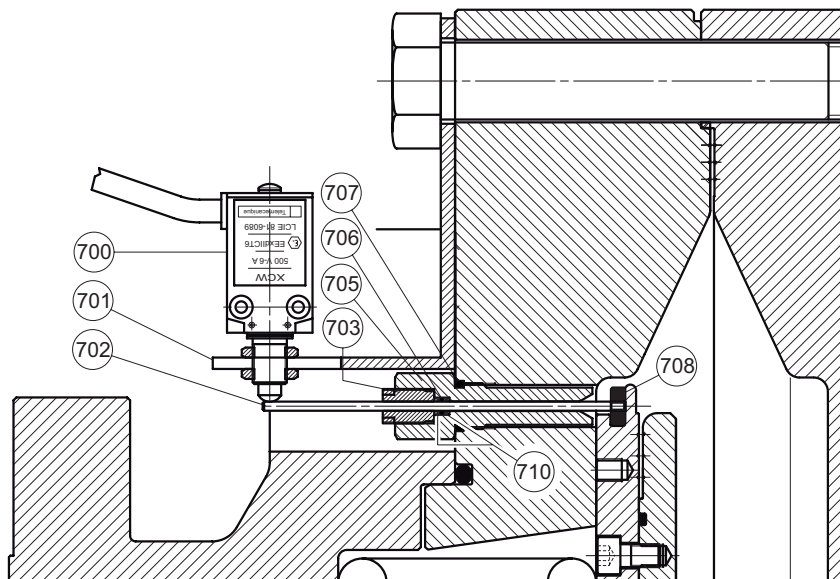

LM/1403

Figure 20. Type FL Regulator DN 200 with Transducer, Proximity and Microswitch

FL/250 WITH PROXIMITY VERSION

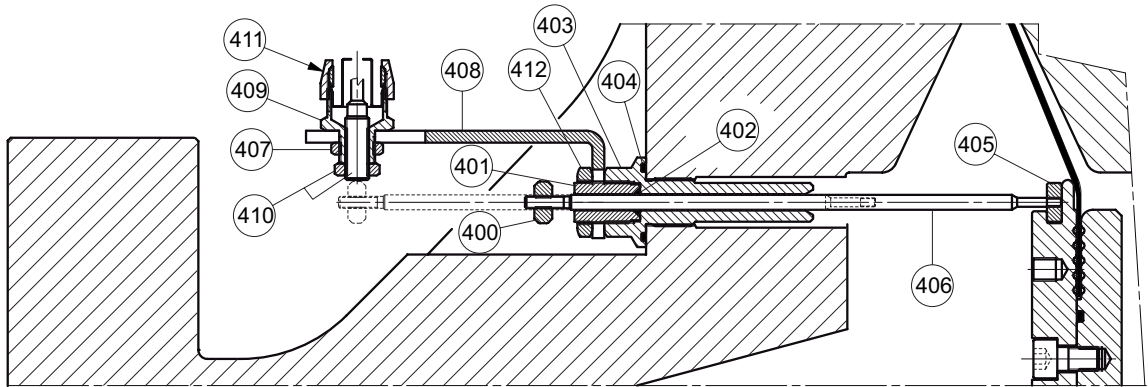

FL/250 WITH TRANSDUCER VERSION

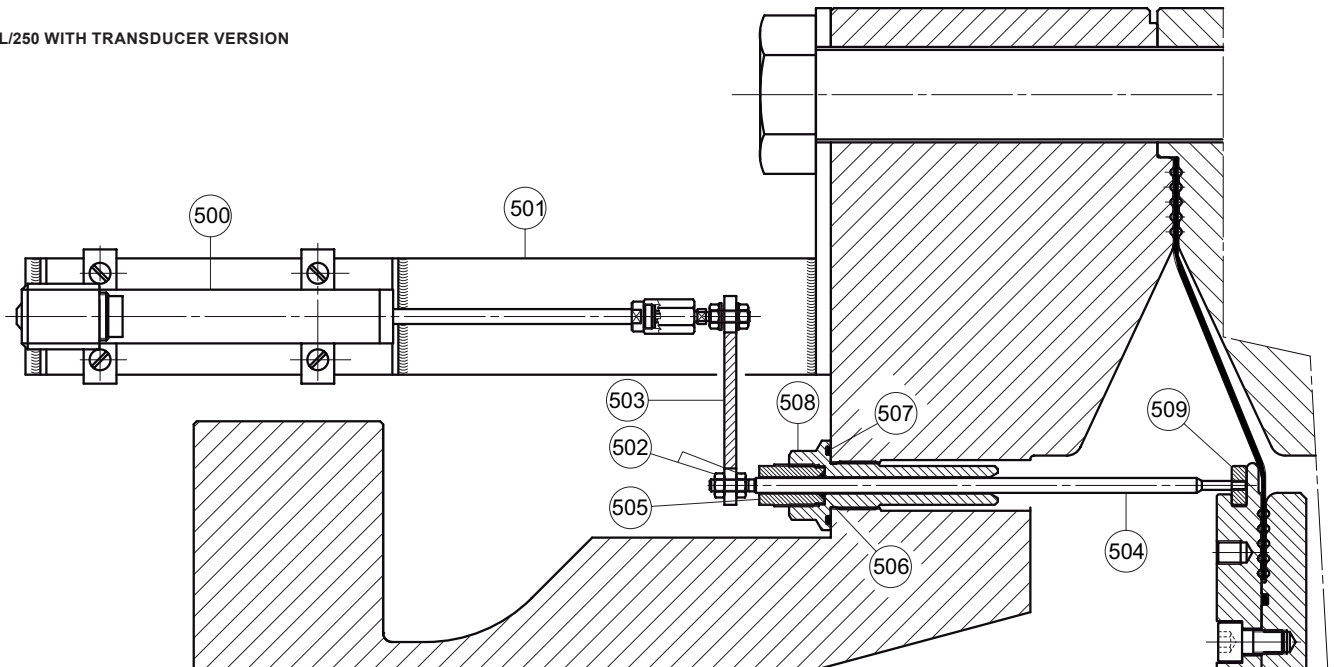

FL/250 WITH MICROSWITCH VERSION

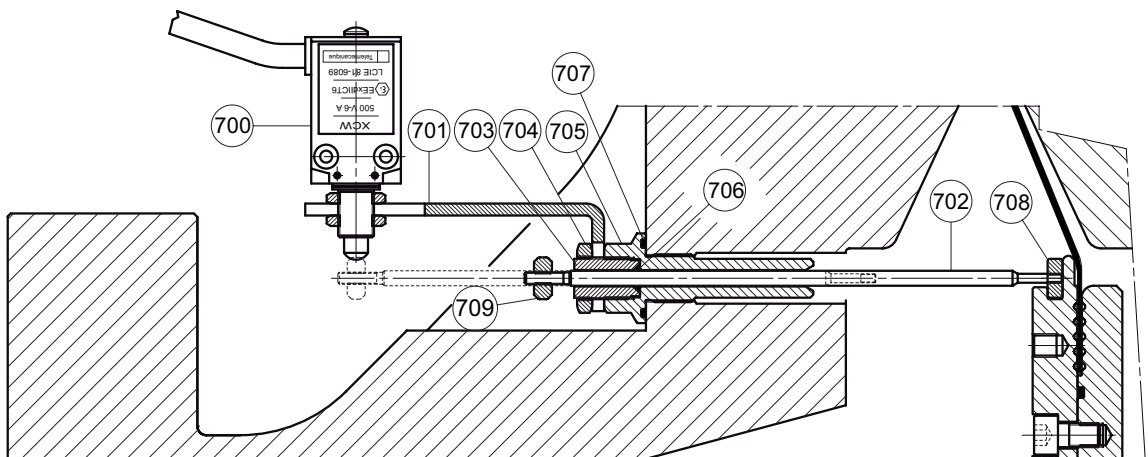

LM/1403

Figure 21. Type FL Regulator DN 250 with Transducer, Proximity and Microswitch

Type FL

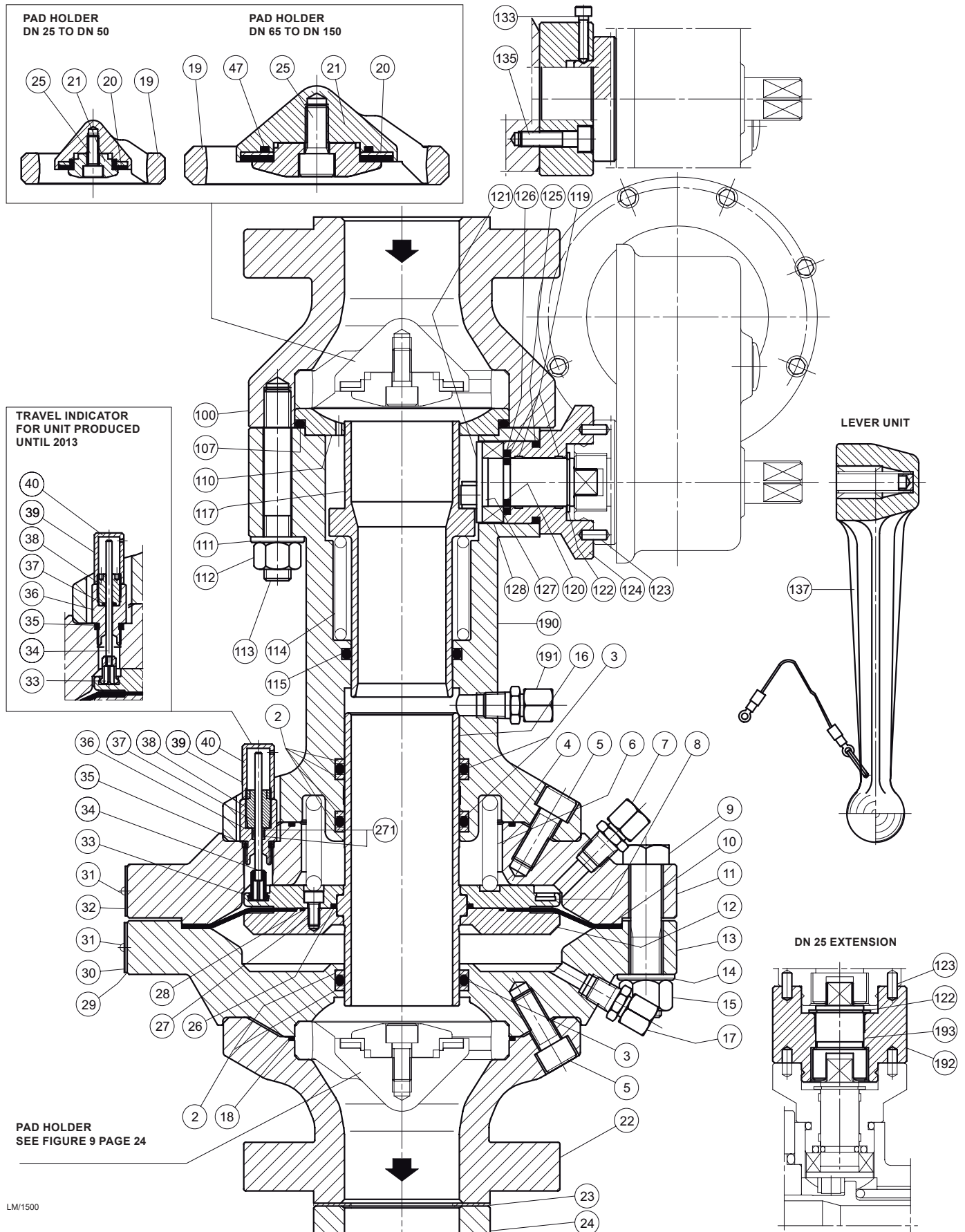
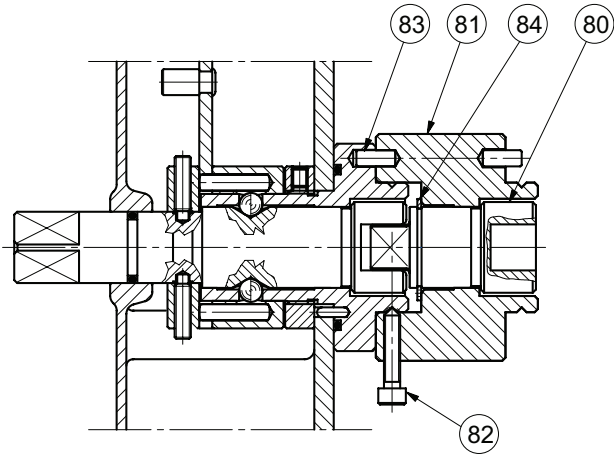
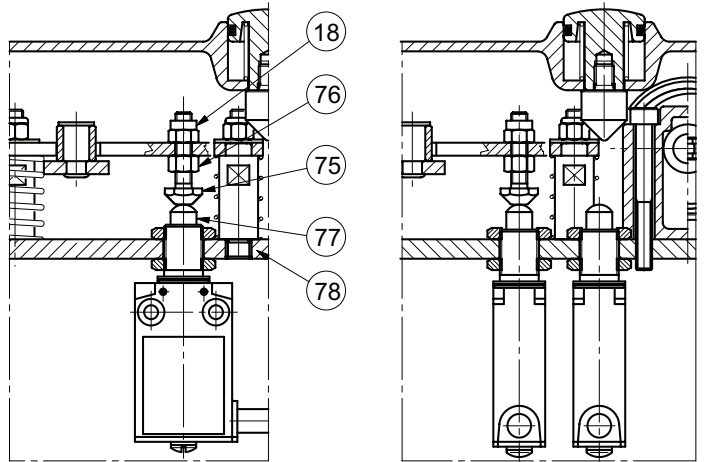

Figure 22. Type BFL Regulator with Slam-shut

DETAIL EXTENSION FOR OS/80X WITH SINGLE OR DOUBLE MICROSWITCH



DETAIL OS/80X WITH SINGLE AND DOUBLE MICROSWITCH



DETAIL OS/80X WITH SINGLE AND DOUBLE PROXIMITY

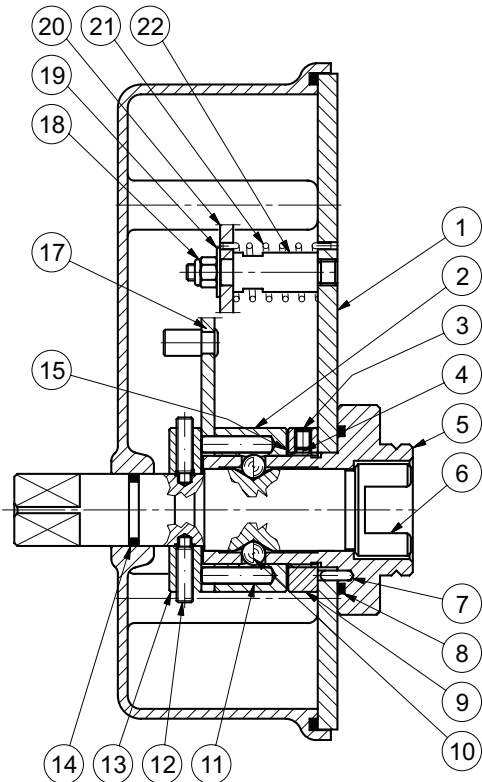
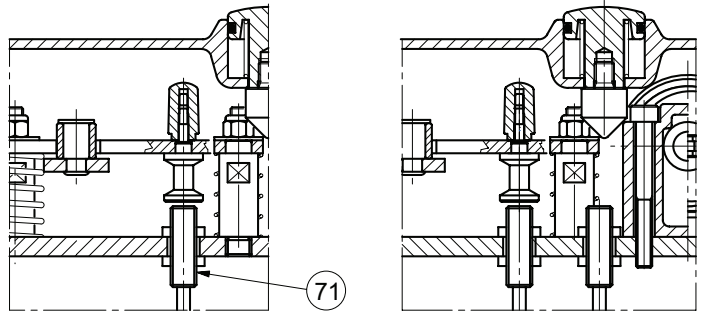

SECTION C-C

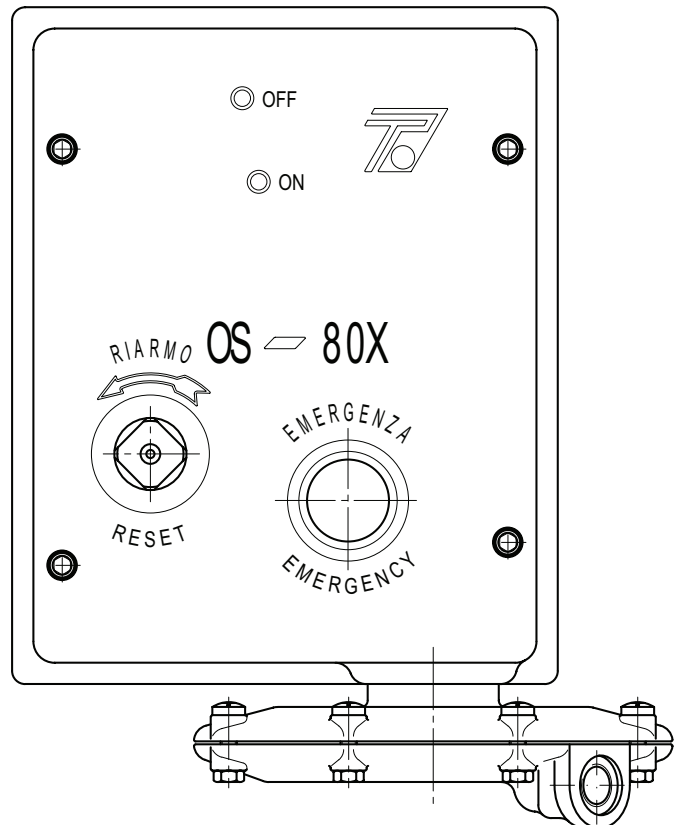

LM/1989

Figure 23. OS/80X Series Slam-Shut Controller (Standard Version)

Type FL

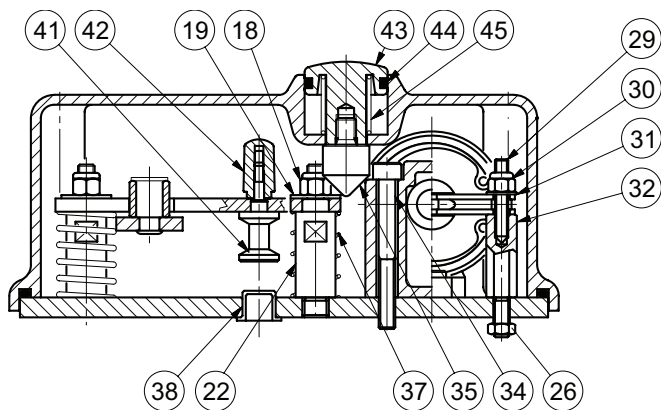

SECTION A-A

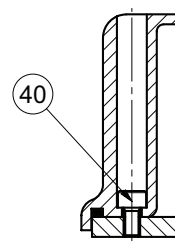

SECTION D-D

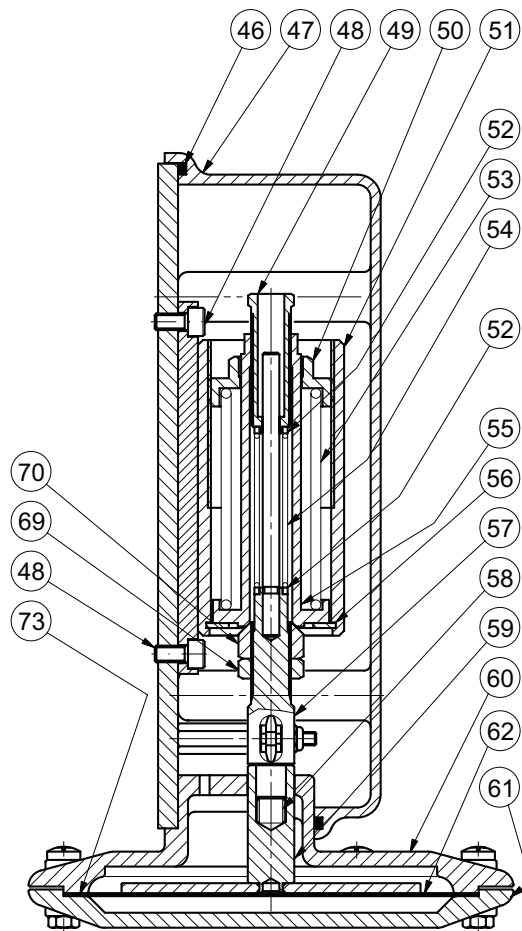
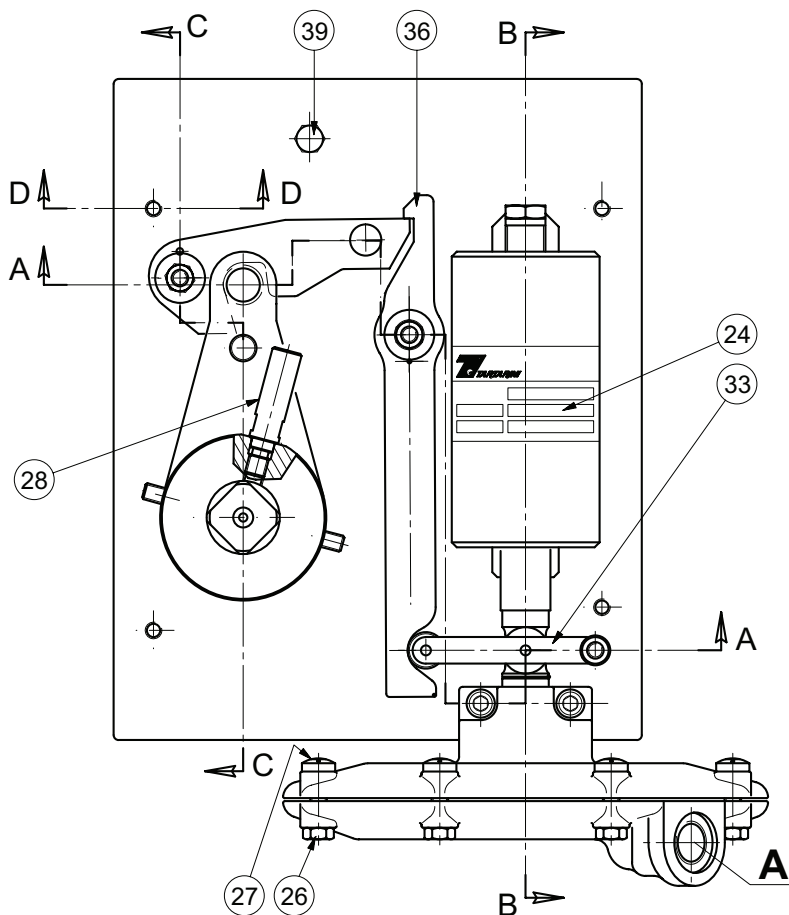

SECTION B-B

Figure 23. OS/80X Series Slam-Shut Controller (Standard Version) (continued)

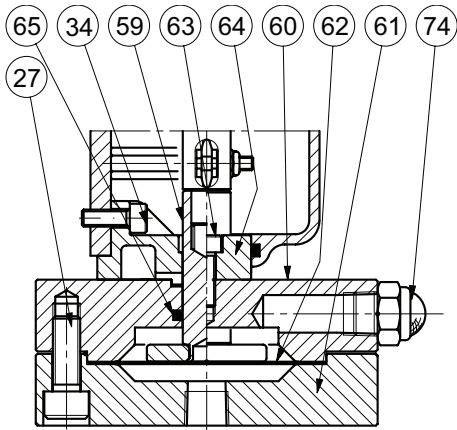

TYPE OS/80X-APA-D

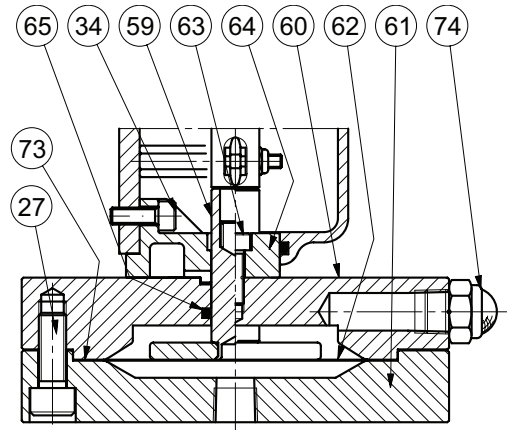

TYPE OS/80X-MPA-D

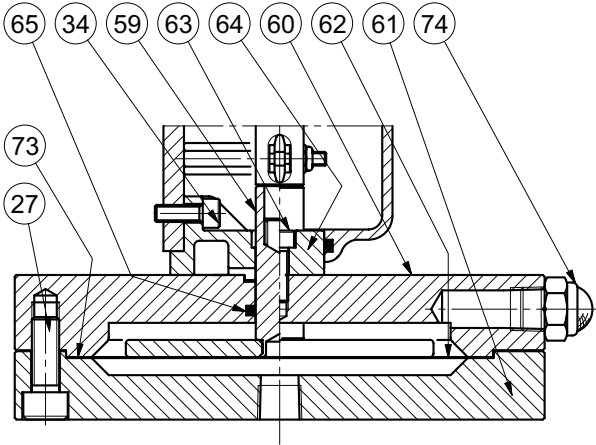

TYPE OS/80X-BPA-D

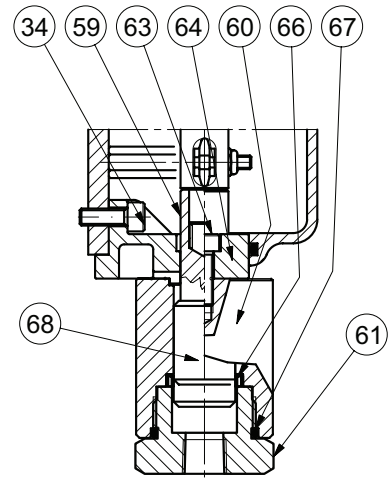

TYPE OS/84X

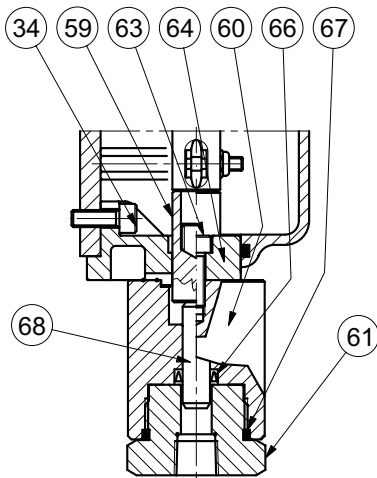

TYPE OS/88X DETAIL

LM/1389

Figure 23. OS/80X Series Slam-Shut Controller (Standard Version) (continued)

Type FL

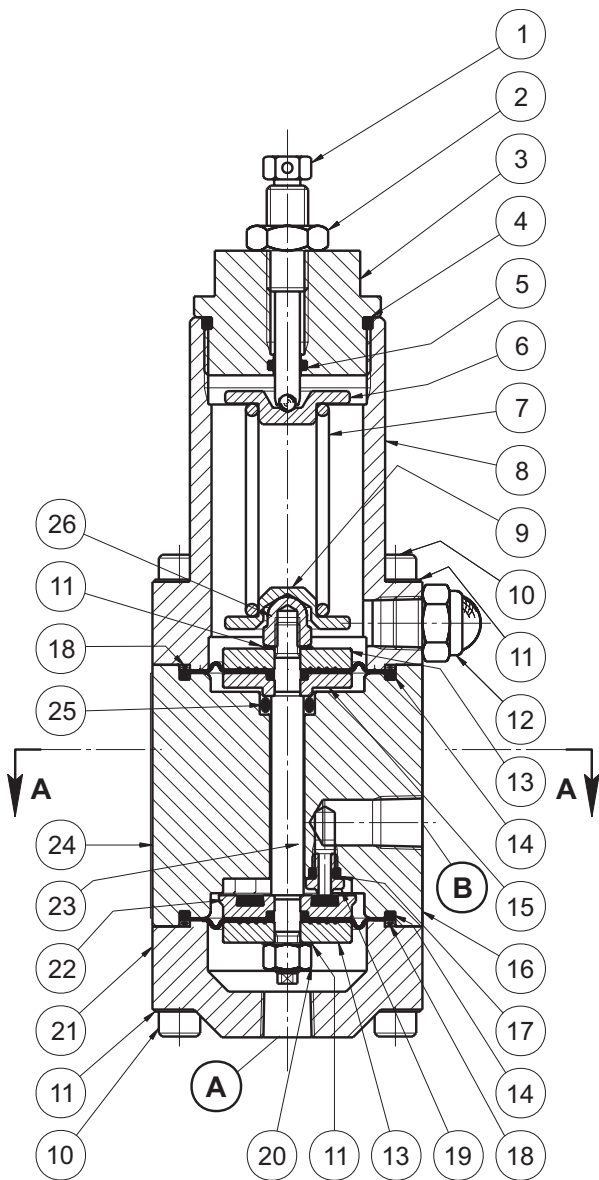

TYPE PRX/120 AND PRX/125

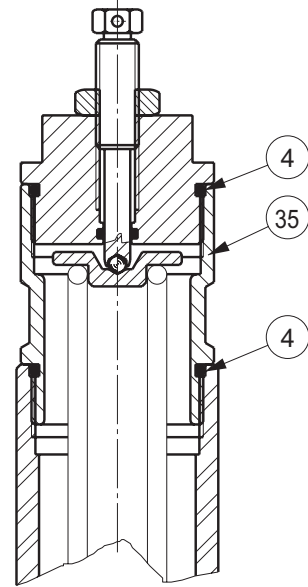

AP VERSION

Type PRX/120 Connections

CODE	CONNECTIONS
A	Downstream of the regulator
B	Pilot feed
S	Downstream or safe area
L	To the regulator (loading pressure)

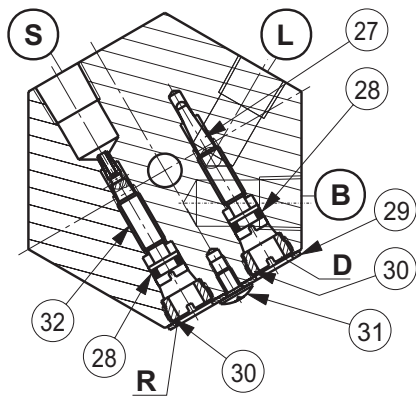

TYPE PRX/120 VERSION - SECTION A-A

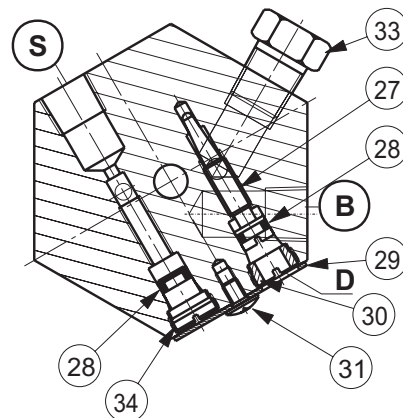

TYPE PRX/125 VERSION - SECTION A-A

LM/1390

Figure 24. Type PRX/120 and PRX/125 Pilots

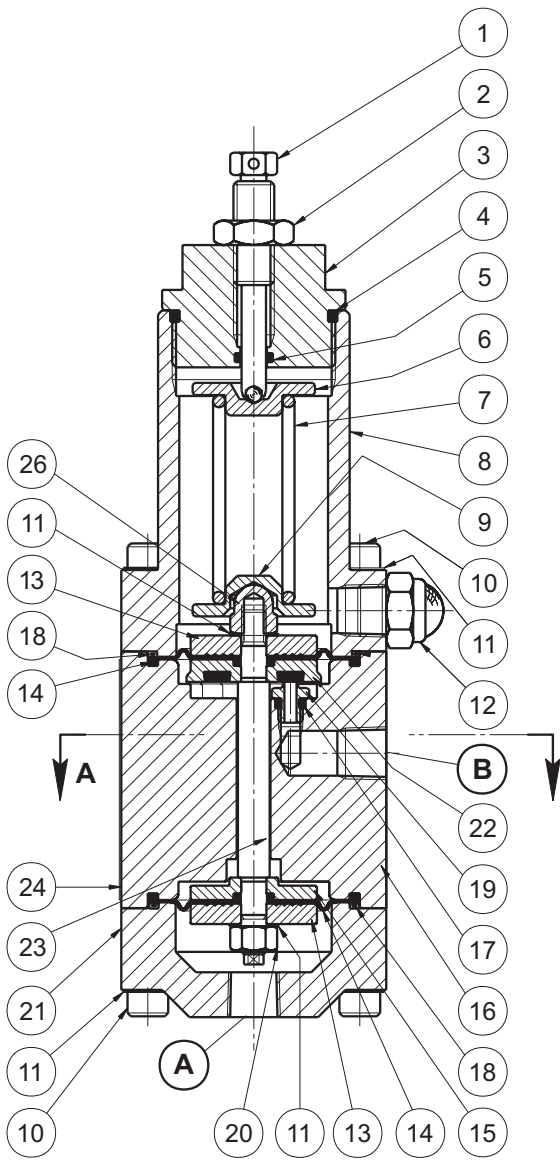

TYPE PRX/131

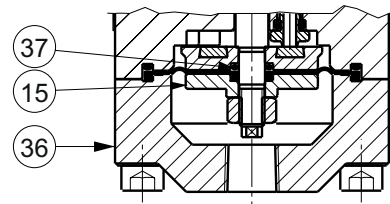

TYPE PRX/181-PN

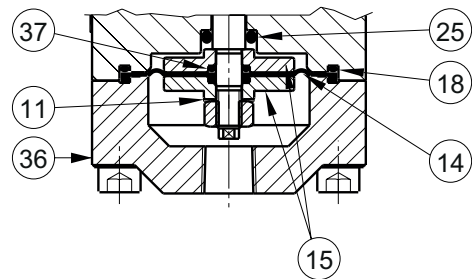

TYPE PRX/182-PN

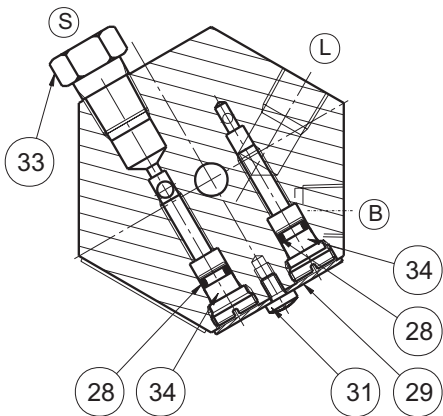

SECTION A-A

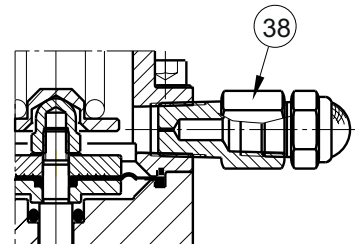

TYPES PRX/181-PN AND PRX/182-PN

Figure 25. Type PRX/131 Pilot

Figure 26. Types PRX/181-PN and PRX/182-PN Pilots

Type FL

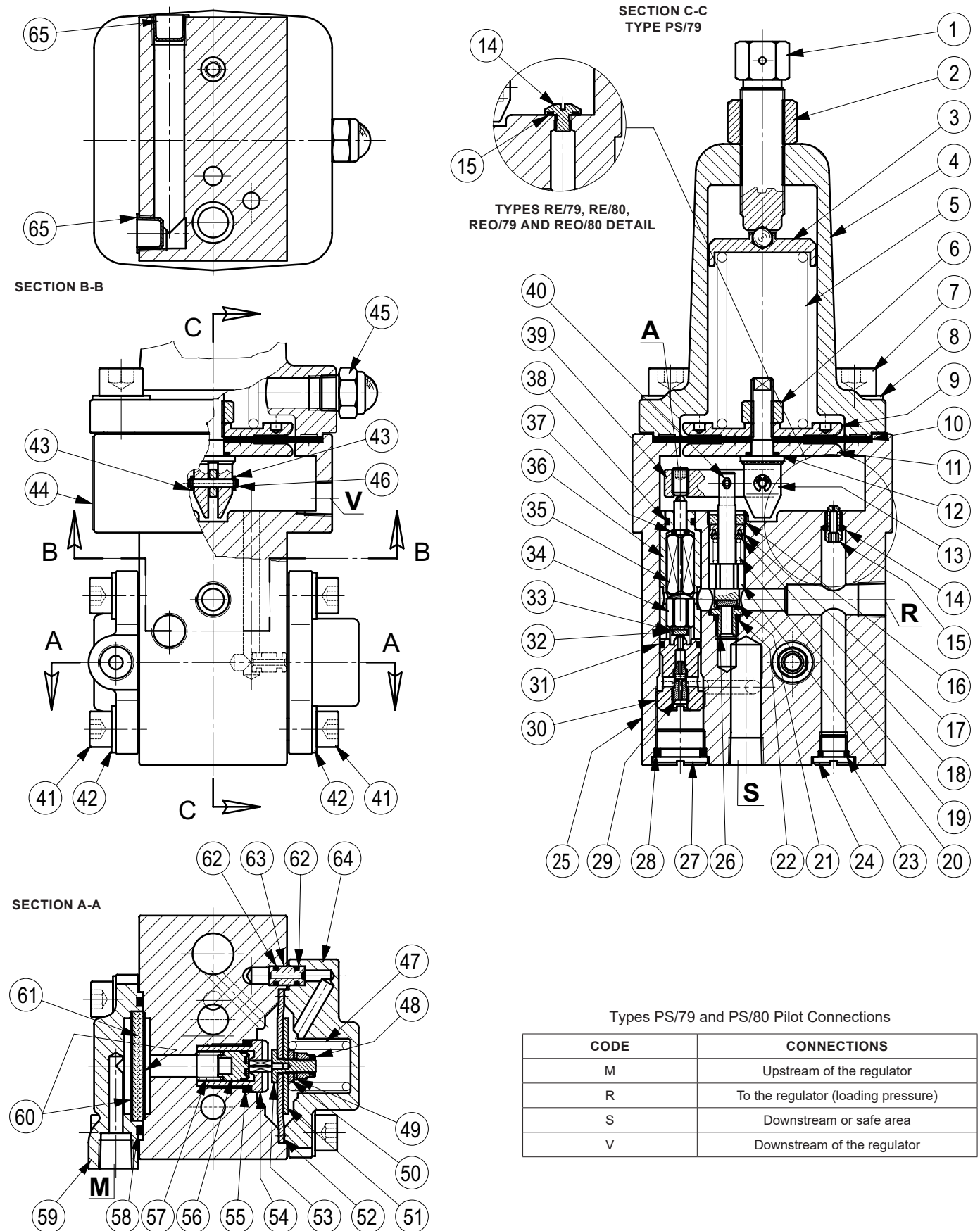

LM/1346

Figure 27. Types PS/79, PS/80, RE/79 and RE/80 Pilots

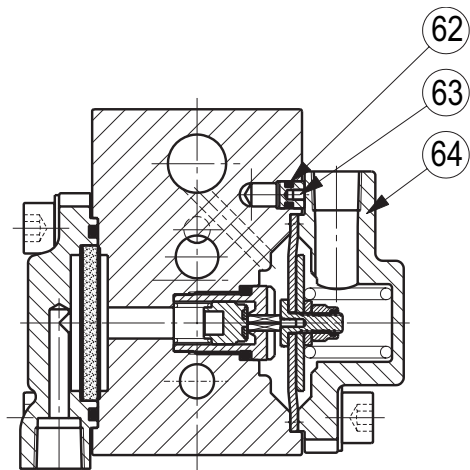

TYPES REO/79 AND REO/80

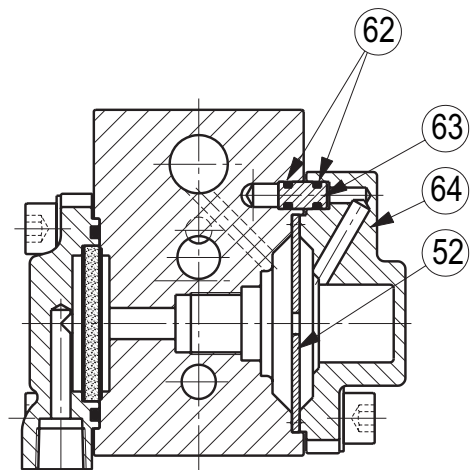

TYPES PSO/79 AND PSO/80

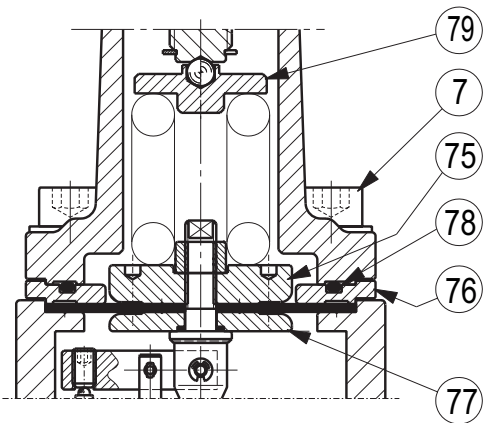

TYPE PS/79-AP

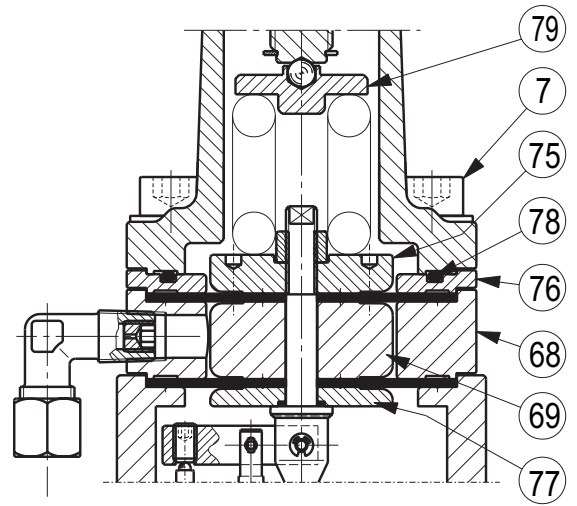

TYPE PS/80-AP

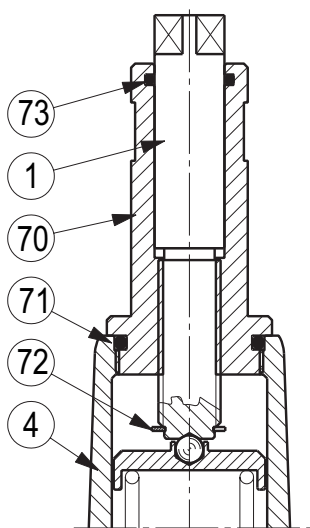

TYPES PS/79-D AND PS/80-D

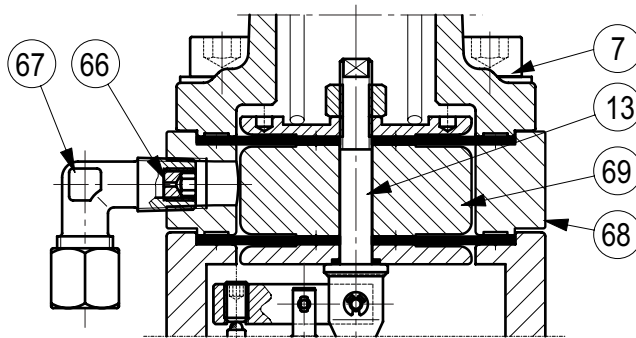

TYPE PS/80

Figure 27. Types PS/79, PS/80, RE/79 and RE/80 Pilots (continued)

Type FL

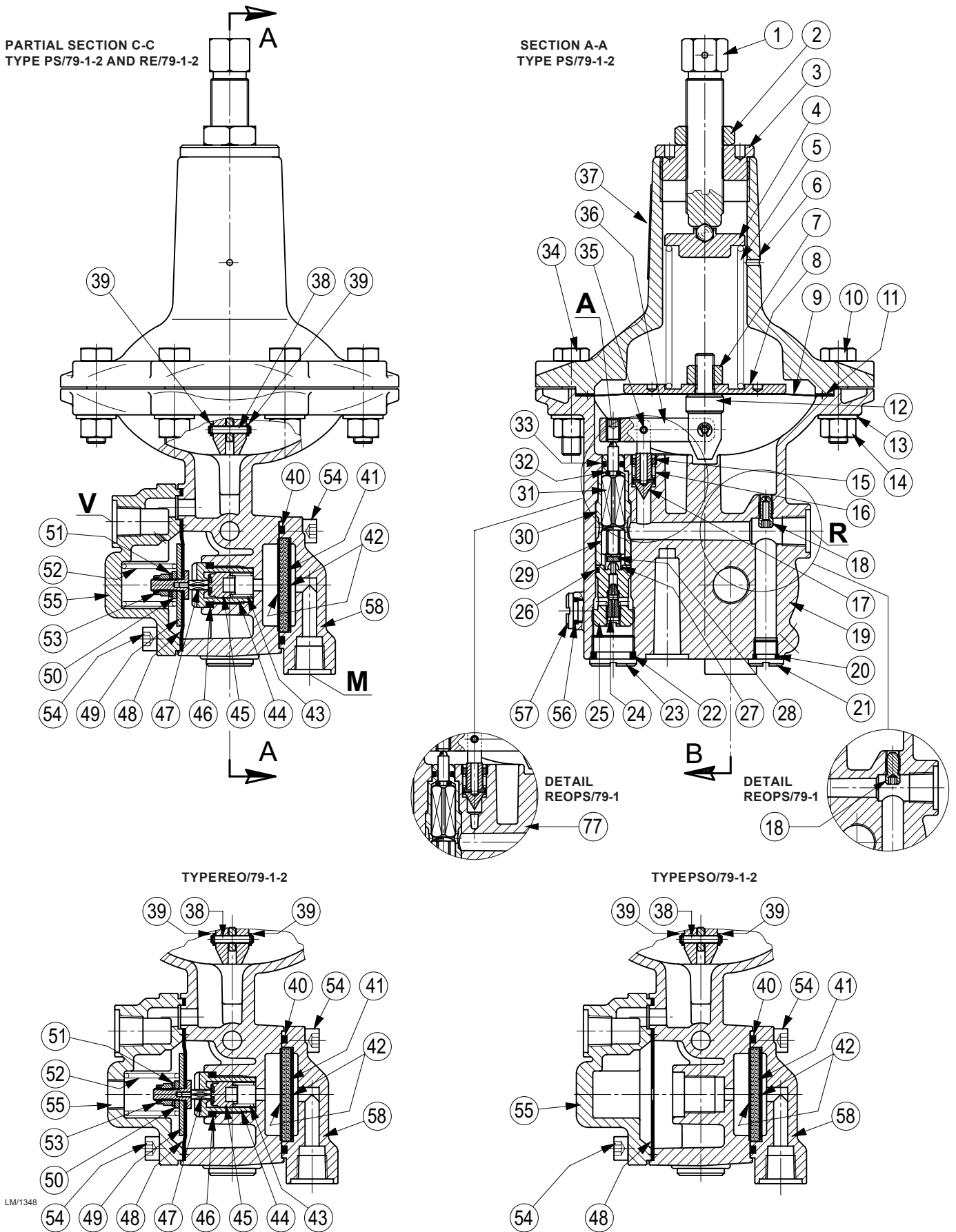
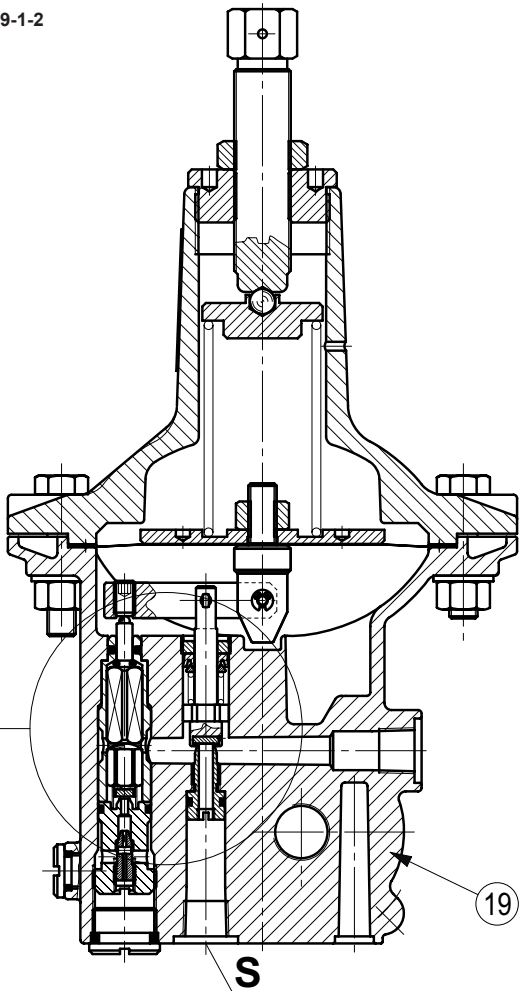
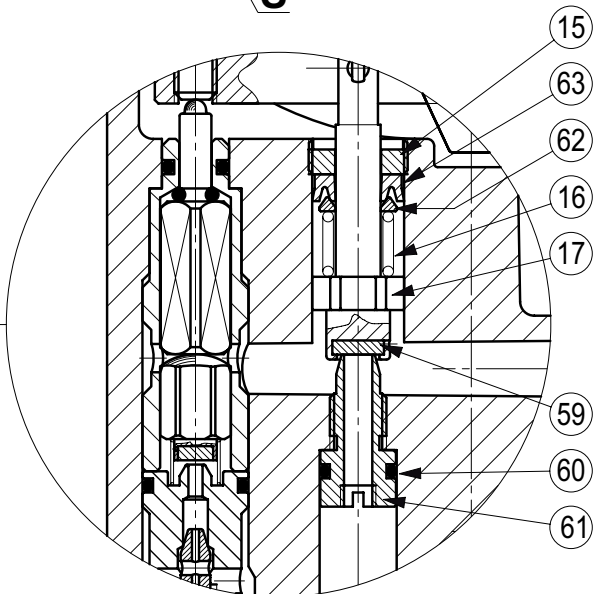
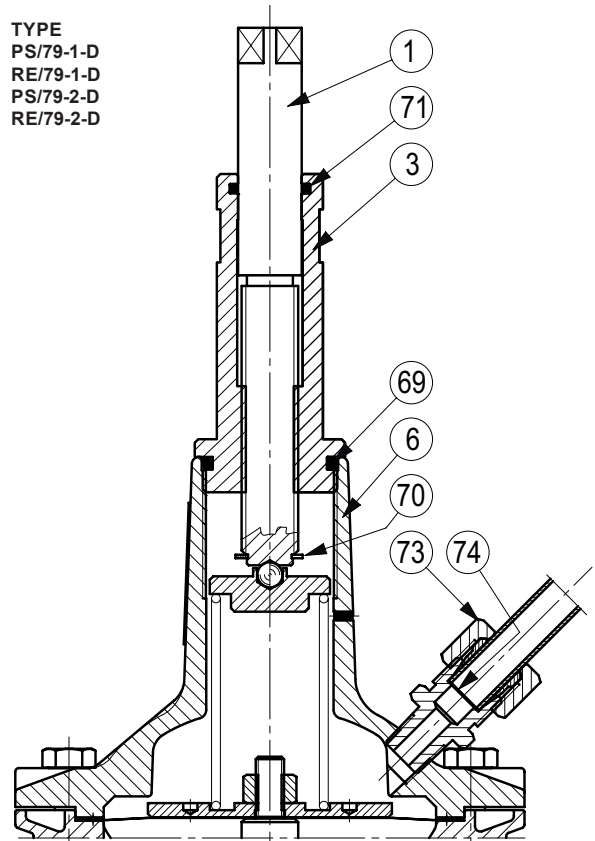

Figure 28. Types PS/79-1, PS/79-2, RE/79-1 and RE/79-2 Pilots

TYPE RE/79-1-2



TYPE
PS/79-1-D
RE/79-1-D
PS/79-2-D
RE/79-2-D



Types PS/79-1 and PS/79-2 Pilot Connections

CODE	CONNECTIONS
M	Upstream of the regulator
R	To the regulator (loading pressure)
S	Downstream or safe area
V	Downstream of the regulator

Figure 28. Types PS/79-1, PS/79-2, RE/79-1 and RE/79-2 Pilots (continued)

Type FL

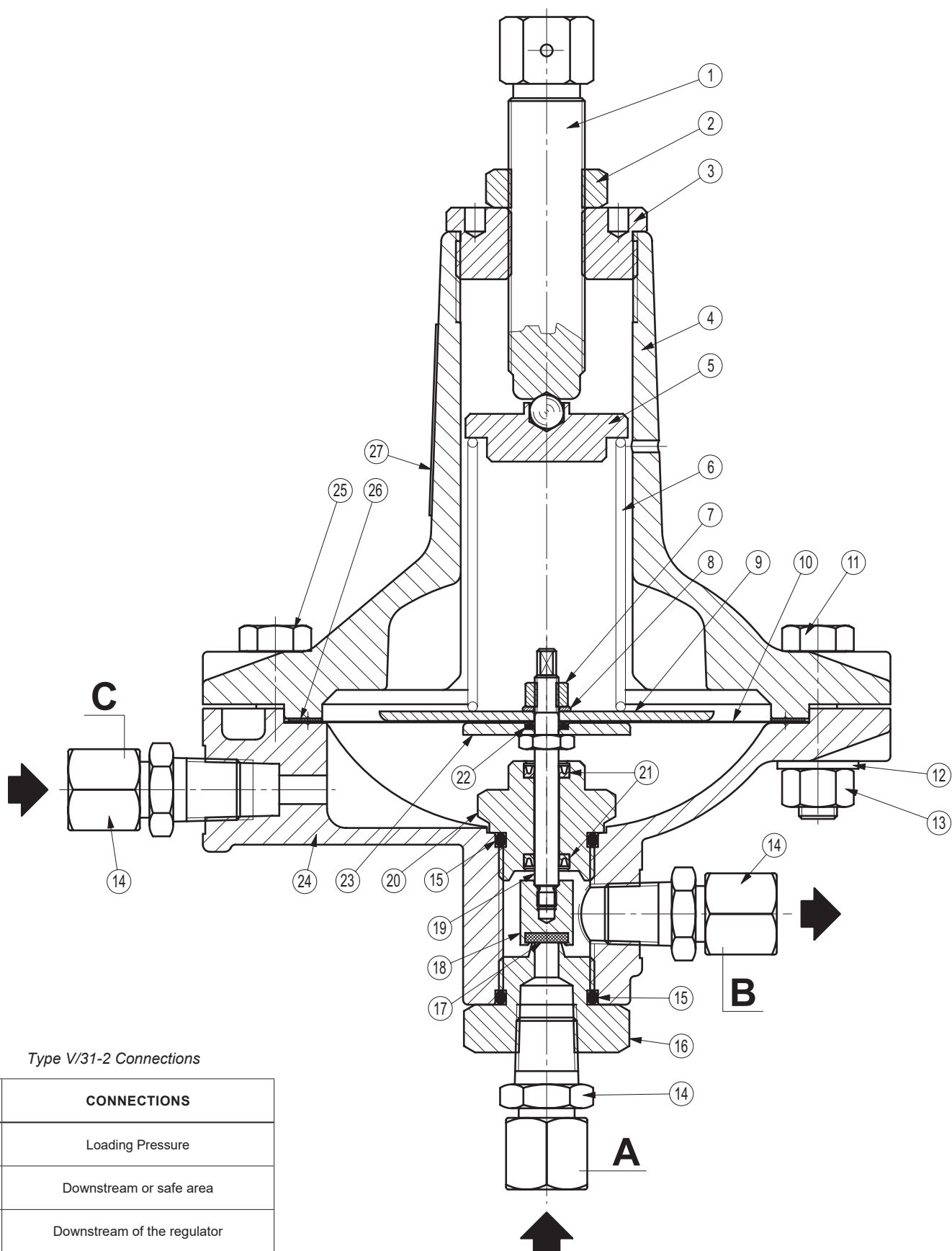
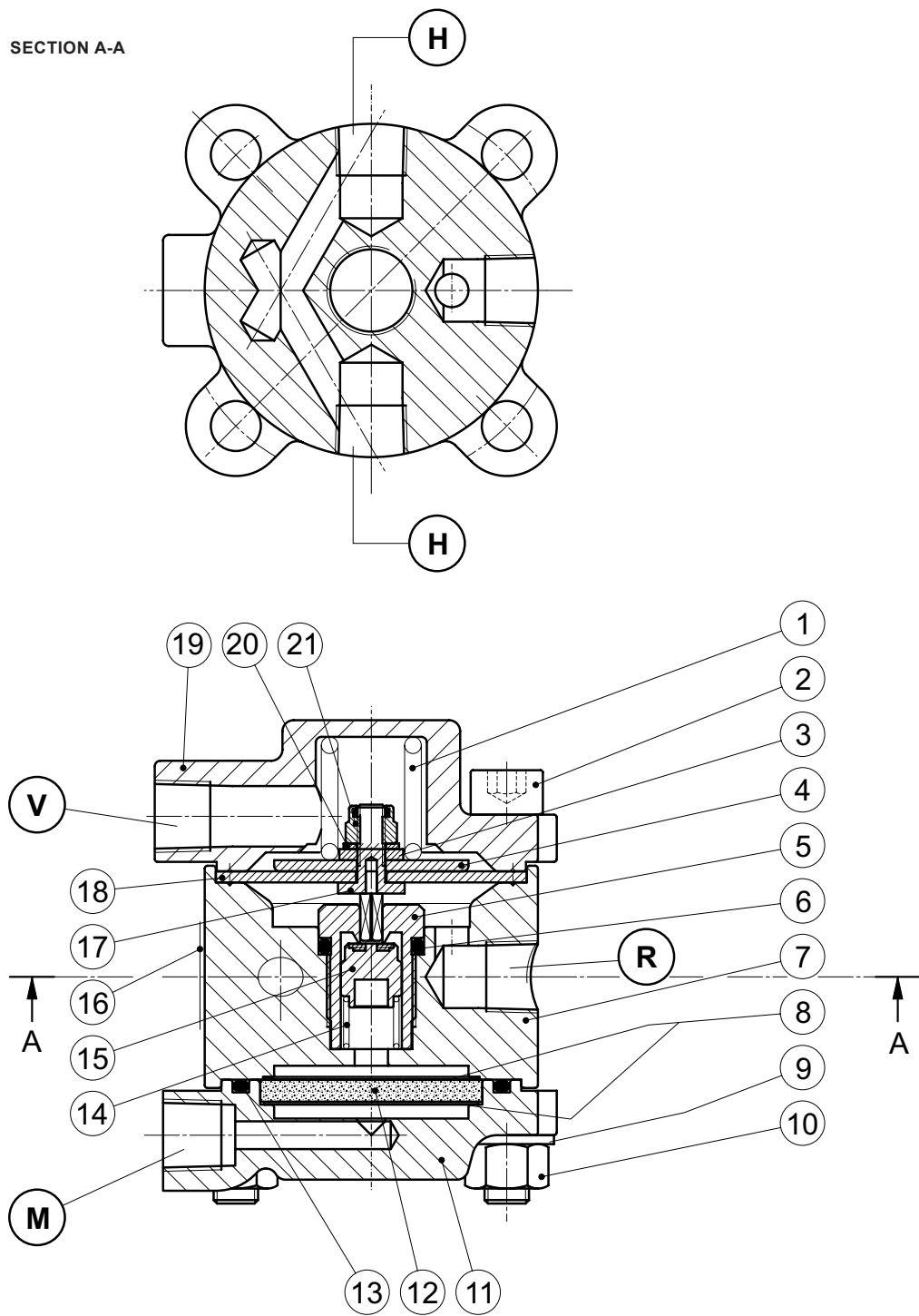

Figure 29. Type V/31-2 Booster Valve



Type SA/2 Connections

CODE	CONNECTIONS
H	Water inlet/outlet
M	Upstream of the regulator
R	To the pilot feed
V	Downstream of the regulator

LM/1162

Figure 30. Type SA/2 Stabilizer Filter

Type FL

✉ Webadmin.Regulators@emerson.com

🔍 Tartarini-NaturalGas.com

📘 Facebook.com/EmersonAutomationSolutions

🌐 LinkedIn.com/company/emerson-automation-solutions

🐦 Twitter.com/emr_automation

Emerson Automation Solutions

Americas

McKinney, Texas 75070 USA
T +1 800 558 5853
+1 972 548 3574

Europe

Bologna 40013, Italy
T +39 051 419 0611

Asia Pacific

Singapore 128461, Singapore
T +65 6777 8211

Middle East and Africa

Dubai, United Arab Emirates
T +971 4 811 8100

D103652X012 © 2016, 2023 Emerson Process Management Regulator Technologies, Inc. All rights reserved. 04/23.

The Emerson logo is a trademark and service mark of Emerson Electric Co. All other marks are the property of their prospective owners. Tartarini™ is a mark owned by one of the companies in the Emerson Automation Solutions business unit of Emerson Electric Co.

The contents of this publication are presented for informational purposes only, and while every effort has been made to ensure their accuracy, they are not to be construed as warranties or guarantees, express or implied, regarding the products or services described herein or their use or applicability. All sales are governed by our terms and conditions, which are available upon request. We reserve the right to modify or improve the designs or specifications of such products at any time without notice.

Emerson Process Management Regulator Technologies, Inc does not assume responsibility for the selection, use or maintenance of any product. Responsibility for proper selection, use and maintenance of any Emerson Process Management Regulator Technologies, Inc. product remains solely with the purchaser.

Emerson Process Management s.r.l

Emerson Automation Solutions - Stabilimento di/Site of: Castel Maggiore - Bologna
Sede Legale/Legal Entity: Piazza Meda 5, 20121 Milano, Italy
Sede Amministrativa/Administrative Headquarters: OMT Tartarini, Via Clodoveo Bonazzi 43,
40013 Castel Maggiore (Bologna), Italy
C.F. - P.I. e R.I. di MI 13186130152 - REA di MI/n.1622916
Direz. e Coord. (art. 2497 bis CC): EMERSON ELECTRIC CO. St. Louis (USA) Socio Unico

