

PRESSURE REGULATORS

Type M



M Regulators

M/ Series Pressure Regulator

Their technical and operational features make the MN/ Series spring-loaded regulators the choice of preference in those applications requiring sudden changes in capacity or where gas shutoff is solenoid-controlled as with domestic or industrial burners.

This product has been designed to be used with fuel gases of 1st and 2nd family according to EN 437, and with other non aggressive and non fuel gases. For any other gases, other than natural gas, please contact your local sales agent.

Main features:

- ***Fail Open regulator***
- ***Counterbalanced valve***
- ***Wide pressure regulation range***
- ***Full seal at zero flow***
- ***Easy maintenance***
- ***Optional minimum and/or maximum pressure slam-shut device***

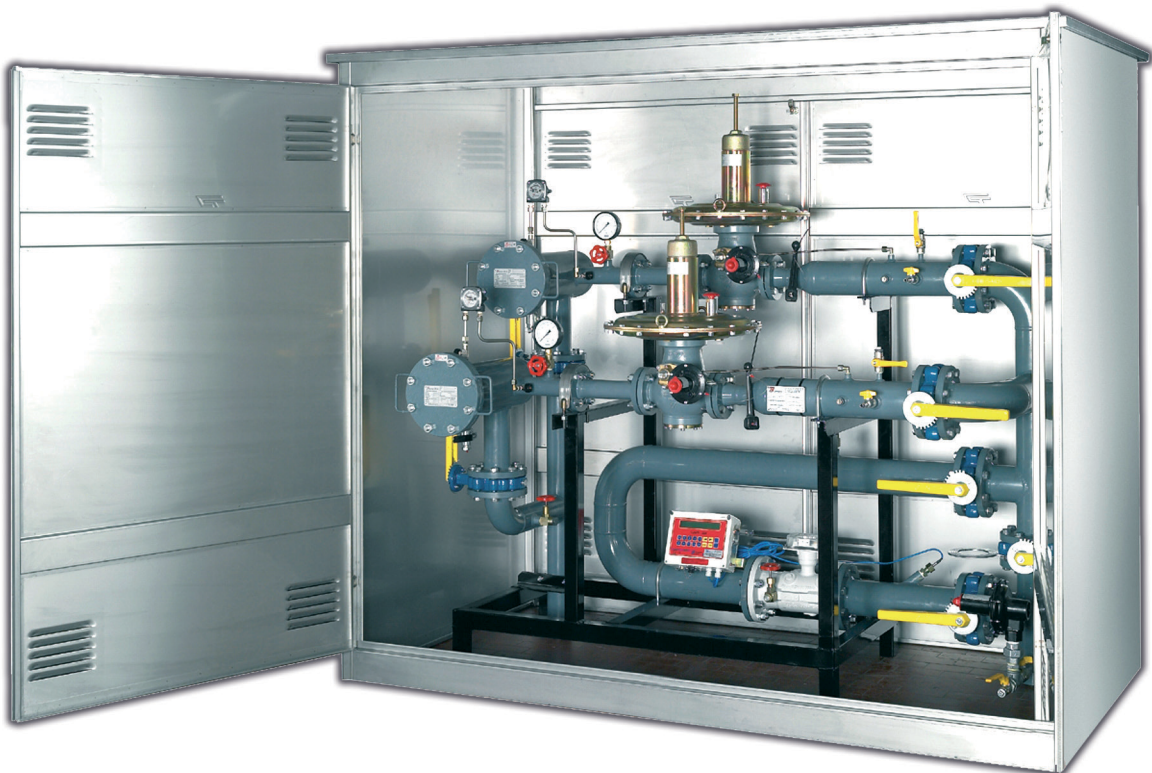

Configurations

Widened Outlet Flange

MN Series



MN Regulator



MBN Regulator + Slam-shut

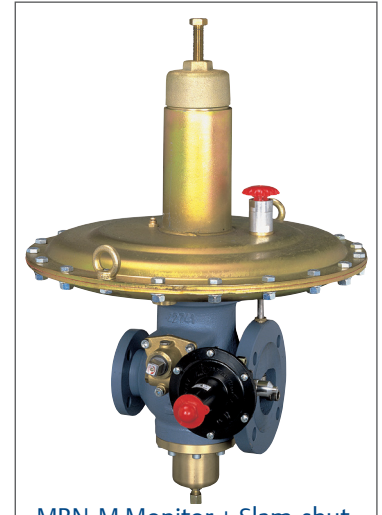

MBN-M Monitor + Slam-shut

Configurations	ID-ABBREVIATIONS			
	Widened Outlet Flange PN 16 – ANSI 150			
	Standard	AP	APA	PST
Regulator	MN	MN-AP	MN-APA	MN-PST
Regulator + Slam-shut	MBN	MBN-AP	MBN-APA	MBN-PST
Monitor + Slam-shut	MBN-M	MBN-M-AP	MBN-M-APA	MBN-PST

SR version with built-in silencer available on request.

Same Size Inlet/Outlet Flanges

MF Series



MF Regulator



MBF Regulator + Slam-shut



MBF-M Monitor + Slam-shut

Configurations	ID-ABBREVIATIONS			
	Same Size Inlet/Outlet Flanges PN 16 – ANSI 150			
	Standard	AP	APA	PST
Regulator	MF	MF-AP	MF-APA	MF-PST
Regulator + Slam-shut	MBF	MBF-AP	MBF-APA	MBF-PST
Monitor + Slam-shut	MBF-M	MBF-M-AP	MBF-M-APA	MBF-PST

SR version with built-in silencer available on request.

M Regulators

Operation

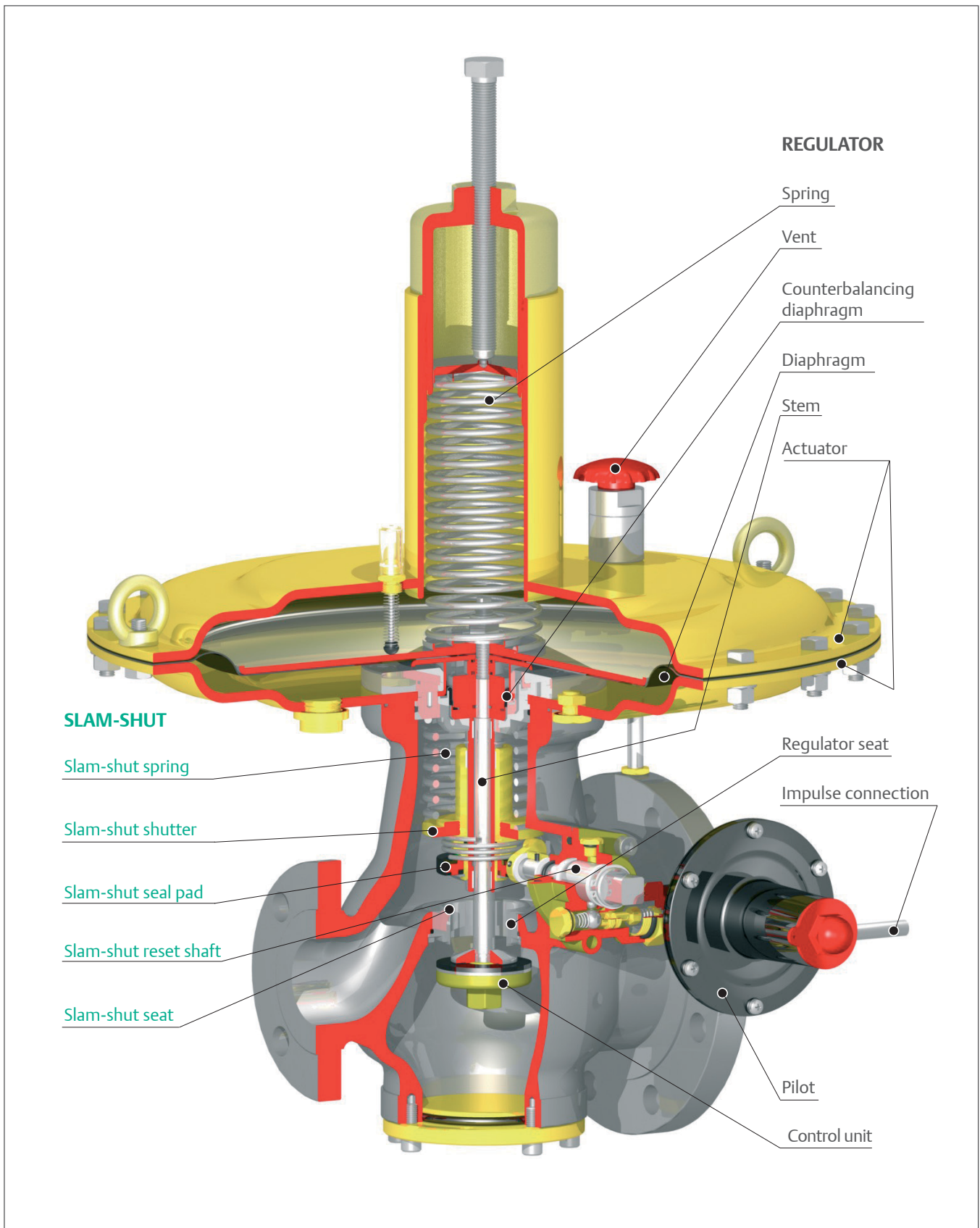

Operation

HOW THE REGULATOR WORKS

The range of position of control member depend from actuator assembly (spring-stem-diaphragm) movements.

The Diaphragm divides the Regulator control head into two chambers.

The lower chambers is connected to regulated pressure P_d , and the other, where the spring regulator is located, is connected to atmospheric pressure.

When the contrasting actions of the spring and outlet pressure coincide, the mobile diaphragm-stem-valve assembly remains motionless, and outlet pressure matches spring set point.

An increase in capacity demand will cause a decrease in outlet pressure. This means that the spring's action will prevail over outlet pressure's action, and the valve will open until set point pressure is again reached at outlet.

The opposite occurs whenever outlet pressure increases.

Precision perfect balancing of control member is assured under all operating conditions by the inlet pressure which operates in the counterbalancing chamber.

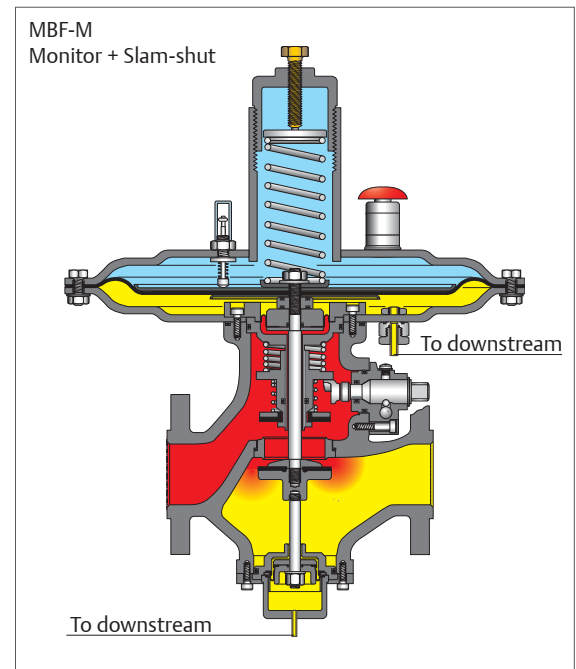

HOW THE MONITOR WORKS

The Monitor or emergency regulator is used as a safety device in gas pressure reduction systems. The purpose of this device is to protect the system against possible overpressure, while keeping the reduction line in service.

The monitor controls downstream pressure at the same point as the main regulator and is set a little higher than the latter. Under normal duty, the monitor is fully open as it detects a pressure value lower than its set value.

If, due to any regulator fault, downstream pressure increases, when it exceeds the tolerated level, the monitor comes into operation and adjusts pressure to its own set value.

HOW THE SLAM-SHUT DEVICE WORKS

The slam-shut device has a shutter and its own seat, and is provided with functions independent of the regulator/monitor.

To keep the shutter open, slam-shut device OS/66 is used is designed to operate on maximum and minimum pressure, on maximum only, on minimum only.

When the system's downstream pressure is at normal operating value, the actuator-pilot remains set and prevents the slam-shut reset shaft from turning by keeping the slam-shut shutter open.

When downstream pressure varies beyond its set limits, the actuator-pilot releases the reset shaft and the shutter is closed by the thrust of the spring.

The shutter can be opened by hand only, by rotating the slam-shut reset shaft anti-clockwise.

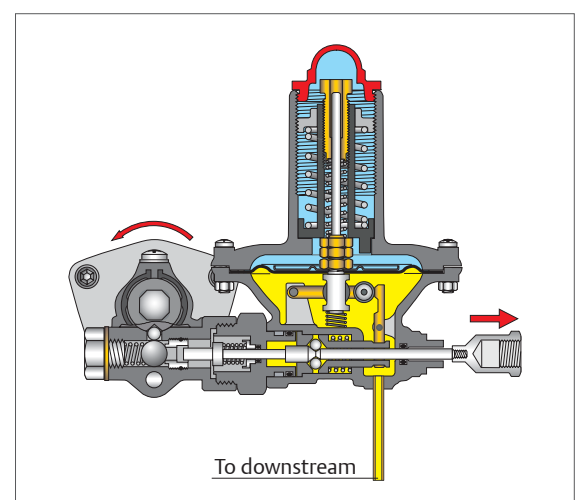

M Regulators

Features

Technical Features

Allowable pressure:

Body	PS	: up to 20 bar
Actuator	PS	: 4 bar
Highest operating pressure	P_{max}	: 3 bar

Permissible inlet pressure:

Standard version DN 25 - 50	$P_{u,max}$: 10 bar
Standard version DN 65 - 80	$P_{u,max}$: 6 bar
Standard version DN 100	$P_{u,max}$: 5 bar
PST version	$P_{u,max}$: 19.6 bar*
AP version	$P_{u,max}$: 19.6 bar*
APA version	$P_{u,max}$: 19.6 bar*

Set range:

Standard version	W_d	: 10 to 500 mbar**
PST version	W_d	: 0.2 to 0.5 bar
AP version	W_d	: 0.5 to 1 bar
APA version	W_d	: 1 to 3 bar

* At average ambient temperature.

** For DN 80 and 100 the operating outlet set pressure range 0.01 to 0.08 bar is allowable with M...- BP version.

Functional Features

Accuracy class	AC	: up to $\pm 5\%$
Lock-up pressure class	SG	: up to + 10%
Class of lock-up pressure zone	SZ	: up to 10%

Built-in Slam-Shut Valve Independent pneumatic control

Accuracy class	AG	: $\pm 5\%$
Response time	t_a	: ≤ 1 s

Flanged connections

MN Series widened outlet flange: 25x65, 40x80, 50x100, 65x100, 80x150, 100x200
MF Series same size inlet/outlet flanges: 25, 40, 50, 80, 100

Flange rating

PN 16 UNI/DIN • ANSI 150

Temperature

Standard version: Working -10 °C +60 °C
Low temperature version: Available on request

Materials

Flanges and covers:	Steel
Diaphragms:	Fabric NBR+PVC/Nitrile rubber
Pads:	NBR Nitrile rubber

Sizing

Selection should be based on maximum capacity demanded by working conditions.

In the DN 25-65 MN series regulator the impulse connection is incorporated in the outlet flange. Maximum capacity in these models is limited by speed of gas flow.

Capacity in these cases can be calculated as a function of actual outlet pressure as shown in the following chart. The outlet pressure capacity chart can be used for quickly checking that capacity demand falls within regulator operating range.

If capacity demand is greater than regulator operating range, an expansion cone will have to be fitted and the control connection shifted beyond the cone.

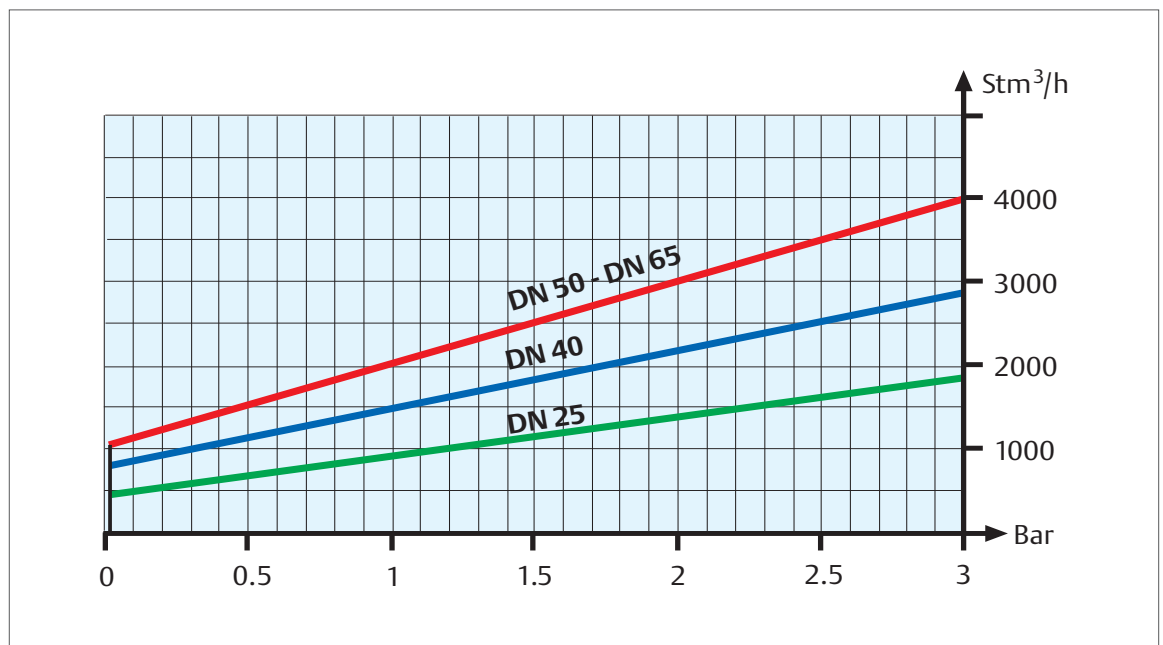

Flow Tables

Following flow tables (referred to Natural Gas) are advised for an optimal use of the M/series regulators.

For other gases with different densities, the flow rate must be multiplied by the correction factor:

$$F = \sqrt{\frac{0.6}{d}}$$

Gas	Relative Density d	Factor F
Air	1	0.78
Butane	2.01	0.55
Propane	1.53	0.63
Nitrogen	0.97	0.79

M Regulators

MN/ Series Flow Tables Stm³/h

P _{in} / P _{out} (P _{bar})	0,05	0,1	0,15	0,2	0,3	0,4	0,5	0,6	0,7	0,8	1	1,25	1,5	2	3	4	5	6	7	8	10	11-19
0,02	60	110	140	170	220	250	280	310	330	360	400	450	500	600	750	900	950	950	950	950	950	-
0,03	50	100	130	170	220	250	280	310	330	360	400	450	500	600	750	900	950	950	950	950	950	-
0,05	-	90	125	160	210	240	270	300	330	360	400	450	500	600	750	900	950	950	950	950	950	-
0,08	-	60	110	150	200	380	260	300	320	350	400	450	500	600	750	900	1000	950	1000	1000	1000	-
0,1	-	-	90	140	190	230	250	300	320	350	400	450	500	600	750	1000	1050	1050	1050	1050	1050	-
0,2	-	-	-	-	140	200	240	280	310	340	390	450	500	600	750	1000	1050	1100	1100	1100	1100	-
0,25	-	-	-	-	-	160	220	260	300	330	380	440	500	600	750	1000	1050	1150	1200	1200	1200	1200
0,3	-	-	-	-	-	150	210	250	290	320	380	440	500	600	750	1000	1050	1150	1300	1300	1300	1300
0,4	-	-	-	-	-	-	160	220	260	300	360	430	500	600	750	1000	1050	1150	1300	1300	1300	1300
0,5	-	-	-	-	-	-	-	160	220	270	350	420	490	600	750	1000	1050	1150	1400	1400	1400	1400



 *PST version*

AP Version

P _{in} / P _{out} (P _{bar})	0,5	0,6	0,7	0,8	1	1,25	1,5	2	3	4	5	6	7	8	10	11-19
0,4	160	220	260	300	360	430	500	600	750	1000	1050	1150	1300	1300	1300	1300
0,5	-	160	220	270	350	420	490	600	750	1000	1050	1150	1400	1400	1400	1400
0,6	-	-	170	230	320	410	480	600	750	1000	1050	1150	1400	1500	1500	1500
0,7	-	-	-	170	290	390	460	590	750	1000	1050	1150	1400	1600	1600	1600
0,8	-	-	-	-	250	360	450	580	750	1000	1050	1150	1400	1600	1700	1700
1	-	-	-	-	-	290	400	560	750	1000	1050	1150	1400	1600	2000	1900

APA Version

P _{in} / P _{out} (P _{bar})	1,25	1,5	2	3	4	5	6	7	8	10	11-19	
1	290	400	560	750	1000	1050	1150	1400	1600	2000	1900	
1,5	-	-	450	700	1000	1050	1150	1400	1600	2000	2200	
2	-	-	-	700	1000	1050	1150	1400	1600	2000	2200	
2,5	-	-	-	-	550	910	1050	1150	1400	1600	2000	2200
3	-	-	-	-	-	810	1000	1100	1400	1600	2000	2200

P _{in} / P _{out} (P _{bar})	0,05	0,1	0,15	0,2	0,3	0,4	0,5	0,6	0,7	0,8	1	1,25	1,5	2	3	4	5	6	7	8	10	11-19
0,02	150	230	290	340	410	470	520	580	610	640	710	800	900	1050	1400	1700	1800	1800	1800	1800	1800	-
0,03	122	220	280	330	400	460	510	570	600	640	710	800	900	1050	1400	1700	1800	1800	1800	1800	1800	-
0,05	-	150	260	320	390	450	500	560	590	640	710	800	900	1050	1400	1700	1800	1800	1800	1800	1800	-
0,08	-	120	230	290	380	440	490	550	590	630	710	800	900	1050	1400	1700	1800	1800	1800	1800	1800	-
0,1	-	-	190	270	370	430	480	540	580	620	710	800	900	1050	1400	1700	1850	1850	1850	1850	1850	-
0,2	-	-	-	-	280	390	470	530	570	600	700	790	850	1050	1400	1700	2000	2000	2000	2000	2000	-
0,25	-	-	-	-	210	350	440	510	560	620	700	790	850	1050	1400	1700	2100	2100	2100	2100	2100	2100
0,3	-	-	-	-	-	290	410	490	540	580	690	780	850	1000	1400	1700	2100	2200	2200	2200	2200	2200
0,4	-	-	-	-	-	-	310	420	500	570	670	770	850	1000	1400	1700	2100	2300	2300	2300	2300	2300
0,5	-	-	-	-	-	-	-	320	440	520	640	750	850	1000	1400	1700	2100	2400	2500	2500	2500	2500



 *PST version*

AP Version

P _{in} / P _{out} (P _{bar})	0,5	0,6	0,7	0,8	1	1,25	1,5	2	3	4	5	6	7	8	10	11-19
0,4	310	420	500	570	670	770	850	1000	1400	1700	2100	2300	2300	2300	2300	2300
0,5	-	320	440	520	640	750	850	1000	1400	1700	2100	2400	2500	2500	2500	2500
0,6	-	-	330	450	600	740	850	1000	1400	1700	2100	2400	2600	2600	2600	2600
0,7	-	-	-	340	550	710	830	1000	1200	1700	2100	2400	2800	2800	2800	2800
0,8	-	-	-	-	460	680	790	980	1300	1700	2100	2400	2800	2900	2900	2900
1	-	-	-	-	-	550	730	950	1350	1700	2100	2400	2800	3200	3100	3100

APA Version

P _{in} / P _{out} (P _{bar})	1,25	1,5	2	3	4	5	6	7	8	10	11-19	
1	550	730	950	1350	1700	2100	2400	2800	3200	3100	3100	
1,5	-	-	840	1250	1650	2100	2400	2800	3200	3900	3600	
2	-	-	-	1150	1400	2050	2200	2800	3200	3900	4200	
2,5	-	-	-	-	950	1100	1800	2400	2800	3200	3900	4200
3	-	-	-	-	-	1050	1800	2400	2800	3200	3900	4200

MN/ Series Flow Tables Stm³/h

Pubar Pdbar	0,05	0,1	0,15	0,2	0,3	0,4	0,5	0,6	0,7	0,8	1	1,25	1,5	2	3	4	5	6	7	8	10	11-19
0,02	200	330	390	480	580	660	730	800	850	900	1000	1100	1200	1450	1450	2450	2600	2600	2600	2600	2600	-
0,03	160	320	380	470	580	660	730	800	850	900	1000	1100	1200	1450	1450	2450	2600	2600	2600	2600	2600	-
0,05	-	270	350	450	570	650	730	790	850	900	1000	1100	1200	1450	1450	2450	2650	2650	2650	2650	2650	-
0,08	-	160	300	420	540	640	720	790	840	900	1000	1100	1200	1450	1450	2450	2700	2700	2700	2700	2700	-
0,1	-	-	170	390	520	630	710	780	840	900	1000	1100	1200	1450	1450	2450	2750	2750	2750	2750	2750	-
0,2	-	-	-	-	400	550	660	750	820	880	1000	1100	1200	1450	1450	2450	2850	3000	3000	3000	3000	-
0,25	-	-	-	-	290	490	620	720	800	870	1000	1100	1200	1450	1450	2450	2850	3100	3100	3100	3100	3100
0,3	-	-	-	-	-	420	580	690	780	860	990	1100	1200	1450	1450	2450	2850	3400	3400	3400	3400	3400
0,4	-	-	-	-	-	-	430	600	720	820	970	1050	1200	1450	1900	2450	2850	3400	3700	3700	3700	3700
0,5	-	-	-	-	-	-	-	450	630	750	930	1050	1200	1450	1900	2450	2850	3400	3900	4000	4000	4000

PST version



AP Version

Pubar Pdbar	0,5	0,6	0,7	0,8	1	1,25	1,5	2	3	4	5	6	7	8	10	11-19
0,4	430	600	720	820	970	1050	1200	1450	1900	2450	2850	3400	3700	3700	3700	3700
0,5	-	450	630	750	930	1050	1200	1450	1900	2450	2850	3400	3900	4000	4000	4000
0,6	-	-	460	650	880	1000	1200	1450	1900	2450	2850	3400	3900	4200	4200	4200
0,7	-	-	-	480	800	1000	1200	1450	1900	2450	2850	3400	3900	4400	4600	4600
0,8	-	-	-	-	680	990	1150	1450	1900	2450	2850	3400	3900	4400	4900	4900
1	-	-	-	-	-	800	1050	1400	1850	2450	2850	3400	3900	4400	5400	5300

APA Version

Pubar Pdbar	1,25	1,5	2	3	4	5	6	7	8	10	11-19
1	800	1050	1400	1850	2450	2850	3400	3900	4400	5400	5300
1,5	-	-	1200	1850	2400	2850	3400	3900	4400	5400	5900
2	-	-	-	1750	2400	2850	3400	3900	4400	5400	5900
2,5	-	-	-	-	2300	2850	3400	3900	4400	5400	5900
3	-	-	-	-	-	2100	2800	3300	3900	4400	5400

Pubar Pdbar	0,05	0,1	0,15	0,2	0,3	0,4	0,5	0,6	0,7	0,8	1	1,25	1,5	2	3	4	5	6	7	8	10	11-19
0,02	300	480	620	720	890	1000	1150	1250	1350	1450	1600	1800	2000	2400	3200	4000	4400	-	-	-	-	-
0,03	250	460	600	700	880	1000	1150	1250	1350	1450	1600	1800	2000	2400	3200	4000	4400	-	-	-	-	-
0,05	-	400	550	670	850	1000	1100	1250	1350	1450	1600	1800	2000	2400	3200	4000	4500	-	-	-	-	-
0,08	-	250	470	610	820	980	1100	1250	1350	1450	1600	1800	2000	2400	3200	4000	4650	-	-	-	-	-
0,1	-	-	400	560	790	960	1100	1250	1350	1450	1600	1800	2000	2400	3200	4000	4750	-	-	-	-	-
0,2	-	-	-	-	590	820	1000	1200	1300	1400	1600	1800	2000	2400	3200	4000	4900	-	-	-	-	-
0,25	-	-	-	-	470	800	1000	1150	1300	1400	1600	1800	2000	2400	3200	4000	4900	5400	5400	5400	5400	5400
0,3	-	-	-	-	-	620	860	1100	1250	1400	1600	1800	2000	2400	3200	4000	4900	5600	5600	5600	5600	5600
0,4	-	-	-	-	-	-	640	980	1150	1300	1550	1800	2000	2400	3200	4000	4900	5700	6000	6000	6000	6000
0,5	-	-	-	-	-	-	-	730	1000	1200	1500	1800	2000	2400	3200	4000	4900	5700	6450	6500	6500	6500

PST version



AP Version

Pubar Pdbar	0,5	0,6	0,7	0,8	1	1,25	1,5	2	3	4	5	6	7	8	10	11-19
0,4	640	980	1150	1300	1550	1800	2000	2400	3200	4000	4900	5700	6000	6000	6000	6000
0,5	-	730	1000	1200	1500	1800	2000	2400	3200	4000	4900	5700	6450	6500	6500	6500
0,6	-	-	760	1050	1400	1750	2000	2400	3200	4000	4900	5700	6450	6900	6900	6900
0,7	-	-	-	780	1300	1700	2000	2400	3200	4000	4900	5700	6450	7300	7400	7400
0,8	-	-	-	-	1100	1600	1950	2400	3200	4000	4900	5700	6450	7300	7800	7800
1	-	-	-	-	-	1300	1750	2350	3200	4000	4900	5700	6450	7300	8700	8700

APA Version

Pubar Pdbar	1,25	1,5	2	3	4	5	6	7	8	10	11-19
1	1300	1750	2350	3200	4000	4900	5700	6450	7300	8700	8700
1,5	-	-	2000	3100	4000	4900	5700	6450	7300	8900	9600
2	-	-	-	3000	4000	4900	5700	6450	7300	8900	9700
2,5	-	-	-	2400	3900	4850	5700	6450	7300	8900	9700
3	-	-	-	-	3500	4800	5700	6450	7300	8900	9700

M Regulators

MN/ Series Flow Tables Stm³/h

P _{in} / P _{out} (P _{in} / P _{out})	0,05	0,1	0,15	0,2	0,3	0,4	0,5	0,6	0,7	0,8	1	1,25	1,5	2	3	4	5	6	7	8	10	11-19
0,02	470	750	950	1100	1350	1500	1700	1800	1950	2050	2300	2600	2900	3400	4600	5700	6900	-	-	-	-	-
0,03	390	720	900	1050	1300	1500	1700	1800	1950	2050	2300	2600	2900	3400	4600	5700	6900	-	-	-	-	-
0,05	-	620	850	1000	1300	1500	1650	1800	1950	2050	2300	2600	2900	3400	4600	5700	6900	-	-	-	-	-
0,08	-	400	740	950	1250	1450	1650	1800	1950	2050	2300	2600	2900	3400	4600	5700	6900	-	-	-	-	-
0,1	-	-	630	880	1200	1450	1600	1800	1900	2050	2300	2600	2900	3400	4600	5700	6900	-	-	-	-	-
0,2	-	-	-	650	920	1250	1500	1700	1900	2050	2300	2600	2900	3400	4600	5700	6900	-	-	-	-	-
0,25	-	-	-	-	680	1150	1400	1650	1850	2000	2300	2600	2900	3400	4600	5700	6900	8100	9200	10300	12000	12000
0,3	-	-	-	-	-	950	1300	1600	1800	1950	2250	2600	2850	3400	4600	5700	6900	8100	9200	10300	12600	12600
0,4	-	-	-	-	-	-	1000	1350	1650	1850	2200	2550	2850	3400	4600	5700	6900	8100	9200	10300	12600	13500
0,5	-	-	-	-	-	-	-	1000	1400	1700	2150	2550	2850	3400	4600	5700	6900	8100	9200	10300	12600	13800



PST version

AP Version

P _{in} / P _{out} (P _{in} / P _{out})	0,5	0,6	0,7	0,8	1	1,25	1,5	2	3	4	5	6	7	8	10	11-19
0,4	1000	1350	1650	1850	2200	2550	2850	3400	4600	5700	6900	8100	9200	10300	12600	13500
0,5	-	1000	1400	1700	2150	2550	2850	3400	4600	5700	6900	8100	9200	10300	12600	13800
0,6	-	-	1050	1450	2000	2500	2850	3400	4600	5700	6900	8100	9200	10300	12600	13800
0,7	-	-	-	1100	1850	2400	2800	3400	4600	5700	6900	8100	9200	10300	12600	13800
0,8	-	-	-	-	1500	2250	2750	3400	4600	5700	6900	8100	9200	10300	12600	13800
1	-	-	-	-	-	1850	2500	3400	4600	5700	6900	8100	9200	10300	12600	13800

APA Version

P _{in} / P _{out} (P _{in} / P _{out})	1,25	1,5	2	3	4	5	6	7	8	10	11-19	
1	1850	2500	3400	4600	5700	6900	8100	9200	10300	12600	13800	
1,5	-	-	2850	4550	5700	6900	8100	9200	10300	12600	13800	
2	-	-	-	4300	5700	6900	8100	9200	10300	12600	13800	
2,5	-	-	-	-	3400	5500	6900	8000	9200	10300	12600	13800
3	-	-	-	-	-	5000	6800	8000	9100	10300	12600	13800

P _{in} / P _{out} (P _{in} / P _{out})	0,05	0,1	0,15	0,2	0,3	0,4	0,5	0,6	0,7	0,8	1	1,25	1,5	2	3	4	5	6	7	8	10	11-19
0,02	730	1150	1450	1700	2050	2350	2600	2800	3000	3200	3550	4000	4400	5300	7100	8800	10500	-	-	-	-	-
0,03	600	1100	1400	1650	2050	2350	2600	2800	3000	3200	3550	4000	4400	5300	7100	8800	10500	-	-	-	-	-
0,05	-	950	1300	1600	2000	2300	2550	2800	3000	3200	3550	4000	4400	5300	7100	8800	10500	-	-	-	-	-
0,08	-	620	1100	1450	1900	2250	2550	2750	3000	3200	3550	4000	4400	5300	7100	8800	10500	-	-	-	-	-
0,1	-	-	950	1350	1850	2200	2500	2750	3000	3200	3550	4000	4400	5300	7110	8800	10500	-	-	-	-	-
0,2	-	-	-	-	1400	1950	2300	2650	2900	3100	3550	4000	4400	5300	7100	8800	10500	-	-	-	-	-
0,25	-	-	-	-	1000	1750	2200	2550	2850	3100	3500	4000	4400	5300	7100	8800	10500	12400	14000	15700	19200	21000
0,3	-	-	-	-	-	1450	2000	2450	2750	3000	3500	4000	4400	5300	7100	8800	10500	12400	14000	15700	19200	21000
0,4	-	-	-	-	-	-	1500	2100	2550	2850	3450	4000	4400	5300	7100	8800	10500	12400	14000	15700	19200	21000
0,5	-	-	-	-	-	-	-	1600	2200	2600	3300	3900	4400	5300	7100	8800	10500	12400	14000	15700	19200	21000



PST version

AP Version

P _{in} / P _{out} (P _{in} / P _{out})	0,5	0,6	0,7	0,8	1	1,25	1,5	2	3	4	5	6	7	8	10	11-19
0,4	1500	2100	2550	2850	3450	4000	4400	5300	7100	8800	10500	12400	14000	15700	19200	21000
0,5	-	1600	2200	2600	3300	3900	4400	5300	7100	8800	10500	12400	14000	15700	19200	21000
0,6	-	-	1650	2250	3100	3850	4400	5300	7100	8800	10500	12400	14000	15700	19200	21000
0,7	-	-	-	1700	2850	3700	4350	5300	7100	8800	10500	12400	14000	15700	19200	21000
0,8	-	-	-	-	2400	3500	4250	5300	7100	8800	10500	12400	14000	15700	19200	21000
1	-	-	-	-	-	2850	3900	5200	7100	8800	10500	12400	14000	15700	19200	21000

APA Version

P _{in} / P _{out} (P _{in} / P _{out})	1,25	1,5	2	3	4	5	6	7	8	10	11-19	
1	2850	3900	5200	7100	8800	10500	12400	14000	15700	19200	21000	
1,5	-	-	4400	7000	8750	10500	12400	14000	15700	19200	21000	
2	-	-	-	6600	8700	10500	12400	14000	15700	19200	21000	
2,5	-	-	-	-	5300	8500	10500	12400	14000	15700	19200	21000
3	-	-	-	-	-	7700	10500	12400	14000	15700	19200	21000

MF/ Series Flow Tables Stm³/h

P _{in} / P _{out} (P _{bar})	0,05	0,1	0,15	0,2	0,3	0,4	0,5	0,6	0,7	0,8	1	1,25	1,5	2	3	4	5	6	7	8	10	11-19
0,02	60	110	140	170	220	250	280	280	280	280	280	280	280	280	280	280	280	280	280	280	280	-
0,03	50	100	130	170	220	250	280	280	280	280	280	280	280	280	280	280	280	280	280	280	280	-
0,05	-	90	125	160	210	240	270	290	290	290	290	290	290	290	290	290	290	290	290	290	290	-
0,08	-	60	110	150	200	380	260	300	300	300	300	300	300	300	300	300	300	300	300	300	300	-
0,1	-	-	90	140	190	230	250	300	300	300	300	300	300	300	300	300	300	300	300	300	300	-
0,2	-	-	-	-	140	200	240	280	310	320	320	320	320	320	320	320	320	320	320	320	320	-
0,25	-	-	-	-	-	160	220	260	300	330	340	340	340	340	340	340	340	340	340	340	340	340
0,3	-	-	-	-	-	150	210	250	290	320	350	350	350	350	350	350	350	350	350	350	350	350
0,4	-	-	-	-	-	-	160	220	260	300	360	360	360	360	360	360	360	360	360	360	360	360
0,5	-	-	-	-	-	-	-	160	220	270	350	400	400	400	400	400	400	400	400	400	400	400



PST version

AP Version

P _{in} / P _{out} (P _{bar})	0,5	0,6	0,7	0,8	1	1,25	1,5	2	3	4	5	6	7	8	10	11-19
0,4	160	220	260	300	360	360	360	360	360	360	360	360	360	360	360	360
0,5	-	160	220	270	350	400	400	400	400	400	400	400	400	400	400	400
0,6	-	-	170	230	320	410	440	440	440	440	440	440	440	440	440	440
0,7	-	-	-	170	290	390	430	430	430	430	430	430	430	430	430	430
0,8	-	-	-	-	250	360	450	500	500	500	500	500	500	500	500	500
1	-	-	-	-	-	290	400	560	560	560	560	560	560	560	560	560

APA Version

P _{in} / P _{out} (P _{bar})	1,25	1,5	2	3	4	5	6	7	8	10	11-19
1	200	380	540	640	640	640	640	640	640	640	640
1,5	-	-	450	680	680	680	680	680	680	680	680
2	-	-	-	700	800	800	800	800	800	800	800
2,5	-	-	-	-	550	910	950	950	950	950	950
3	-	-	-	-	-	810	1000	1000	1000	1000	1000

P _{in} / P _{out} (P _{bar})	0,05	0,1	0,15	0,2	0,3	0,4	0,5	0,6	0,7	0,8	1	1,25	1,5	2	3	4	5	6	7	8	10	11-19
0,02	150	230	290	340	410	470	520	580	610	640	710	710	710	710	710	710	710	710	710	710	710	-
0,03	122	220	280	330	400	460	510	570	600	640	710	710	710	710	710	710	710	710	710	710	710	-
0,05	-	150	260	320	390	450	500	560	590	640	710	720	720	720	720	720	720	720	720	720	720	-
0,08	-	120	230	290	380	440	490	550	590	630	710	750	750	750	750	750	750	750	750	750	750	-
0,1	-	-	190	270	370	430	480	540	580	620	710	800	800	800	800	800	800	800	800	800	800	-
0,2	-	-	-	-	280	390	470	530	570	600	700	790	850	850	850	850	850	850	850	850	850	-
0,25	-	-	-	-	210	350	440	510	560	620	700	790	850	870	870	870	870	870	870	870	870	870
0,3	-	-	-	-	-	290	410	490	540	580	690	780	850	1000	1000	1000	1000	1000	1000	1000	1000	1000
0,4	-	-	-	-	-	-	310	420	500	570	670	770	850	1000	1000	1000	1000	1000	1000	1000	1000	1000
0,5	-	-	-	-	-	-	-	320	440	520	640	750	850	1000	1000	1000	1000	1000	1000	1000	1000	1000



PST version

AP Version

P _{in} / P _{out} (P _{bar})	0,5	0,6	0,7	0,8	1	1,25	1,5	2	3	4	5	6	7	8	10	11-19
0,4	310	420	500	570	670	770	850	1000	1000	1000	1000	1000	1000	1000	1000	1000
0,5	-	320	440	520	640	750	850	1000	1000	1000	1000	1000	1000	1000	1000	1000
0,6	-	-	330	450	600	740	850	1000	1100	1100	1100	1100	1100	1100	1100	1100
0,7	-	-	-	340	550	710	830	1000	1200	1200	1200	1200	1200	1200	1200	1200
0,8	-	-	-	-	460	680	790	980	1300	1300	1300	1300	1300	1300	1300	1300
1	-	-	-	-	-	550	730	950	1350	1350	1350	1350	1350	1350	1350	1350

APA Version

P _{in} / P _{out} (P _{bar})	1,25	1,5	2	3	4	5	6	7	8	10	11-19
1	550	730	950	1350	1350	1350	1350	1350	1350	1350	1350
1,5	-	-	840	1250	1650	2100	1800	1800	1800	1800	1800
2	-	-	-	1150	1400	2050	2200	2200	2200	2200	2200
2,5	-	-	-	-	950	1100	1800	2400	2400	2400	2400
3	-	-	-	-	-	1050	1800	2400	2800	2800	2800

M Regulators

MF/ Series Flow Tables Stm³/h

P _{in} / P _{out} (bar)	0,05	0,1	0,15	0,2	0,3	0,4	0,5	0,6	0,7	0,8	1	1,25	1,5	2	3	4	5	6	7	8	10	11-19
0,02	200	330	390	480	580	660	730	800	850	900	1000	1100	1100	1100	1100	1100	1100	1100	1100	1100	1100	-
0,03	160	320	380	470	580	660	730	800	850	900	1000	1100	1100	1100	1100	1100	1100	1100	1100	1100	1100	-
0,05	-	270	350	450	570	650	730	790	850	900	1000	1100	1100	1100	1100	1100	1100	1100	1100	1100	1100	-
0,08	-	160	300	420	540	640	720	790	840	900	1000	1100	1150	1150	1150	1150	1150	1150	1150	1150	1150	-
0,1	-	-	170	390	520	630	710	780	840	900	1000	1100	1200	1200	1200	1200	1200	1200	1200	1200	1200	-
0,2	-	-	-	-	400	550	660	750	820	880	1000	1100	1200	1300	1300	1300	1300	1300	1300	1300	1300	-
0,25	-	-	-	-	290	490	620	720	800	870	1000	1100	1200	1350	1350	1350	1350	1350	1350	1350	1350	1350
0,3	-	-	-	-	-	420	580	690	780	860	990	1100	1200	1400	1400	1400	1400	1400	1400	1400	1400	1400
0,4	-	-	-	-	-	-	430	600	720	820	970	1050	1200	1450	1500	1500	1500	1500	1500	1500	1500	1500
0,5	-	-	-	-	-	-	-	450	630	750	930	1050	1200	1450	1600	1600	1600	1600	1600	1600	1600	1600



PST version

AP Version

P _{in} / P _{out} (bar)	0,5	0,6	0,7	0,8	1	1,25	1,5	2	3	4	5	6	7	8	10	11-19
0,4	430	600	720	820	970	1050	1200	1450	1500	1500	1500	1500	1500	1500	1500	1500
0,5	-	450	630	750	930	1050	1200	1450	1600	1600	1600	1600	1600	1600	1600	1600
0,6	-	-	460	650	880	1000	1200	1450	1700	1700	1700	1700	1700	1700	1700	1700
0,7	-	-	-	480	800	1000	1200	1450	1800	1800	1800	1800	1800	1800	1800	1800
0,8	-	-	-	-	680	990	1150	1450	1900	1900	1900	1900	1900	1900	1900	1900
1	-	-	-	-	-	800	1050	1400	1850	2150	2150	2150	2150	2150	2150	2150

APA Version

P _{in} / P _{out} (bar)	1,25	1,5	2	3	4	5	6	7	8	10	11-19
1	800	1050	1400	1850	2150	2150	2150	2150	2150	2150	2150
1,5	-	-	1200	1850	2400	2700	2700	2700	2700	2700	2700
2	-	-	-	1750	2400	2850	3200	3200	3200	3200	3200
2,5	-	-	-	-	2300	2850	3400	3800	3800	3800	3800
3	-	-	-	-	2100	2800	3300	3900	4300	4300	4300

P _{in} / P _{out} (bar)	0,05	0,1	0,15	0,2	0,3	0,4	0,5	0,6	0,7	0,8	1	1,25	1,5	2	3	4	5	6	7	8	10	11-19
0,02	470	750	950	1100	1350	1500	1700	1800	1950	2050	2300	2600	2800	2800	2800	2800	2800	-	-	-	-	-
0,03	390	720	900	1050	1300	1500	1700	1800	1950	2050	2300	2600	2800	2800	2800	2800	2800	-	-	-	-	-
0,05	-	620	850	1000	1300	1500	1650	1800	1950	2050	2300	2600	2900	2900	2900	2900	2900	-	-	-	-	-
0,08	-	400	740	950	1250	1450	1650	1800	1950	2050	2300	2600	2900	3000	3000	3000	3000	-	-	-	-	-
0,1	-	-	630	880	1200	1450	1600	1800	1900	2050	2300	2600	2900	3050	3050	3050	3050	-	-	-	-	-
0,2	-	-	-	650	920	1250	1500	1700	1900	2050	2300	2600	2900	3300	3300	3300	3300	-	-	-	-	-
0,25	-	-	-	-	680	1150	1400	1650	1850	2000	2300	2600	2900	3400	3500	3500	3500	3500	3500	3500	3500	3500
0,3	-	-	-	-	-	950	1300	1600	1800	1950	2250	2600	2850	3400	3600	3600	3600	3600	3600	3600	3600	3600
0,4	-	-	-	-	-	-	1000	1350	1650	1850	2200	2550	2850	3400	3900	3900	3900	3900	3900	3900	3900	3900
0,5	-	-	-	-	-	-	-	1000	1400	1700	2150	2550	2850	3400	4150	4150	4150	4150	4150	4150	4150	4150



PST version

AP Version

P _{in} / P _{out} (bar)	0,5	0,6	0,7	0,8	1	1,25	1,5	2	3	4	5	6	7	8	10	11-19
0,4	1000	1350	1650	1850	2200	2550	2850	3400	3900	3900	3900	3900	3900	3900	3900	3900
0,5	-	1000	1400	1700	2150	2550	2850	3400	4150	4150	4150	4150	4150	4150	4150	4150
0,6	-	-	1050	1450	2000	2500	2850	3400	4450	4450	4450	4450	4450	4450	4450	4450
0,7	-	-	-	1100	1850	2400	2800	3400	4600	4700	4700	4700	4700	4700	4700	4700
0,8	-	-	-	-	1500	2250	2750	3400	4600	5000	5000	5000	5000	5000	5000	5000
1	-	-	-	-	-	1850	2500	3400	4600	5500	5500	5500	5500	5500	5500	5500

APA Version

P _{in} / P _{out} (bar)	1,25	1,5	2	3	4	5	6	7	8	10	11-19
1	1850	2500	3400	4600	5500	5500	5500	5500	5500	5500	5500
1,5	-	-	2850	4550	5700	6900	6900	6900	6900	6900	6900
2	-	-	-	4300	5700	6900	8100	8300	8300	8300	8300
2,5	-	-	-	3400	5500	6900	8000	9200	9700	9700	9700
3	-	-	-	-	5000	6800	8000	9100	10300	11200	11200

MF/ Series Flow Tables Stm³/h

Pubar \ Pubar	0,05	0,1	0,15	0,2	0,3	0,4	0,5	0,6	0,7	0,8	1	1,25	1,5	2	3	4	5	6	7	8	10	11-19
0,02	730	1150	1450	1700	2050	2350	2600	2800	3000	3200	3550	4000	4400	4400	4400	4400	4400	-	-	-	-	-
0,03	600	1100	1400	1650	2050	2350	2600	2800	3000	3200	3550	4000	4400	4450	4450	4450	4450	-	-	-	-	-
0,05	-	950	1300	1600	2000	2300	2550	2800	3000	3200	3550	4000	4400	4500	4500	4500	4500	-	-	-	-	-
0,08	-	620	1100	1450	1900	2250	2550	2750	3000	3200	3550	4000	4400	4650	4650	4650	4650	-	-	-	-	-
0,1	-	-	950	1350	1850	2200	2500	2750	3000	3200	3550	4000	4400	4800	4800	4800	4800	-	-	-	-	-
0,2	-	-	-	-	1400	1950	2300	2650	2900	3100	3550	4000	4400	5200	5200	5200	5200	-	-	-	-	-
0,25	-	-	-	-	1000	1750	2200	2550	2850	3100	3500	4000	4400	5300	5400	5400	5400	5400	5400	5400	5400	5400
0,3	-	-	-	-	-	1450	2000	2450	2750	3000	3500	4000	4400	5300	5600	5600	5600	5600	5600	5600	5600	5600
0,4	-	-	-	-	-	-	1500	2100	2550	2850	3450	4000	4400	5300	6100	6100	6100	6100	6100	6100	6100	6100
0,5	-	-	-	-	-	-	-	1600	2200	2600	3300	3900	4400	5300	6500	6500	6500	6500	6500	6500	6500	6500

 PST version



AP Version

Pubar \ Pubar	0,5	0,6	0,7	0,8	1	1,25	1,5	2	3	4	5	6	7	8	10	11-19
0,4	1500	2100	2550	2850	3450	4000	4400	5300	6100	6100	6100	6100	6100	6100	6100	6100
0,5	-	1600	2200	2600	3300	3900	4400	5300	6500	6500	6500	6500	6500	6500	6500	6500
0,6	-	-	1650	2250	3100	3850	4400	5300	7000	7000	7000	7000	7000	7000	7000	7000
0,7	-	-	-	1700	2850	3700	4350	5300	7100	7400	7400	7400	7400	7400	7400	7400
0,8	-	-	-	-	2400	3500	4250	5300	7100	7800	7800	7800	7800	7800	7800	7800
1	-	-	-	-	-	2850	3900	5200	7100	8700	8700	8700	8700	8700	8700	8700

APA Version

Pubar \ Pubar	1,25	1,5	2	3	4	5	6	7	8	10	11-19
1	2850	3900	5200	7100	8700	8700	8700	8700	8700	8700	8700
1,5	-	-	4400	7000	8750	10500	10900	10900	10900	10900	10900
2	-	-	-	6600	8700	10500	12400	13000	13000	13000	13000
2,5	-	-	-	5300	8500	10500	12400	14000	15300	15300	15300
3	-	-	-	-	7700	10500	12400	14000	15700	17500	17500

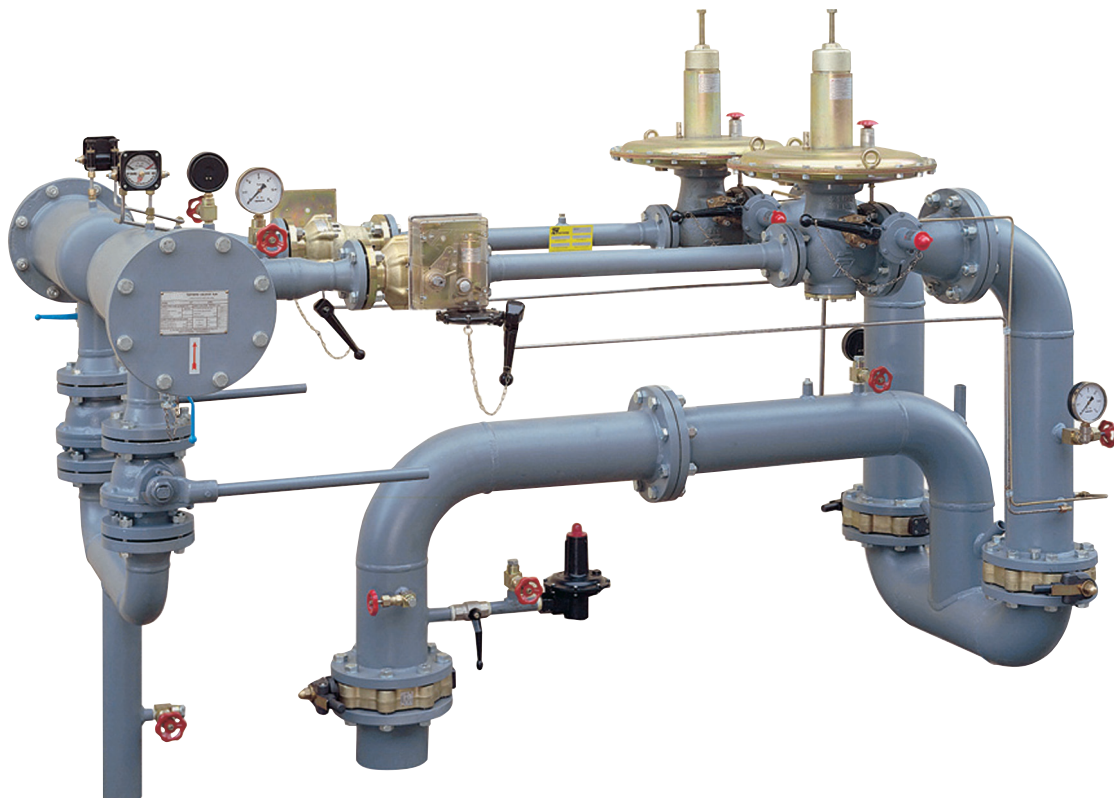

M Regulators

Slam-Shut Device

The OS/66 spring loaded slam-shut devices is used with M series regulators with built-in slam-shut device.

Technical Features

Model	Servomotor Body Resistance (bar)	Overpressure Set Range W_{do} (bar)		Underpressure Set Range W_{du} (bar)	
		Min.	Max.	Min.	Max.
OS/66	6	0.022	0.6	0.007	0.450
OS/66-AP		0.2	5	0.1	2.5

Materials

OS/66, OS/66-AP
 Body: Aluminium
 Cover: Steel
 Diaphragm: NBR Rubber

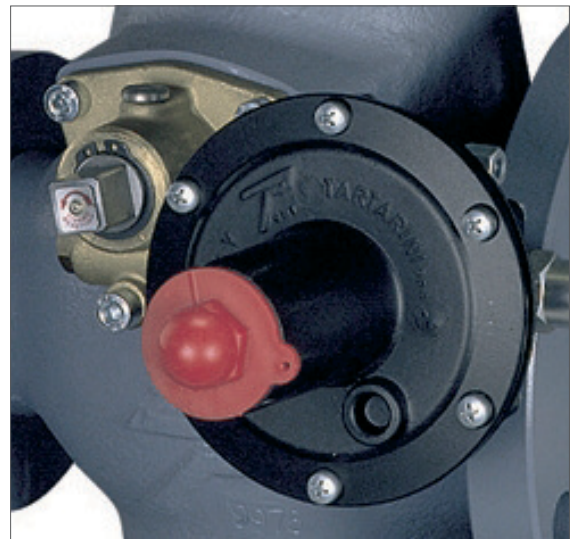

Silencer

Type SR

Built-in multi-path
 Up to 10 dB(A) attenuation



Accessories

PROXIMITY SWITCH

In order to send the slam-shut closing signal, a proximity switch suitable for installation in hazardous area is used.

The use of this switch foresees the application of an intrinsic safety separation barrier which should be installed in safe area.

The distance between the proximity switch and the barrier should be calculated according to the type of gas and installation electrical specifications.

The proximity switch should be positioned at about 0.5 mm from the stem (S).

The adjustment is made by means of adjusting nuts

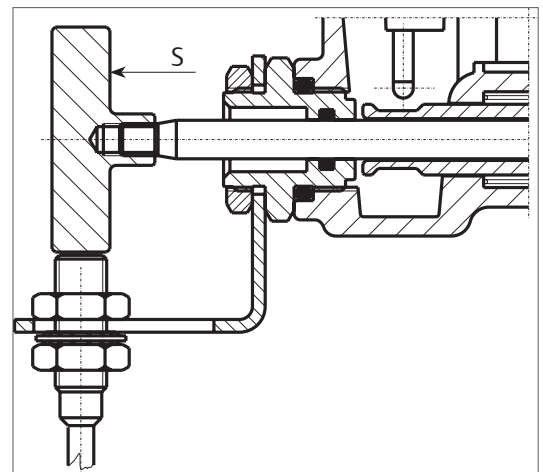

ELECTROVALVE FOR REMOTE CONTROLLED CLOSURE

The OS/66 equipped with a slam-shut device for minimum pressure, can be equipped with a 3-way valve with explosion-proof construction to permit remote-controlled closure.

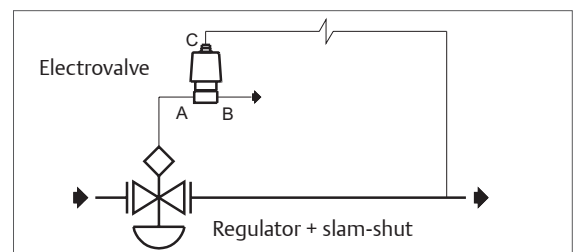

IT/3V THREE-WAY VALVE FOR SETTING CONTROL (P_u max 50 bar)

It allows the OS/66 operation and setting control, without having to change the regulator setting.

The valve is installed on the OS/66 control line and it must be connected to a suitable pressure source that is capable of reaching the settings of the OS/66.

The IT/3V three-way valve is of the spring return type and it is equipped with a safety lock plate (B) on the control knob (Q).

When the plate (B) is pivoted, pressure on the knob (Q) makes it possible to put the sensitive member into communication with a pressure source, thus making it possible to perform operation and setting tests.

Upon completion of the procedures, releasing the knob will reset normal running conditions.

The safety lock plate on the knob prevents accidental maneuvers.

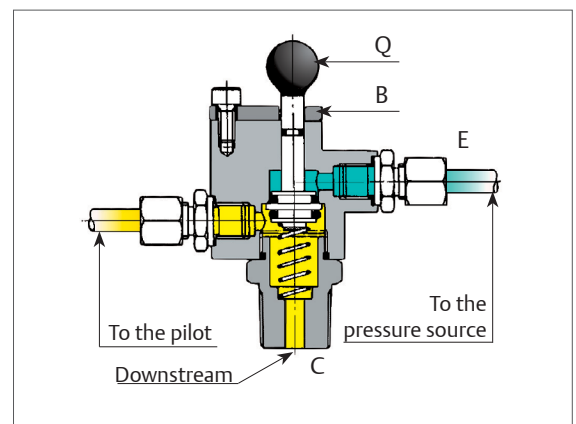

M Regulators

Examples of Connections

MBN/
Series

DN 25 - 65 Internal Impulse Connection

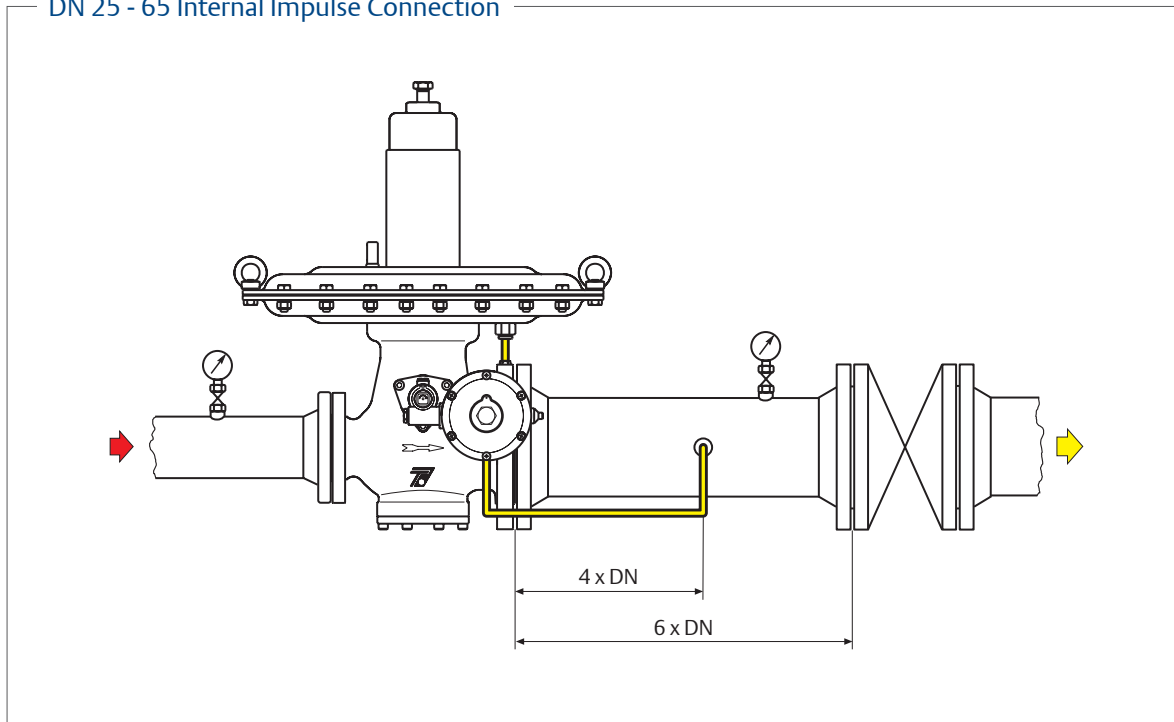

DN 80 - 100 External Impulse Connection

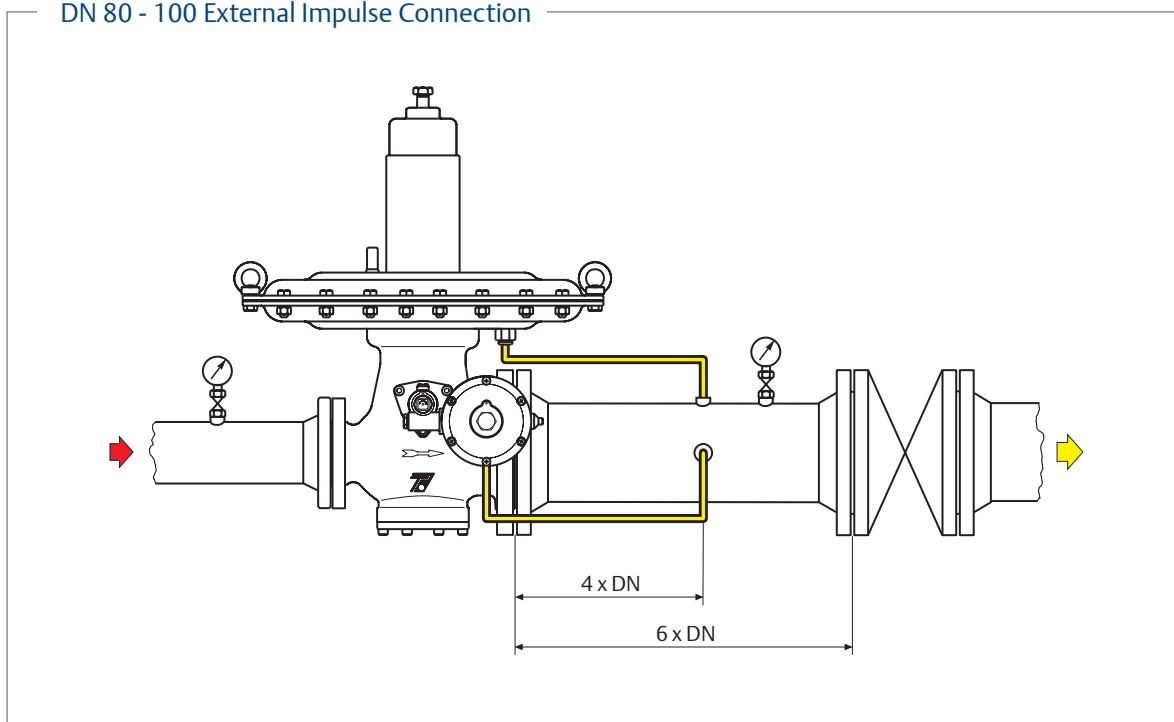

Examples of Connections

MBF-M/
MN/
Series

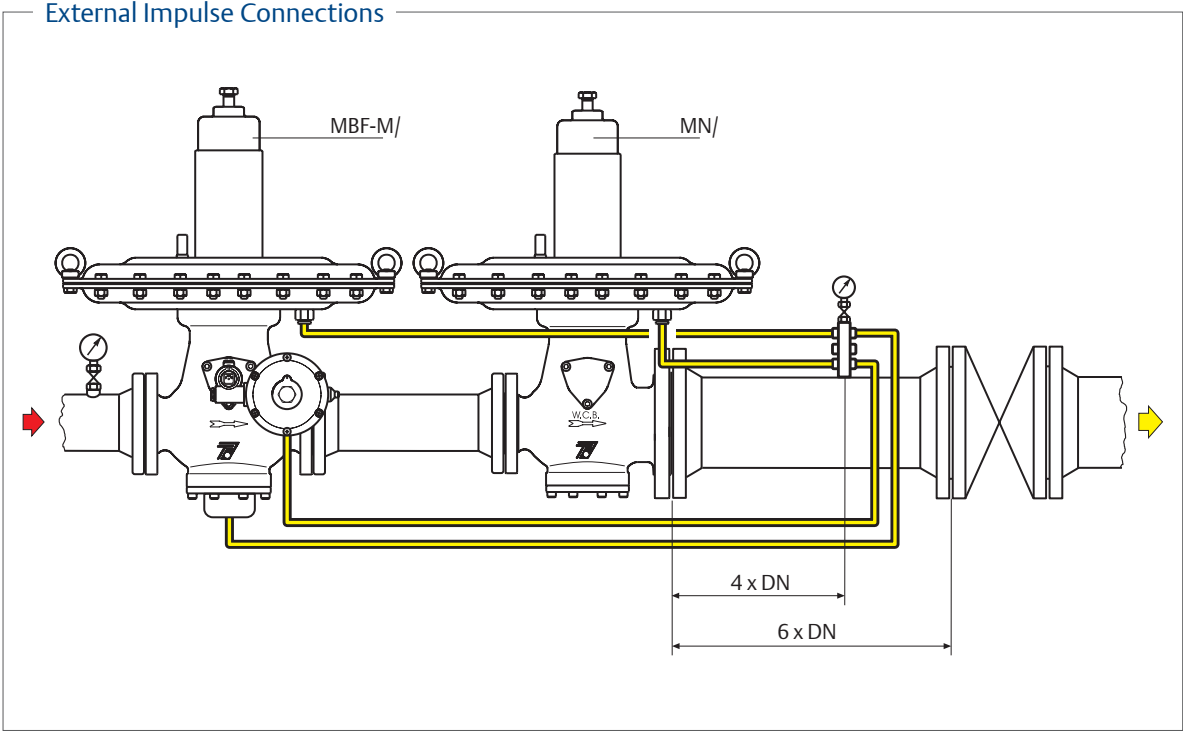

M Regulators

Overall Dimensions (mm) and Weights (kg)

MN, MBN, MBN-M Series

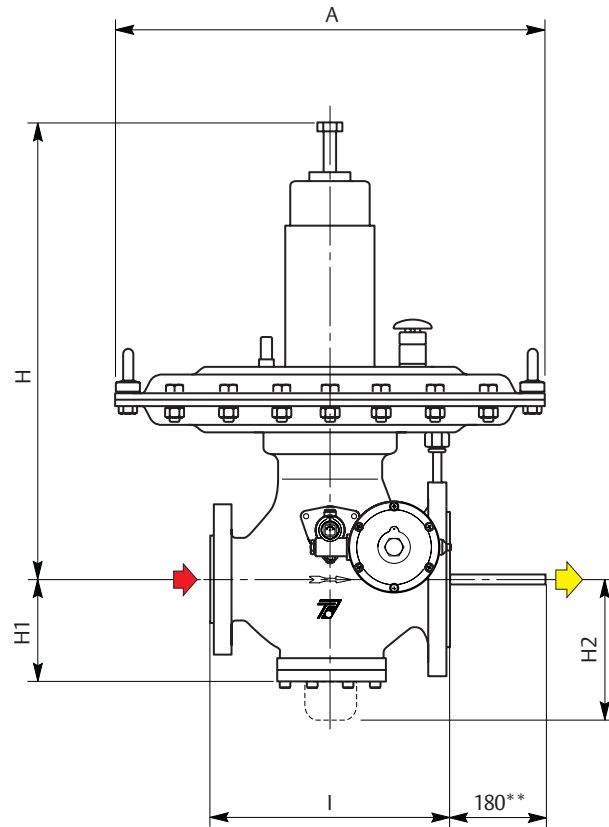

DN	I	A		H	H1	H2 Monitor Version	Weight		
		Standard	AP APA				MN	MBN	MBN-M
25x65	184	380		500	95	140	31	33	37
40x80	222	500	380	580	100	160	53	55	59
50x100	254			600	120	170	59	62	67
65x100	276			620	132	200	62	66	72
80x150	298	500 620*		650	145	215	80	84	90
100x200	352	500 620*	500	660	180	265	125	130	140

(*) For outlet pressure from 20 to 80 mbar only

(**) For models with internal impulse connection only (DN 25-40-50-65)

Overall Dimensions (mm) and Weights (kg)

MF, MBF, MBF-M Series

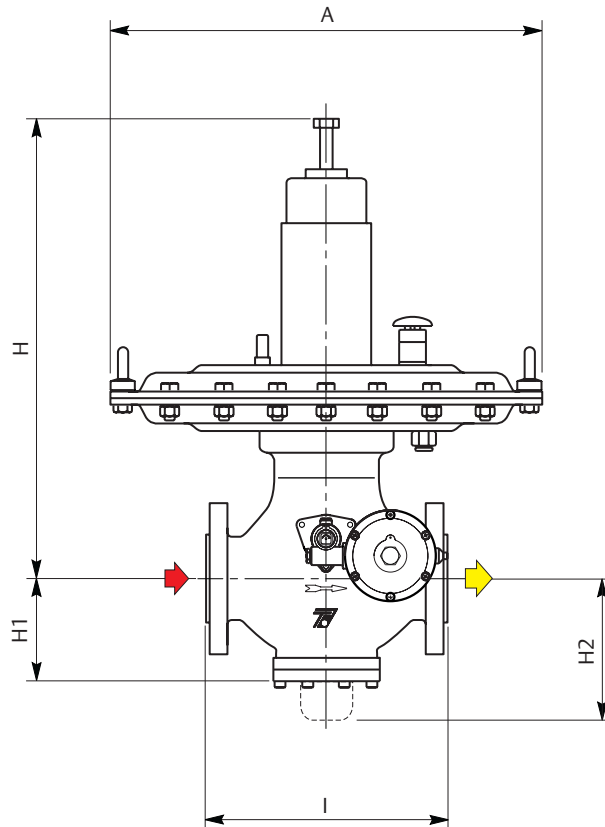

DN	I	A		H	H1	H2 Monitor Version	Weight		
		Standard	AP APA				MF	MBF	MBF-M
25	184	380		500	95	140	27	29	33
40	222	500	380	580	100	160	50	52	56
50	254			600	120	180	55	59	64
80	298	500		620*	650	145	215	73	77
100	352	500	500	660	180	265	110	115	125
		620*							

(*) For outlet pressure from 20 to 80 mbar only

✉ Webadmin.Regulators@emerson.com

🔍 Tartarini-NaturalGas.com

📘 Facebook.com/EmersonAutomationSolutions

🌐 LinkedIn.com/company/emerson-automation-solutions

🐦 Twitter.com/emr_automation

Emerson Automation Solutions

Americas

McKinney, Texas 75070 USA
T +1 800 558 5853
+1 972 548 3574

Europe

Bologna 40013, Italy
T +39 051 419 0611

Asia Pacific

Singapore 128461, Singapore
T +65 6777 8211

Middle East and Africa

Dubai, United Arab Emirates
T +971 4 811 8100

D104050X012 © 2015, 2021 Emerson Process Management Regulator Technologies, Inc. All rights reserved. 01/21.
The Emerson logo is a trademark and service mark of Emerson Electric Co. All other marks are the property of their prospective owners.
Tartarini™ is a mark owned by one of the companies in the Emerson Automation Solutions business unit of Emerson Electric Co.

The contents of this publication are presented for informational purposes only, and while every effort has been made to ensure their accuracy, they are not to be construed as warranties or guarantees, express or implied, regarding the products or services described herein or their use or applicability. All sales are governed by our terms and conditions, which are available upon request. We reserve the right to modify or improve the designs or specifications of such products at any time without notice.

Emerson Process Management Regulator Technologies, Inc does not assume responsibility for the selection, use or maintenance of any product. Responsibility for proper selection, use and maintenance of any Emerson Process Management Regulator Technologies, Inc. product remains solely with the purchaser.

Emerson Process Management s.r.l.

Emerson Automation Solutions - Stabilimento di/Site of: Castel Maggiore - Bologna
Sede Legale/Legal Entity: Piazza Meda 5, 20121 Milano, Italy
Sede Amministrativa/Administrative Headquarters: OMT Tartarini, Via Clodoveo Bonazzi 43,
40013 Castel Maggiore (Bologna), Italy
C.F. - P.I. e R.I. di MI 13186130152 - REA di MI/n.1622916
Direz. e Coord. (art. 2497 bis CC): EMERSON ELECTRIC CO. St. Louis (USA) Socio Unico

