

Type BM9 Slam-Shut Valve

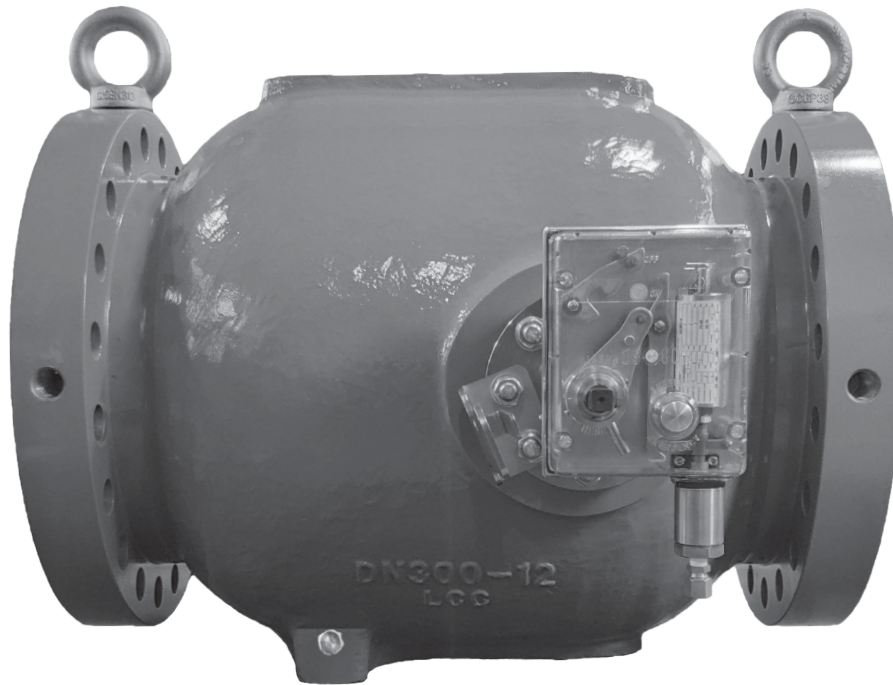

Figure 1. Type BM9 Slam-Shut Valve

Features

- **Single-piece, integral flanged and ergonomic design of anti rolling feature in the body**
- **Fully balanced plug design for lower actuation forces**
- **Can monitor overpressure and/or underpressure in a single stream or in other points of a gas station**
- **Push-button manual emergency release**
- **Manual reset through rotation of the reset shaft only**
- **No external by-pass**
- **Ease of maintenance through modular design**
- **Radial seal design resulting in low fluid velocity around the seating surfaces to reduce flow wearing**

Introduction

Type BM9 slam-shut valve is an axial flow type, automatic shut-off device suitable for installation as safety device in regulating, distribution and transmission stations of suitably filtered natural gas.

Type BM9 is designed to be used with fuel gases of 1st and 2nd family according to EN 437, and with other non aggressive and non fuel gases. For any other gases, other than natural gas, please contact your local sales office.

The slam-shut valve has the task to quickly shut off the gas flow when the pressure in control point(s) reaches a fixed set value.

Type BM9

Specifications

The Specifications section gives some general specifications for the Type BM9 slam-shut valve. The nameplates give detailed information for a particular slam-shut valve as built in the factory.

Body Sizes and End Connection Styles

DN 200 / NPS 8: CL300 RF and CL600 RF
DN 250 / NPS 10: CL300 RF and CL600 RF
DN 300 / NPS 12: CL300 RF and CL600 RF

Maximum Allowable Pressure (PS)⁽¹⁾

CL300 RF: 51.7 barg / 750 psig
CL600 RF: 103 barg / 1500 psig

Inlet Operating Pressure Range (b_{Pu})⁽²⁾

CL300 RF: 0 to 51.7 barg / 0 to 750 psig
CL600 RF: 0 to 100 barg / 0 to 1450 psig⁽²⁾

Overpressure Set Ranges(W_{do})⁽¹⁾

CL300 RF: 0.5 to 50 barg / 7.25 to 725 psig
CL600 RF: 0.5 to 90 barg / 7.25 to 1305 psig

Underpressure Set Ranges(W_{du})⁽¹⁾

CL300 RF: 0.3 to 50 barg / 4.35 to 725 psig
CL600 RF: 0.3 to 80 barg / 4.35 to 1160 psig

Temperature Classes (TS)⁽²⁾

Class 1: -10 to 60°C / 14 to 140°F
Class 2: -20 to 60°C / -4 to 140°F

Working Temperature Capabilities⁽²⁾

Standard Version, Nitrile (NBR) or Fluorocarbon (FKM): -10 to 60°C / 14 to 140°F
Low Temperature Version, Nitrile (NBR): -20 to 60°C / -4 to 140°F

Slam Shut Controller

OS9/80X Series (a sub-family of OS/80X Series)

Flow Coefficient

	DN 200 / NPS 8	DN 250 / NPS 10	DN 300 / NPS 12
C_g	37,890	61,200	83,087
C_1	30	32.5	31
C_v	1,260	1,883	2,680
X_1	0.57	0.67	0.61
F_d	0.313	0.345	0.355
F_1	0.8	0.85	0.89

Accuracy Class (AG)

Up to $\pm 1\%$

Response Time (t_a)

≤ 1 second

Construction Materials

Body: LCC Steel
Sleeve: Steel
O-ring: Nitrile (NBR) (standard) or Fluorocarbon (FKM) (optional)
Disk: Polytetrafluoroethylene (PTFE)
Controller: See Table 5

Approximate Weights

CL300 RF

DN 200 / NPS 8: 313 kg / 690 lbs
DN 250 / NPS 10: 508 kg / 1120 lbs
DN 300 / NPS 12: 790 kg / 1742 lbs

CL600 RF

DN 200 / NPS 8: 351 kg / 774 lbs
DN 250 / NPS 10: 590 kg / 1301 lbs
DN 300 / NPS 12: 870 kg / 1918 lbs

Optional Accessories

Proximity Switch for remote monitoring
Solenoid Valve for remote-controlled closure
Three-way Valve for setting control
Wireless Position Monitor

1. The pressure/temperature limits in this Bulletin or any applicable standard limitation should not be exceeded.

2. In accordance with EN14382 Standard.

Table 1. Overpressure Shut-off Spring Ranges and Information

CONTROLLER TYPE	SPRING RANGE		RESET DIFFERENTIAL, ΔP_{wo}		SPRING WIRE DIAMETER		SPRING LENGTH		PART NUMBER	MATERIAL	SPRING COLOR
	bar	psig	bar	psig	mm	In.	mm	In.			
OS9/80X-MPA-D-R	0.50 to 0.70	7.25 to 10.15	0.15	2.17	3.00	0.12	75.0	2.95	M0105140X12	Steel	Yellow
	0.70 to 2.50	10.15 to 36.25	0.30	4.35	4.00	0.16	75.0	2.95	M0197070X12	Steel	Blue
	2.50 to 5.00	36.25 to 72.51	0.50	7.25	5.00	0.20	75.0	2.95	M0197080X12	Steel	Red
OS9/80X-APA-D-R	2 to 4	29 to 58	0.40	5.80	4.00	0.16	75.0	2.95	M0197070X12	Steel	Blue
	4 to 10	58 to 145	1	14.50	5.00	0.20	75.0	2.95	M0197080X12	Steel	Red
OS9/84X-R	5.0 to 25	72 to 362	3	43.50	4.00	0.16	75.0	2.95	M0197070X12	Steel	Blue
	24 to 41	348 to 594	5	72.50	5.00	0.20	75.0	2.95	M0197080X12	Steel	Red
OS9/88X-R	18 to 50	261 to 725	8	116.00	3.00	0.12	75.0	2.95	M0105140X12	Steel	Yellow
	40 to 80	580 to 1160	12	174.00	4.00	0.16	75.0	2.95	M0197070X12	Steel	Blue
	70 to 90	1088 to 1305	15	217.50	5.00	0.20	75.0	2.95	M0197080X12	Steel	Red
OS9/80X-R-PN + PRX/182-PN	0.5 to 1.1	7.3 to 16	0.2	2.90	2.50	0.10	51	2.01	M0255250X12	Steel	White
	1 to 1.8	14.5 to 26	0.3	4.35	2.80	0.11	55	2.17	M0255240X12	Steel	Yellow
	1.6 to 3	23 to 44	0.3	4.35	3.20	0.13	55	2.17	M0255230X12	Steel	Green
	2.8 to 5.5	41 to 80	0.4	5.80	3.50	0.14	55	2.17	M0255180X12	Steel	Blue
	5 to 8.5	73 to 123	0.4	5.80	4.00	0.16	55	2.17	M0255220X12	Steel	Black
	8 to 14.5	116 to 210	0.5	7.25	4.50	0.18	55	2.17	M0255210X12	Steel	Silver
	14 to 23	203 to 334	0.6	8.70	5.50	0.22	51	2.01	M0255200X12	Steel	Gold
	22 to 30	319 to 435	0.6	8.70	6.00	0.24	51	2.01	M0255860X12	Steel	Aluminum
29 to 42	421 to 609	0.6	8.70	6.50	0.26	50	1.97	M0255190X12	Steel	Red	
OS9/84X-R-PN + PRX-AP/182-PN	30 to 80	435 to 1160	0.8	11.60	8.50	0.33	100	3.94	M0273790X12	Steel	Neutral

Table 2. Underpressure Shut-off Spring Ranges and Information

CONTROLLER TYPE	SPRING RANGE		RESET DIFFERENTIAL, ΔP_{wu}		SPRING DIAMETER		SPRING LENGTH		PART NUMBER	MATERIAL	SPRING COLOR
	bar	psig	bar	psig	mm	In.	mm	In.			
OS9/80X-MPA-D-R	0.3 to 0.40	4.35 to 5.80	0.15	2.17	1.75	0.07	60.0	2.36	M0174340X12	Steel	Yellow
	0.40 to 0.90	5.80 to 13.05	0.30	4.35	2.25	0.09	60.0	2.36	M0197060X12	Steel	Blue
	0.90 to 4	13.05 to 58.01	0.70	10.15	3.00	0.12	60.0	2.36	M0197820X12	Steel	Red
OS9/80X-APA-D-R	0.3 to 0.8	4.35 to 11.6	0.25	3.62	1.75	0.07	60.0	2.36	M0174340X12	Steel	Yellow
	0.8 to 2.0	11.6 to 29	0.50	7.25	2.25	0.09	60.0	2.36	M0197060X12	Steel	Blue
	2.0 to 7.0	29 to 101.52	1.50	21.7	3.00	0.12	60.0	2.36	M0197820X12	Steel	Red
OS9/84X-R	4.0 to 8.0	58.01 to 116.03	3	43.50	2.25	0.09	60.0	2.36	M0197060X12	Steel	Blue
	7.0 to 16	101.52 to 232.06	6	87.00	3.00	0.12	60.0	2.36	M0197820X12	Steel	Red
OS9/88X-R	8.0 to 30	116.03 to 435.11	8	116.00	1.75	0.07	60.0	2.36	M0174340X12	Steel	Yellow
	20 to 70	290.07 to 1015.26	15	217.50	2.25	0.09	60.0	2.36	M0197060X12	Steel	Blue
OS9/80X-R-PN + PRX/181-PN	0.5 to 1.1	7.3 to 16	0.3	4.35	2.50	0.10	51	2.01	M0255250X12	Steel	White
	1 to 1.8	14.5 to 26	0.4	5.80	2.80	0.11	55	2.17	M0255240X12	Steel	Yellow
	1.6 to 3	23 to 44	0.4	5.80	3.20	0.13	55	2.17	M0255230X12	Steel	Green
	2.8 to 5.5	41 to 80	0.6	8.70	3.50	0.14	55	2.17	M0255180X12	Steel	Blue
	5 to 8.5	73 to 123	0.6	8.70	4.00	0.16	55	2.17	M0255220X12	Steel	Black
	8 to 14.5	116 to 210	0.6	8.70	4.50	0.18	55	2.17	M0255210X12	Steel	Silver
	14 to 23	203 to 334	0.8	11.60	5.50	0.22	51	2.01	M0255200X12	Steel	Gold
	22 to 30	319 to 435	0.8	11.60	6.00	0.24	51	2.01	M0255860X12	Steel	Aluminum
29 to 42	421 to 609	0.8	11.60	6.50	0.26	50	1.97	M0255190X12	Steel	Red	
OS9/84X-R-PN + PRX-AP/181-PN	30 to 80	435 to 1160	1	14.50	8.50	0.33	100	3.94	M0273790X12	Steel	Neutral

Type BM9

Table 3. OS9/80X-R Series Spring-Loaded Pneumatic Slam-Shut Controller Pressure Rating

TYPE	MAXIMUM ALLOWABLE PRESSURE		OVERPRESSURE SET RANGE, W_{do}				UNDERPRESSURE SET RANGE, W_{du}				BODY MATERIAL
			Minimum		Maximum		Minimum		Maximum		
	bar	psig	bar	psig	bar	psig	bar	psig	bar	psig	
OS9/80X-MPA-D-R	100	1450	0.5	7.25	5	72.5	0.3	4.35	4	58	Steel
OS9/80X-APA-D-R			2	29	10	145	0.3	4.35	7	102	
OS9/84X-R			5	72.5	41	595	4	58	16	232	Brass
OS9/88X-R			18	261	90	1305	8	116	70	1015	

N.B.: 1/4 NPT female threaded connections

Table 4. OS9/80X-R Series Pilot-Loaded Slam-Shut Controller with Type PRX Pilot Pressure Rating

TYPE	MAXIMUM ALLOWABLE PRESSURE		OVERPRESSURE SET RANGE, W_{do}				UNDEPRESSURE SET RANGE, W_{du}				BODY MATERIAL
			Minimum		Maximum		Minimum		Maximum		
	bar	psig	bar	psig	bar	psig	bar	psig	bar	psig	
OS9/80X-R-PN ⁽¹⁾	100	1450	0.5	7.25	40	580	0.5	7.25	40	580	Steel
OS9/84X-R-PN ⁽²⁾			30	435	80	1160	30	435	80	1160	Brass

1. Made of a Type OS9/80X-APA-D-R set at about 0.4 bar / 5.80 psig and Type PRX/182-PN pilots for overpressure and Type PRX/181-PN for underpressure.
2. Made of a Type OS9/84X-R set at about 20 bar / 290 psig and Type PRX-AP/182-PN pilots for overpressure and Type PRX-AP/181-PN for underpressure.

Table 5. Controller/Pilot Construction Materials

CONTROLLER/PILOT TYPE	MATERIAL		
	Body	Diaphragm	O-ring
OS9/80X-MPA-D-R	Steel	Fabric-finished Nitrile (NBR) or Fluorocarbon (FKM)	Nitrile (NBR) or Fluorocarbon (FKM)
OS9/80X-APA-D-R			
OS9/84X-R	Brass	Lip Seal: PTFE	
OS9/88X-R			
PRX/181/182-PN	Brass	Fabric-finished Nitrile (NBR) or Fluorocarbon (FKM)	
PRX-AP/181/182-PN			

Product Description

Main Valve

Type BM9 slam-shut valve uses the pipeline gas pressure for its operation and therefore, it does not require any external energy to operate.

It has a sleeve-type valve, therefore does not need any external by-pass to facilitate the opening of the valve.

Controller

OS9/80X Series is a sub-family of OS/80X Series. It is a modified version of OS/80X Series to suit Type BM9 slam shut valve. All components/parts between OS and OS9 Series are identical except for:

- The shaft and holder of OS9/80X Series are reinforced.

Type BM9 slam shut valve is operated by either OS9/80X-R or OS9/80X-R-PN Series controller.

OS9/80X Series controller is available in different types according to set ranges required. See Tables 1 and 2 for details.

The OS9/80X-R-PN Series controller is supplied in two types:

1. Type OS9/80X-R-PN: Pressure range is 0.5 to 40 bar / 7.25 to 580 psig. This controller is made up of Type OS9/80X APA D-R controller which is set at about 0.4 bar / 5.80 psig and Type PRX/182-PN pilot for overpressure and Type PRX/181-PN for underpressure.
2. Type OS9/84X-R-PN: Pressure range is 30 to 80 bar / 435 to 1160 psig. This controller is made of Type OS9/84X-R set at about 20 bar / 290 psig and Type PRX/182-PN pilot for overpressure and Type PRX/181-PN for underpressure.

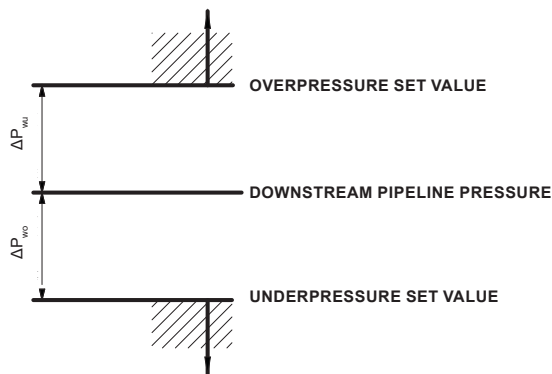

Figure 2. OS9/80X Series Slam-Shut Controller Range Setting

Types PRX/182-PN and PRX/181-PN pilots are available in different set pressure ranges to suit the application needs.

The -PN Series controllers are used when the required reset differential pressures (ΔP_{wo} and ΔP_{wu}) are much lower than the standard controller's reset differential pressures.

The -PN series controllers also have better accuracy than the standard controller.

Range Setting

The reset differential indicates the minimum value to be considered with respect to the line set point for proper resetting of the controller.

Example: Downstream pipeline pressure set point is 15 bar / 218 psig.

Choose Type OS9/84X-R with blue spring for overpressure and red spring for underpressure, see Tables 1 and 2. The reset differential ΔP_{wo} is 3.0 bar / 43.5 psig and ΔP_{wu} is 6.0 bar / 87.0 psig.

So the overpressure set value should be 18 bar / 261 psig (15 bar + 3 bar = 18 bar or 218 psig + 43.5 psig = 261 psig) or higher, and underpressure set value should be 9.0 bar / 131 psig (15 bar - 6 bar = 9 bar or 218 psig - 87 psig = 131 psig) or lower.

Accessories

Proximity Switch

In order to send the shut-off opening/closing signal, a proximity switch suitable for installation in hazardous area is used.

The use of this switch foresees the application of an intrinsic safety separation barrier which should be installed in safe area.

The distance between the proximity switch and the barrier should be calculated according to the type of gas and installation electrical specifications.

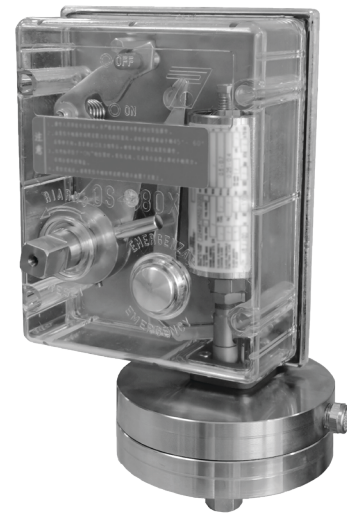

Figure 3. OS9/80X Series Slam-Shut Controller

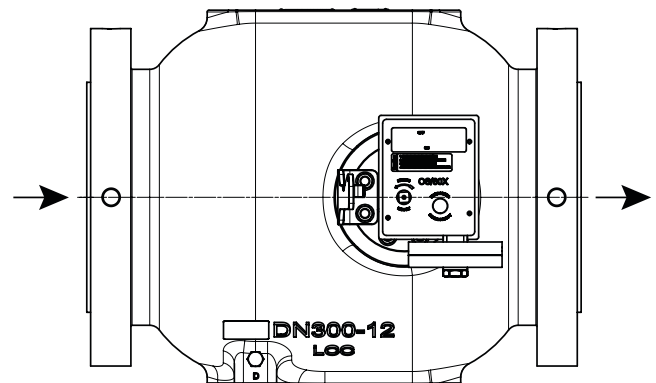

Figure 4. Type BM9 Slam-Shut Valve Flow Orientation



Figure 5. Proximity Switch

Type BM9

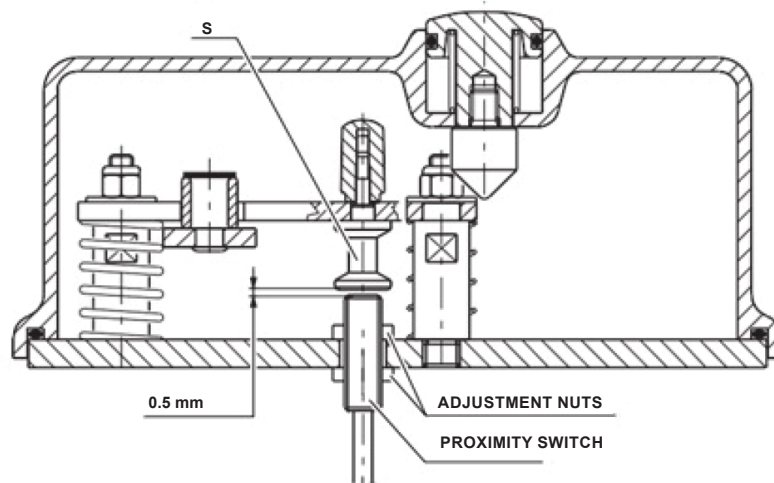

Figure 6. Proximity Switch Installation

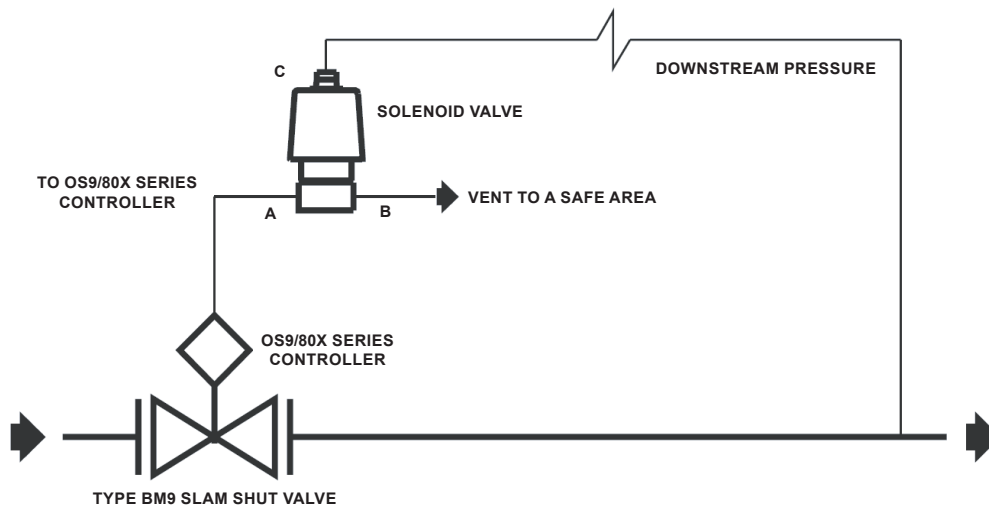

Figure 7. Solenoid Valve Installation

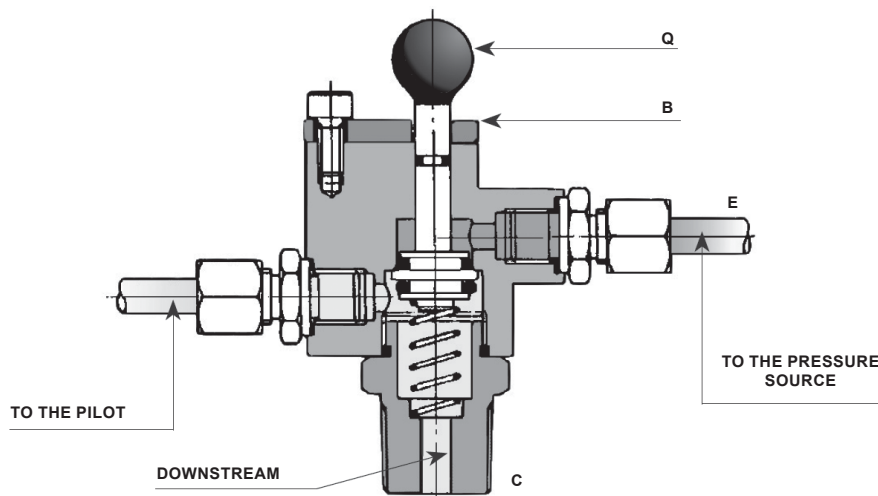

Figure 8. IT/3V Three-way Valve Installation

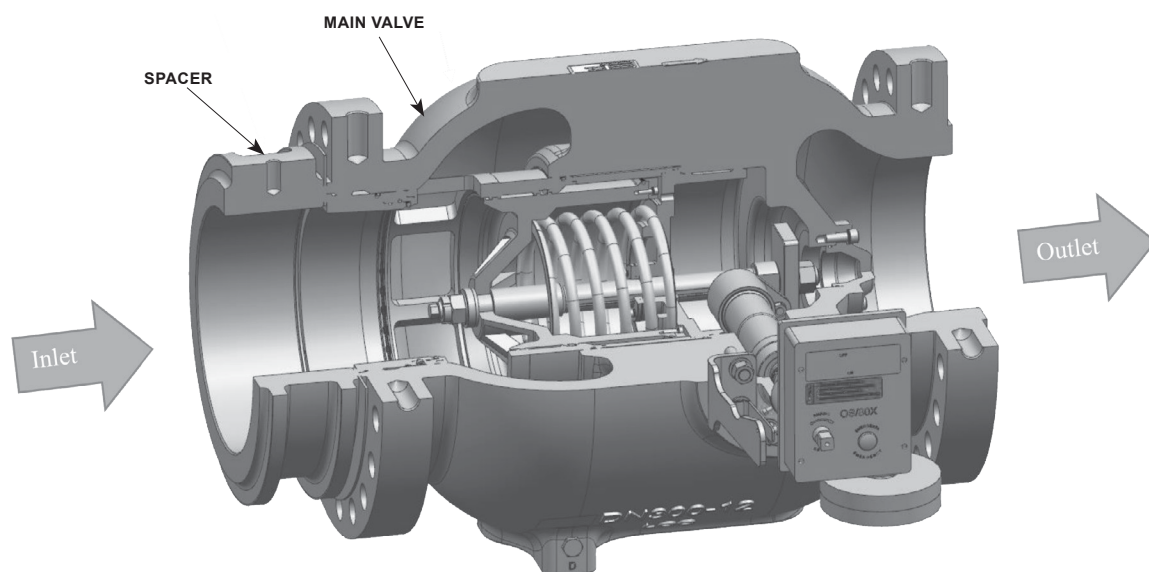

Figure 9. Type BM9 Main Valve Cross Section

The proximity switch should be positioned at about 0.5 mm / 0.02 in. from the stem (S).

The adjustment is made by means of adjusting nuts.

On request, the controller can be equipped with two proximity switches to sense open and close positions of the slam shut valve.

Solenoid Valve for Remote Controlled Closure

The Types OS/80X-R and the OS/80X-R-PN equipped with a shut-off device for minimum pressure, can be equipped with a three-way valve with explosion-proof construction to permit remote-controlled closure. See Figure 7.

IT/3V Three-Way Valve for Setting Control (Pu max 50 bar / 725 psig)

It allows the Type OS/80X-R operation and setting control, without having to change the regulator setting.

The valve is installed on the Type OS/80X-R control line and it must be connected to a suitable pressure source that is capable of reaching the settings of the Type OS/80X-R.

The IT/3V three-way valve is of the spring-return type and it is equipped with a safety lock plate (B) on the control knob (Q).

When the plate (B) is pivoted, pressure on the knob (Q) makes it possible to put the sensitive member into communication with a pressure source, thus making it possible to perform operation and setting tests. See Figure 8.

Upon completion of the procedures, releasing the knob will reset normal running conditions. The safety lock plate on the knob prevents accidental maneuvers.

Principle of Operation

Type BM9 slam-shut valves are used to prevent overpressure, underpressure or both overpressure and underpressure in the system. This slam-shut valve is a combination of an axial flow valve and an OS/80X Series slam-shut controller which keeps the valve open.

Type BM9 has a shutter valve which slides axially. With this design, by-pass is not needed for it to open even with the presence of pressurized gas.

When the control pressure is within the set value of the slam-shut controller, the controller prevents the rotation of the eccentric shaft and the valve remains open.

When the control pressure is above or below the set value, the slam-shut controller releases the eccentric shaft closing the slam-shut valve.

The slam-shut controller is provided with a manual release push-button to quickly close the slam-shut valve in case of emergency or during maintenance/checking operations.

Type BM9 can be used with pilot. Supply to pilot comes from the downstream of the slam-shut valve.

Type BM9

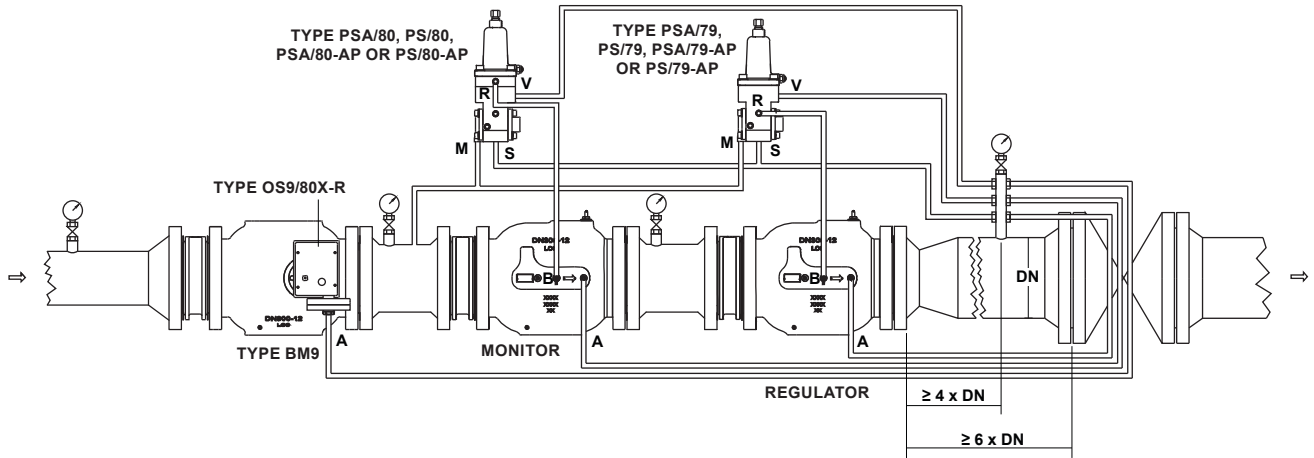

TYPES PSA/79, PS/79, PSA/80, PS/80, PSA/79-AP, PS/79-AP, PSA/80-AP AND PS/80-AP:
 V - SENSING PORT
 M - SUPPLY PORT
 R - LOADING PORT
 S - BLEED PORT

TYPE FLR:
 A - SENSING PORT
 B - LOADING PORT

SLAM-SHUT VALVE WITH TYPE OS9/80X-R CONTROLLER – INSTALLATION IN WIDE-OPEN MONITOR LINE

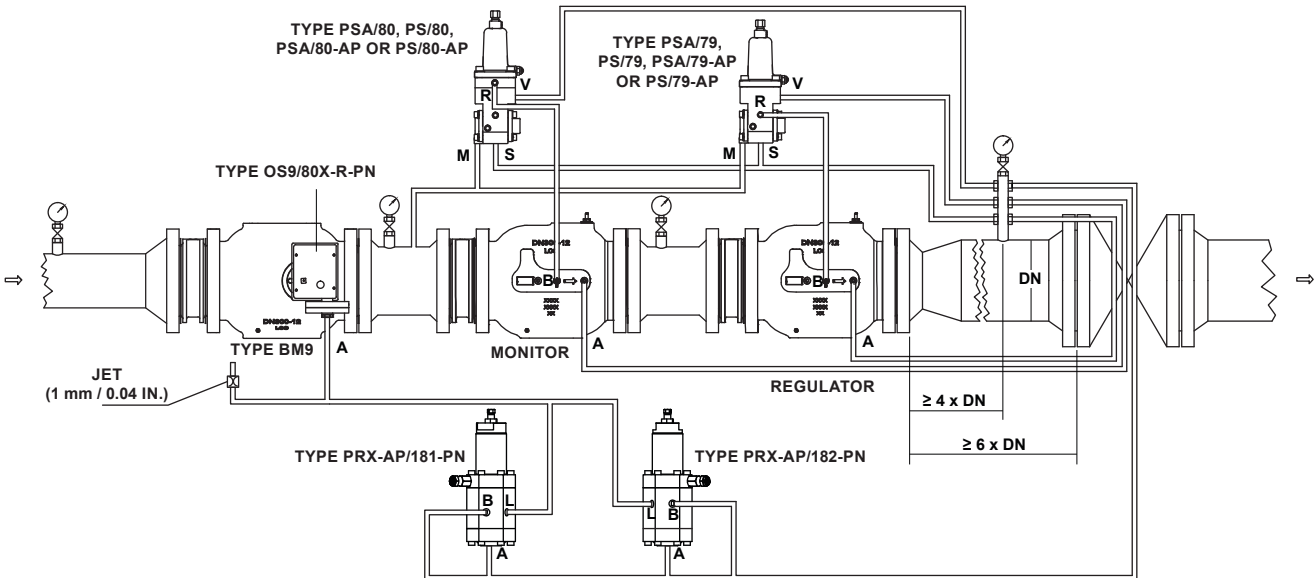

PRX SERIES:
 B - SUPPLY PORT
 L - LOADING PORT
 A - SENSING PORT

TYPES PSA/79, PS/79, PSA/80, PS/80, PSA/79-AP, PS/79-AP, PSA/80-AP AND PS/80-AP:
 V - SENSING PORT
 M - SUPPLY PORT
 R - LOADING PORT
 S - BLEED PORT

TYPE FLR:
 A - SENSING PORT
 B - LOADING PORT

SLAM-SHUT VALVE WITH TYPE OS9/80X-R-PN CONTROLLER – OVERPRESSURE AND UNDERPRESSURE CONTROL IN WIDE-OPEN MONITOR SYSTEM

Figure 10. Type BM9 Installation Schematics

Table 6. Gas Conversion

GAS	RELATIVE DENSITY (d)	FACTOR (F)
Air	1	0.78
Butane	2.01	0.55
Propane	1.53	0.63
Nitrogen	0.97	0.79

Installation

Install Type BM9 in a horizontal position and ensure the flow through the body is in the direction indicated by the arrow on the body. See Figure 4.

Ensure that the data found on the slam-shut valve label are compatible with usage requirements.

Make sure that slam-shut controller is installed up right.

Make the connection of the pressure control pipe, taking it off a straight section of the downstream pipe, if possible, far from narrow sections, curves or branches, to avoid variations in the release values of slam-shut device caused by turbulence.

Clean the gas by installing filters or scrubbers upstream of the Type BM9 to avoid abrasion and/or erosion on pressure containing parts.

Ensure that gas is dry. If the gas is not dry, install gas-liquid separator upstream of the Type BM9 and install a heating device on Type BM9.

Capacity Information

To find approximate flow capacity and valve diameter, perform the following procedures:

Calculation Procedures

The following formulas refer to normal operating conditions in a sub-critical state with: $P_2 > \frac{P_1}{2}$

Symbols

Q = Natural gas flow rate in (Stm³/h)

P₁ = Absolute inlet pressure in bar

P₂ = Absolute outlet pressure in bar

C_g = Flow coefficient

C₁ = Body shape factor

d = Relative density of the gas

Flow Rate Q

$$Q = 0.525 \times C_g P_1 \text{SIN} \left(\frac{3417}{C_1} \sqrt{\frac{\Delta P}{P_1}} \right) \text{DEG}$$

$$Q = 0.525 \times C_g P_1$$

For other gases with different densities, the flow rate calculated with the above formulas must be multiplied with the correction factor:

$$F = \sqrt{\frac{0.6}{d}}$$

Power Loss ΔP

$$\Delta P = \frac{P_1 - \sqrt{P_1^2 - 4 \left(\frac{Q}{C_g \times 1.05} \right)^2}}{2}$$

DN Sizes

Calculate the required C_g with the following formula:

The above formulas apply to natural gas flow rate only. If the flow rate value (Q) refers to other gasses, divide it by the correction factor F. See Table 6.

$$C_g = \frac{Q}{0.525 \times P_1 \text{SIN} \left(\frac{3417}{C_1} \sqrt{\frac{\Delta P}{P_1}} \right) \text{DEG}}$$

Choose the slam-shut valve with the C_g higher than the calculated value. After having determined the slam-shut valve diameter, it is suggested to check that the velocity on the seal seat is not higher than 80 m/s by using the following formula:

$$V = 345.92 \times \frac{Q}{DN^2} \times \frac{1 - 0.002 \times P_u}{1 + P_u}$$

V = velocity (m/s)

345.92 = Numerical

Q = Natural gas flow rate in (Stm³/h)

DN = Valve nominal diameter (mm)

P_u = Inlet pressure in relative value (bar)

In case of velocities higher than indicated limits, increase the valve diameter.

Type BM9

Dimensions and Weights

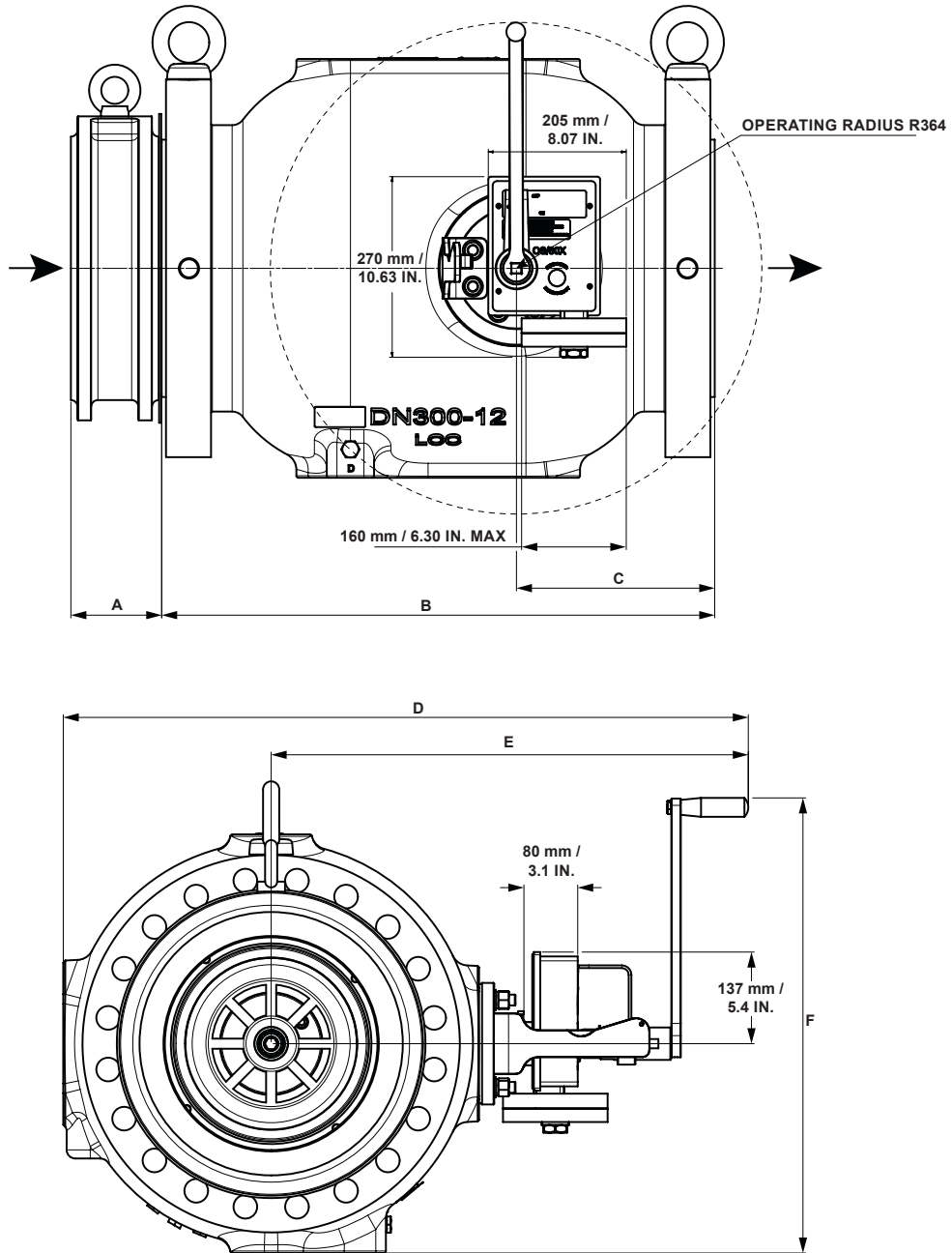

Figure 11. Type BM9 Dimensions

Table 7. Type BM9 Dimensions and Weights

BODY SIZE DN / NPS	END CONNECTION	A		B		C		D		E		F		WEIGHT	
		mm	In.	mm	In.	mm	In.	mm	In.	mm	In.	mm	In.	kg	lbs
200 / 8	CL300 RF	125	4.92	568	22.36	204	8.03	849	33.43	625	24.61	585	23.03	313	690
	CL600 RF	125	4.92	610	24.02	225	8.86							351	774
250 / 10	CL300 RF	130	5.12	708	27.87	251	9.88	938	36.93	665	26.18	630	24.80	508	1120
	CL600 RF	130	5.12	752	29.61	273	10.75							590	1301
300 / 12	CL300 RF	135	5.31	775	30.51	272	10.71	1013	39.88	705	27.76	675	26.57	790	1742
	CL600 RF	135	5.31	819	32.24	294	11.57							870	1918

N.B. The threaded opening for the connection of the control line is 1/4 NPT female.

Ordering Information

When ordering, complete the ordering guide on this page. Refer to the Specifications section on page 2. Review the description to the right of each

specification and the information in each referenced table or figure. Specify your choice whenever a selection is offered.

Ordering Guide

Body Size

- DN 200 / NPS 8***
- DN 250 / NPS 10***
- DN 300 / NPS 12***

End Connection

- CL300 RF Flanged***
- CL600 RF Flanged***

Controller Type (Select One)

- Type OS9/80X-MPA-D-R***
- Type OS9/80X-APA-D-R***
- Type OS9/84X-R***
- Type OS9/88X-R***
- Type OS9/80X-R-PN***
- Type OS9/84X-R-PN***

O-ring Material

Standard (-10 to 60°C / 14 to 140°F)

- Nitrile (NBR)***
- Fluorocarbon (FKM)***

Low Temperature (-20 to 60°C / -4 to 140°F)

- Nitrile (NBR)***

Options

- Proximity Switch**
- Solenoid Valve**
- IT/3V Three-way Valve**
- Wireless Position Monitor**

Slam-Shut Trip Pressure Setting (Select One)

- Overpressure (OPSO) trip only
Indicate Overpressure Trip Point _____
- Underpressure (UPSO) trip only
Indicate Underpressure Trip Point _____
- Over and Underpressure (OPSO/UPSO) trip
Indicate Overpressure Trip Point _____
Indicate Underpressure Trip Point _____

Slam-Shut Valve Quick Order Guide	
***	Readily Available for Shipment
**	Allow Additional Time for Shipment
*	Special Order, Constructed from Non-Stocked Parts. Consult Your local Sales Office for Availability.
Availability of the product being ordered is determined by the component with the longest shipping time for the requested construction.	

Specification Worksheet	
Application:	
Specific Use	_____
Line Size	_____
Gas Type and Specific Gravity	_____
Gas Temperature	_____
Pressure:	
Maximum Inlet Pressure (P_{1max})	_____
Minimum Inlet Pressure (P_{1min})	_____
Downstream Pressure Setting(s) (P_2)	_____
Maximum Flow (Q_{max})	_____
Performance Required:	
Accuracy Requirements?	_____
Need for Extremely Fast Response?	_____
Other Requirements: _____	

Type BM9

✉ Webadmin.Regulators@emerson.com

🔍 Tartarini-NaturalGas.com

📘 Facebook.com/EmersonAutomationSolutions

🌐 LinkedIn.com/company/emerson-automation-solutions

🐦 Twitter.com/emr_automation

Emerson Automation Solutions

Americas

McKinney, Texas 75070 USA
T +1 800 558 5853
+1 972 548 3574

Asia Pacific

Singapore 128461, Singapore
T +65 6777 8211

Europe

Bologna 40013, Italy
T +39 051 419 0611

Middle East and Africa

Dubai, United Arab Emirates
T +971 4 811 8100

D104475X012 © 2019, 2021 Emerson Process Management Regulator Technologies, Inc. All rights reserved. 06/21.

The Emerson logo is a trademark and service mark of Emerson Electric Co. All other marks are the property of their prospective owners. Tartarini™ is a mark owned by one of the companies in the Emerson Automation Solutions business unit of Emerson Electric Co.

The contents of this publication are presented for informational purposes only, and while every effort has been made to ensure their accuracy, they are not to be construed as warranties or guarantees, express or implied, regarding the products or services described herein or their use or applicability. All sales are governed by our terms and conditions, which are available upon request. We reserve the right to modify or improve the designs or specifications of such products at any time without notice.

Emerson Process Management Regulator Technologies, Inc does not assume responsibility for the selection, use or maintenance of any product. Responsibility for proper selection, use and maintenance of any Emerson Process Management Regulator Technologies, Inc. product remains solely with the purchaser.

Emerson Process Management s.r.l

Emerson Automation Solutions - Stabilimento di/Site of: Castel Maggiore - Bologna
Sede Legale/Legal Entity: Piazza Meda 5, 20121 Milano, Italy
Sede Amministrativa/Administrative Headquarters: OMT Tartarini, Via Clodoveo Bonazzi 43,
40013 Castel Maggiore (Bologna), Italy
C.F. - P.I. e R.I. di MI 13186130152 - REA di MI/n.1622916
Direz. e Coord. (art. 2497 bis CC): EMERSON ELECTRIC CO. St. Louis (USA) Socio Unico

