

May 2020

BM6X Series Slam-Shut Valve

SUMMARY

Introduction	1
PED Categories and Fluid Group	2
Characteristics	2
Labelling	2
Overpressure Protection	2
Transport and Handling	3
Atex Requirements	3
Slam-Shut Controller	4
Dimensions and Weights	5
Operation	6
Installation	7
Startup	8
Slam-Shut Controller Adjustment	9
Shutdown	9
Maintenance	9
Slam-Shut Controller Maintenance	10
Spare Parts	12
Troubleshooting	12
Parts Lists	13
Schematic Assemblies	14

INTRODUCTION

Scope of the Manual

This manual provides instructions for installation, startup, maintenance and spare parts ordering for the BM6X Series slam-shut valves. It also contains information for the OS/80X-R Series slam-shut controller.



Figure 1. BM6X Series Slam-Shut Valve

Product Description

The BM6X Series slam-shut valves are axial flow type and are used in natural gas reduction, distribution and transfer stations.

This product has been designed to be used with fuel gases of 1st and 2nd family according to EN 437, and with other non aggressive and non fuel gases. For any other gases, other than natural gas, please contact your local sales agent.

The standard gas pressure devices (safety shut-off devices - SSD slam-shut type) are those used in the assemblies dealt with into EN 12186 and EN 12279 and their use has to be under the provisions into ENs 12186 & 12279.

In the safety slam-shut valves manufactured by Emerson shall be used additional pressure accessories (e.g. controller or filters) manufactured and labeled by Emerson.

Emerson will not be responsible for any possible inefficiency due to installation of non Emerson production additional pressure accessories.

When pressure containing parts of safety slam-shut device (SSD) valve and controller have different maximum allowable pressures (PS), the SSD is the differential strength type.

BM6X Series

PED CATEGORIES AND FLUID GROUP

According to EN 14382, only in integral strength type and Class A configuration (when both over and under pressure protections are set up), this slam-shut valve can be classified like a safety accessory according to Pressure Equipment Directive PED 2014/68/UE.

The minimum PS between SSD valve and controller shall be the PS of the safety accessory to comply the provisions of EN 14382 about integral strength type.

This product in its Class A and integral strength configuration is a safety accessory for pressure equipment in the following Pressure Equipment Directive PED 2014/68/UE categories.

Table 1. PED Category for BM6X Series Slam-Shut Valves

PRODUCT SIZE	CATEGORY	FLUID GROUP
DN 80-100-150-200-250-300	IV	1

Possible built-in pressure accessories (e.g. controllers Types OS/80 and OS/80-X) conform to Pressure Equipment Directive PED 2014/68/UE Article 4 section 3 and were designed and manufactured in accordance with sound engineering practice (SEP).

Per Article 4 section 3, these "SEP" products must not bear the CE marking.

CHARACTERISTICS

Body Sizes and End Connection Styles

"Wafer" type body DN 80 - 100 - 150 - 200 - 250 - 300

Flanged body DN 150

ANSI 150 - 300 - 600

WARNING

Maximum Operating Inlet Pressure⁽¹⁾⁽²⁾

ANSI 150: 20 bar

ANSI 300: 50 bar

ANSI 600: 100 bar

Overpressure Set Range

0.03 to 80 bar

Underpressure Set Range

0.01 to 80 bar

Minimum/Maximum Allowable Temperature (TS)⁽¹⁾

See label.

- The pressure/temperature limits indicated in this instruction manual or any applicable standard or code limitation should not be exceeded.
- At average ambient temperature.

Functional Features

Accuracy Class AG : $\pm 1\%$

Response Time t_a : ≤ 1 second

Temperature

Standard Version: Working -10° to 60°C

Low Temperature Version: Working -20° to 60°C

Materials

Body: Steel

Butterfly disk: Cast iron or steel

Shaft: Steel

Spring: Stainless steel

Lip seal: FKM

O-ring: NBR nitrile rubber or FKM

LABELLING

The label contains the following information:

- Logo: Bologna Italy TARTARINI
- CE Marking: Notified body XXXX
- APPARECCHIO TIPO / DEVICE TYPE: Note 1
- MATRICOLO / ANNO SERIAL Nr. / YEAR: / Note 2
- REAZIONE FAIL SAFE MODE: FAIL OPEN FAIL CLOSE
- NORME ARMONIZ. HARMONIZED STD. EN
- CLASSE DI PERDITA LEAKAGE CLASS: Wds bar
- CLASSE FUNZIONALE FUNCTIONAL CLASS: Note 3, Cg, Wdso bar, Wdsu bar
- FLUIDO GRUPPO FLUID GROUP: 1, pmax bar, DN seat, DN sede, pdo bar
- TS: Note 4 °C, PS: Note 5 bar, PSD Bar, PT= 1.5 x PS bar

Figure 2. Label for BM6X Series Slam-Shut Valves

Note 1: See "Characteristics"

Note 2: Year of manufacture

Note 3: Class A or Class B
Only valves with overpressure and underpressure settings can be classified in Class A.

Note 4: Class 1: $-10^\circ/60^\circ\text{C}$
Class 2: $-20^\circ/60^\circ\text{C}$

Note 5: ANSI 150 PS: 20 bar
ANSI 300 PS: 50 bar
ANSI 600 PS: 100 bar

OVERPRESSURE PROTECTION

The recommended maximum allowable pressures are stamped on the slam-shut valve label.

Upstream overpressure protection shall be provided if the inlet pressure is greater than the maximum operating inlet pressure.

Downstream side pressure after slam-shut valve's intervention shall stay within the actual maximum operating set-up range to avoid anomalous back pressures that can damage the SSD's controller.

Downstream overpressure protection shall also be provided if the slam-shut valve outlet pressure can be greater than the PS of the pilot (differential strength type).

Slam-shut valve operation below the maximum pressure limitations does not preclude the possibility of damage from external sources or debris in the line.

The slam-shut valve should be inspected for damage after any intervention.

TRANSPORT AND HANDLING

Established transport and handling procedures shall be followed to avoid any damage on the pressure containing parts by shocks or anomalous stresses.

Eyebolts are designed just for handling of equipment weight.

Built-up sensing lines and pressure accessories (e.g. slam-shut controller) shall be protected by shocks or anomalous stresses.

ATEX REQUIREMENTS

Application of ATEX Product Directive:

Table 2. Overview

TYPE	CLASSIFICATION	ATEX ASSEMBLIES	ATEX LABELLING
Regulator/SSD	Non-electrical equipment	Not falling under the 2014/34/EU Directive	No
Regulator/SSD + electrical device	Non-electric equipment equipped with an electrical device falling under the scope of the ATEX Directive 2014/34/EU	Constitutes an assembly according to the 2014/34/EU Directive	CE Ex II 2 GT

WARNING

Carefully follow below instructions for the usage of "ATEX Assembly" in an explosive atmosphere.

A non-electrical equipment incorporating an electrical device (proximity, microswitch...) is an "ATEX Assembly", and in the scope of the ATEX Directive 2014/34/EU.

When such equipment(s) is used in a natural gas pressure control and/or measuring station in compliance with the following European standards: EN12186, EN12279 and EN 1776, can be installed in any type of classified zones according to the Directive 1999/92/EC dated 16 December 1999, in the following conditions:

- the equipment(s) / electrical circuit is connected to a suitable and certified intrinsically safe apparatus (suitable zener barrier)
- the equipment(s) / electrical circuit is used according to this instruction manual issued by the manufacturer and / or available on our website

ATEX Labelling

The nameplate will be installed on the ATEX assembly.

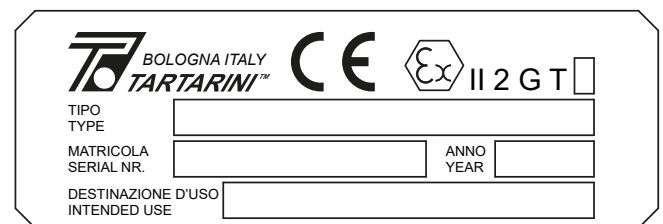

Figure 3. Label for ATEX Assembly

Where:

- Manufacturer:** Name and address and/or logo of the manufacturer
- CE** : Conformity marking to European Directive
- Type:** Description of the ATEX Assembly
- Serial Number and Year of Construction
- Ex** : Specific marking of explosion protection
- II**: Equipment group
- 2**: Equipment Category/level of protection 2 = suitable for zone 1
- G**: For gases, vapour or mists
- T**: Temperature Class (i.e.: T6 > 85 ... ≤ 100 °C)
- Intended Use:** Natural Gas infrastructures

BM6X Series

SLAM-SHUT CONTROLLER

The BM6X Series slam-shut valves are equipped with the Type OS/80X-R or OS/80X-R-PN slam-shut reinforced version controller. The controllers are supplied in different models according to set ranges required.

Table 3. Characteristics for Type OS/80X-R Spring Loaded Pneumatic Slam-Shut Controller

TYPE		SERVOMOTOR BODY RESISTANCE (bar)	OVERPRESSURE SET RANGE W_{do} (bar)		UNDERPRESSURE SET RANGE W_{du} (bar)		BODY MATERIAL
VALVE FLOW FROM LEFT TO RIGHT	VALVE FLOW FROM RIGHT TO LEFT		Min.	Max.	Min.	Max.	
OS/80X-BP-S-R	OS/80X-BP-R	5	0.03	2	0.01	0.6	Aluminum
OS/80X-BPA-D-S-R	OS/80X-BPA-D-R	20					
OS/80X-MPA-D-S-R	OS/80X-MPA-D-R	100	0.5	5	0.25	4	Steel
OS/80X-APA-D-S-R	OS/80X-APA-D-R		2	10	0.3	7	
OS/84X-S-R	OS/84X-R		5	41	4	16	Brass
OS/88X-S-R	OS/88X-R	18	80	8	70		

N.B.: 1/4" NPT female threaded connections

Table 4. Characteristics for Type OS/80X-R-PN Pneumatic Slam-Shut Controller with Type PRX Pilot

TYPE	SERVOMOTOR BODY RESISTANCE (bar)	OVERPRESSURE SET RANGE W_{do} (bar)		UNDERPRESSURE SET RANGE W_{du} (bar)		BODY MATERIAL
		Min.	Max.	Min.	Max.	
OS/80X-R-PN	100	0.5	40	0.5	40	Aluminum
OS/84X-R-PN	100	30	80	30	80	Brass

Type OS/80X-R-PN: Pressure range 0.5 to 40 bar

Appliance made of a Type OS/80X-APA-D-R set at about 0.4 bar and a variable number of Types PRX/182-PN pilots for overpressure and PRX/181-PN for underpressure, as many as necessary to control different points of the installation.

Type OS/84X-R-PN (Safety Accessory): Pressure range 30 to 80 bar

Appliance made of a Type OS/84X-R set at about 20 bar and a variable number of Types PRX-AP/182-PN pilots for overpressure and PRX-AP/181-PN for underpressure, as many as necessary to control different points of the installation.

N.B.: 1/4" NPT female threaded connections.

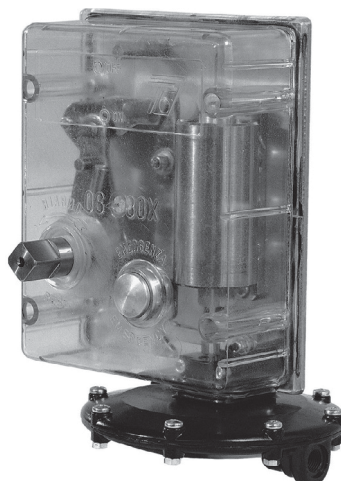

Figure 4. Type OS/80X-BP-R Slam-Shut Controller

DIMENSIONS AND WEIGHTS

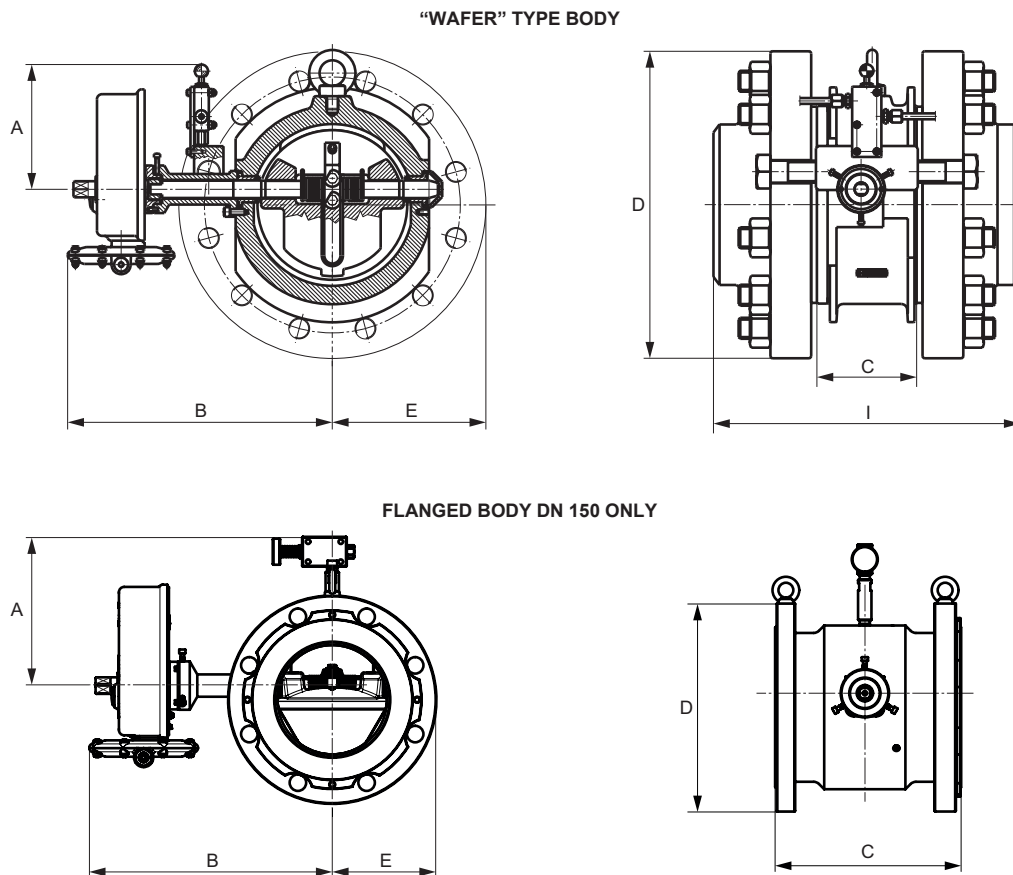

Figure 5. BM6X Series Dimensions

Table 5. BM6X Series Dimensions (mm)

TYPE	DN 80	DN 100	DN 150	DN 150 FLANGED BODY	DN 200	DN 250	DN 300
A	155	170	220	205	220	220	220
B	250	290	415	330	445	480	510
C	54	70	102	250	135	168	203
ANSI 150	D	190	230	279	280	343	406
	E	95	115	140	140	172	203
	I	197	227	284	-	342	375
ANSI 300	D	210	254	318	320	381	445
	E	105	127	159	160	191	223
	I	217	245	303	-	361	407
ANSI 600	D	210	274	357	356	419	508
	E	105	137	179	178	220	254
	I	235	264	354	-	419	490

N.B. The B dimensions are indicative and refer to the models with larger dimensions.

The threaded opening for the connection of the control line is 1/4" NPT female.

Table 6. BM6X Series Weights (kg)

TYPE	DN 80	DN 100	DN 150	DN 150 FLANGED BODY	DN 200	DN 250	DN 300
ANSI 150	10	13	22	54	38	71	111
ANSI 300			26	73	40	73	115
ANSI 600		15	33	95	45	77	121

OPERATION

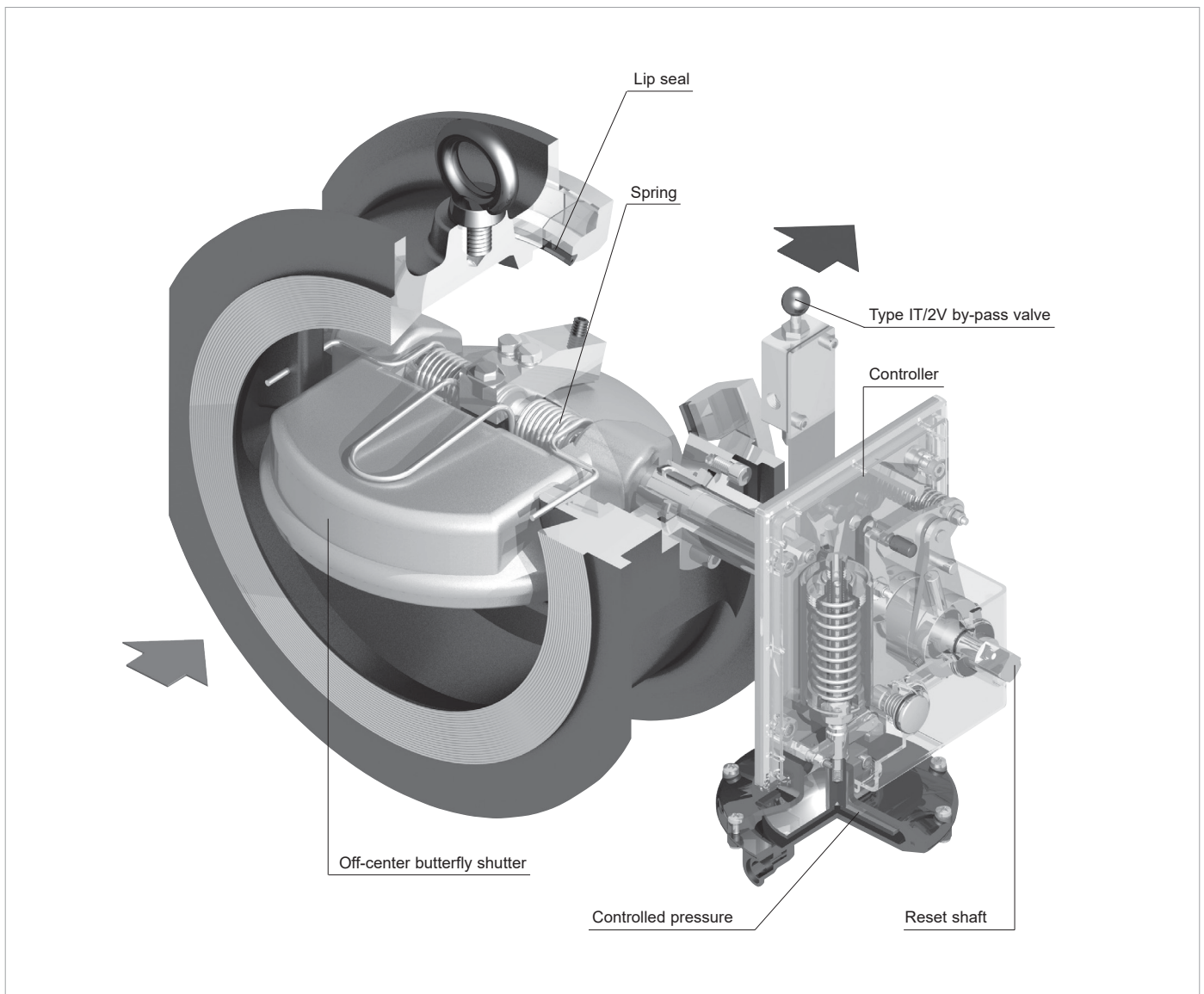

Figure 6. BM6X Series Operational Schematic

Slam-shut Valve

The BM6X Series slam-shut valve consists of a valve body, an pilot and a by-pass valve.

The valve body has an off-center butterfly disk that is mounted eccentrically on the reset shaft.

A lip seal ensures tightness.

The spring thrust, with the additional weight of the eccentric off-center butterfly disk, ensures punctual and safe closure under any working conditions.

In addition, the compression of the seal, which is determined by the pressure, ensures perfect tightness.

The slam-shut valve can only be opened if the upstream and downstream pressures are equal.

The Type IT/2V by-pass valve with automatic return makes it possible to balance these pressures. The valve can only be opened manually by rotating the pilot reset shaft.

When the controlled pressure lies within the set levels for the pilot, the latter remains set and prevents rotation of the shaft while keeping the butterfly disk open.

When said pressure changes beyond the set levels, the butterfly disk moves to the closure position.

INSTALLATION

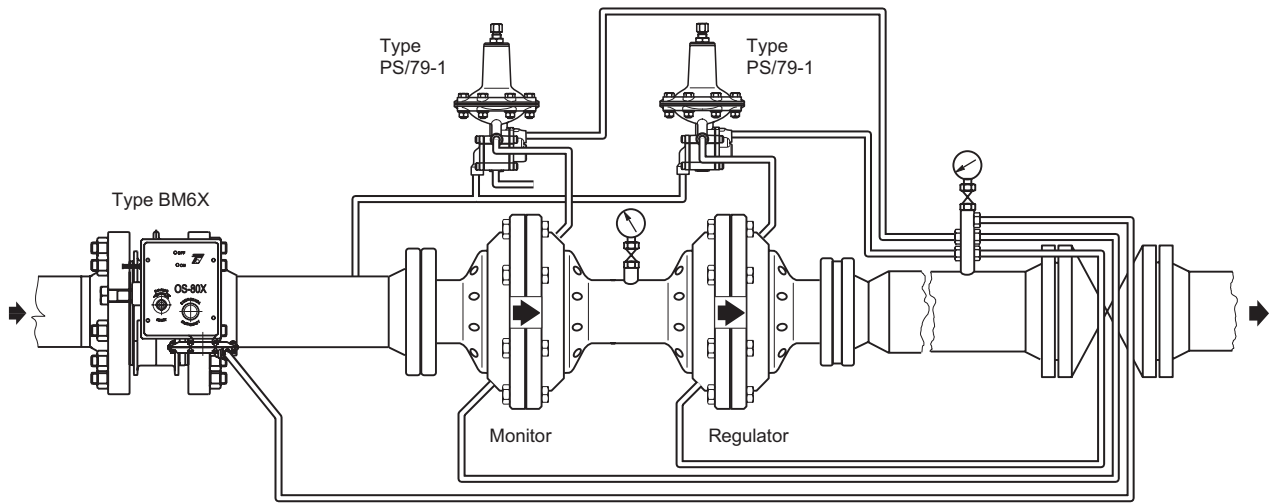

SLAM-SHUT VALVE WITH TYPE OS/80X-R CONTROLLER - INSTALLATION IN A LOW PRESSURE REGULATING LINE

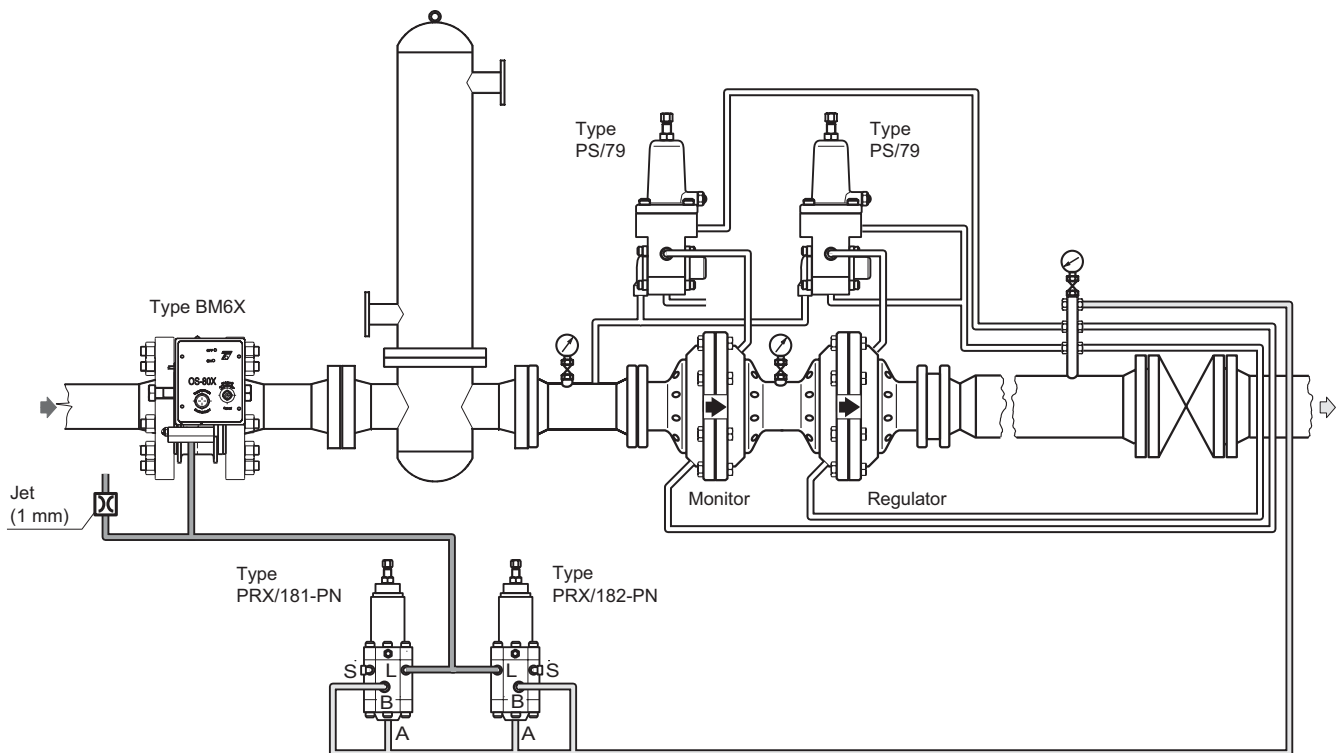

SLAM-SHUT VALVE WITH TYPE OS/80X-R-PN CONTROLLER - OVERPRESSURE AND UNDERPRESSURE CONTROL DOWNSTREAM OF REGULATORS

LEGEND:

① DOWNSTREAM OR TO A SAFE AREA

NOTE: RECOMMENDED PIPING IS STAINLESS STEEL WITH 10 mm DIAMETER.

Figure 7. BM6X Series Connection/Installation Schematics

INSTALLATION (CONTINUED)

- Ensure that the data found on the slam-shut valve label are compatible with usage requirements.
- Make sure that slam-shut controller is installed up-right.
- Ensure that the slam-shut valve is mounted in accordance with the direction of flow indicated by the arrow.
- Make the connections as shown in Figure 7. Make the connection of the pressure control pipe, taking it off a straight section of the downstream pipe, if possible far from narrow sections, curves, or branches, to avoid variations in the release values of slam-shut device caused by turbulence.

WARNING

Only qualified personnel should install or service a slam-shut valve.

Slam-shut valve should be installed, operated, and maintained in accordance with international and applicable codes and regulations.

If the slam-shut valve vents fluid or a leak develops in the system, it indicates that servicing is required.

Failure to take the slam-shut valve out of service immediately may create a hazardous condition.

Personal injury, equipment damage, or leakage due to escaping fluid or bursting of pressure-containing parts may result if this slam-shut valve is overpressured or is installed where service conditions could exceed the limits given in the “Characteristics” section, or where conditions exceed any ratings of the adjacent piping or piping connections.

To avoid such injury or damage, provide pressure-relieving or pressure-limiting devices (as required by the appropriate code, regulation, or standard) to prevent service conditions from exceeding limits.

Additionally, physical damage to the slam-shut valve could result in personal injury and property damage due to escaping fluid.

To avoid such injury and damage, install the slam-shut valve in a safe location.

Before installation, check shall be done if service conditions are consistent with use limitations and if its slam-shut device set-up is in accordance with service conditions of protected equipment.

All means for venting have to be provided in the assemblies where the pressure equipment are installed (ENs 12186 & 12279).

All means for draining have to be provided in the equipment installed before the slam-shut valve (ENs 12186 & 12279).

Further the ENs 12186 & 12279, where this product is used:

- Provide the cathodic protection and electrical isolation to avoid any corrosion
- In accordance with relevant clauses of aforesaid standards, the gas shall be cleaned by proper filters/separators/scrubbers to avoid any technical & reasonable hazard of erosion or abrasion for pressure containing parts

Slam-shut valve shall be installed in non-seismic area and hasn't to undergo fire and thunderbolt action.

Clean out all pipelines before installation of the slam-shut valve and check to be sure the slam-shut valve has not been damaged or has collected foreign material during shipping.

Use suitable line gaskets and approved piping and bolting practices.

Installation must to be done avoiding anomalous stresses on the body and using suitable joint means (bolts, flanges, ...) according equipment dimensions and service conditions.

Install the slam-shut valve in any position desired, unless otherwise specified, but be sure flow through the body is in the direction indicated by the arrow on the body.

User has to check and carry out any protection suitable for assembly's specific environment.

For outdoor installations, the slam-shut valve should be located away from vehicular traffic and positioned so that water, ice, and other foreign materials cannot enter into the pilot mechanism.

Avoid placing the slam-shut valve beneath eaves or downspouts, and be sure it is above the probable snow level.

STARTUP

The built-in slam-shut controller is factory set at approximately the midpoint of the spring range or the pressure requested, so an initial adjustment may be required to obtain desired results.

- a. Slightly and very slowly open inlet valve upstream of the Type BM6X.
- b. Open by-pass valve (key 18) by pressing knob (P). Keep knob pressed until downstream pressure increases so as to permit valve disc to become balanced, after which release knob.
- c. Using the appropriate lever, rotate shaft (B) in the direction shown by the arrow stamped on the controller cover so as to permit slam shut valve to open. Keep the valve open manually.

⚠ CAUTION

In case you note an excessive resistance in the opening operation, possible ΔP upstream/downstream can be the root cause: repeat above step b to balance upstream and downstream pressures.

- d. Slightly open outlet valve and wait for downstream pressure to stabilize.
- e. Act on shaft (B) several times to make sure that actuator remains properly latched.
- f. First slowly open the valve upstream of the Type BM6X completely, then slowly open the valve downstream of the regulator.

SLAM-SHUT CONTROLLER ADJUSTMENT

To change the slam-shut controller setpoints (overpressure and/or underpressure), remove the spring closing cap of the controller and turn the adjusting screws clockwise to increase outlet pressure or counterclockwise to decrease pressure.

Monitor outlet pressure with a test gauge during the adjustment.

SHUTDOWN

⚠ WARNING

To avoid personal injury resulting from sudden release of pressure, isolate the slam-shut valve from all pressure before attempting disassembly and release trapped pressure from the equipment and pressure line. In case of disassembly of main pressure retaining parts for checks and maintenance procedures, external and internal tightness tests have to be done according to applicable codes.

MAINTENANCE (SEE FIGURES 9, 10 AND 11)

⚠ WARNING

All maintenance procedures must be carried out only by qualified personnel.

If necessary, contact our technical support representatives or our authorized dealers.

The valve and its pressure accessories are subject to normal wear and must be inspected periodically and replaced if necessary.

The frequency of inspection/checks and replacement depends upon the severity of service conditions and according to applicable National or Industry codes, standards and regulations/recommendations.

In accordance with applicable National or Industry codes, standards and regulations/recommendations, all hazards covered by specific tests after final assembling before applying the CE marking, shall be covered also after every subsequent reassembly at installation site, in order to ensure that the equipment will be safe throughout its intended life.

Before proceeding with any maintenance work, shutoff the gas upstream and downstream from the valve, also ensure that there is no gas under pressure inside the body by loosening the upstream and downstream connections.

Upon completion, check for leaks using suds.

General Maintenance

- a. Cause the actuator to trigger, remove the impulse line (A) and take off the slam shut valve from the line.
- b. Loosen screws (key 13) and slide the controller out.
- c. Remove gasket retaining ring (key 26) and replace gasket (key 25).

Only for DN 150/200/250/300: Loosen screw (key 40), remove gasket retaining ring (key 26) and replace gasket (key 25).
- d. Loosen screws (key 10) and remove hub (key 14).
- e. Loosen plug (key 6). Loosen screws (key 21), remove washers (key 22), and shaft lever (key 29).
- f. Rotate the shaft (key 2) for 180° and take off the bracket (key 27). Dismount the shaft from the Type OS/80X-R side.

⚠ CAUTION

The valve shutter (key 24) is free, hold it in order to prevent it from falling.

- g. With the given special wrench dismount the guide bushes (key 8), and replace O-rings (keys 3 and 5).
- h. Check all moving parts, paying special attention to nickel plated surfaces. Replace any that are worn or damaged.
- i. Remove by-pass valve (key 18) and carry out maintenance.

Reassembly

Lubricate all seals with Molykote 55 M or equivalent, being very careful not to damage them when reassembling.

Reassemble the parts by reversing the above steps.

As you proceed, make sure that parts move freely and without friction.

BM6X Series

In addition:

- Complete reassembly and make sure to tighten all screws uniformly.
- During the shaft insertion inside the shutter it's necessary to push spring (key 9). Make sure not to damage the shaft surface, near the guide bushes.
- When reassembling lever shaft (key 29) replace the washers (key 22) and apply glue Loxeal 55-03, or equivalent, to the screws (key 21).

- After the reassembly completion, check the proper functioning of all parts. Check the valve with soapy water, making sure there are no leaks.
- Remount valve on the line and reestablish all connections.

SLAM-SHUT CONTROLLER MAINTENANCE (SEE FIGURE 12)

Installation

- Install the slam-shut controller in a covered area and protect it against weather agents.
- Check that data on the plate are compatible with actual working conditions.
- Make sure slam-shut controller is installed upright, i.e. screw (key 49) on top.

⚠ WARNING

Check the dimension "C" value indicated on Table 6. If is necessary adjust, through the appropriate screw (key 20), the shutter position.

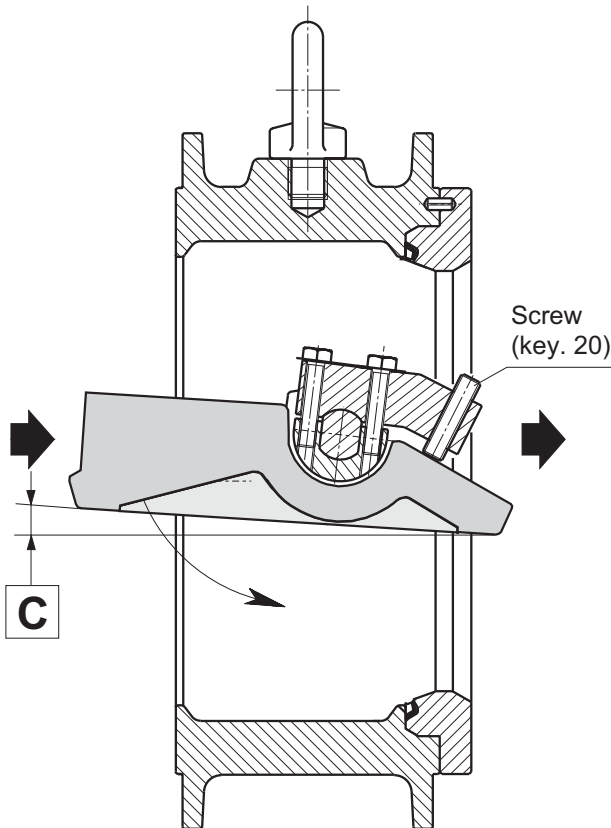

Figure 8. Type BM6X Shutter Position

Table 7. Type BM6X Shutter Position Dimensions

TYPE	C
BM6X/80	Min. 1 mm - Max 3 mm
BM6X/100	Min. 1 mm - Max 5 mm
BM6X/150	Min. 3 mm - Max 8 mm
BM6X/200	Min. 5 mm - Max 10 mm
BM6X/250	Min. 6 mm - Max 11 mm
BM6X/300	Min. 8 mm - Max 13 mm

⚠ CAUTION

Mounting in any other way will jeopardize controller's performance.

- Carry out the connection of gas outlet (A). It must be derived from the pressure control piping, in a straight tract, possibly far away from restrictions, curves or derivations, in order to avoid turbulence that can alter the trip pressure setpoints.

Startup

- Using lever, activate slam-shut by turning reset stem (key 6) in the direction shown by the arrow.
- Wait until the pressure being controlled stabilizes and then slowly release lever.
- Now repeat this procedure, make sure that levers keep slam-shut controller properly set and that lever (key 33) is in horizontal position.

Periodical Checks

It is recommended that slam-shut controller be efficiency checked periodically.

Cut-off Test

- Cut-off the circuit by means of inlet and outlet valves and disconnect the pressure control pipe (A). The slam-shut controller should cut-off at minimum pressure (only if so set).

- b. Through the pressure control connection, use a small pump or other appropriate means, to raise the pressure to normal operating level. Reset slam-shut controller after cut-off in step a.
- c. Simulate pressure increase until maximum pressure cutoff value is reached.
- d. Connect the pressure control slam-shut controller (A) and set the circuit back to operating conditions by following the instructions described in the Startup section.

Valve-seal Check

- a. Slowly close the valve located downstream.
- b. Press the "EMERGENCY" button. This will cause the immediate closing of slam-shut controller.
- c. Loosen a connector in the downstream line of the slam-shut valve or of the regulator. Check the connector with soap and water, making sure there are no leaks; make any necessary repairs otherwise.

Maintenance

Routine slam-shut controller maintenance entails simply periodic checking of the diaphragm on the Type OS/80X-R (the piston lip seal on the Type OS/84X-R) and the movement of the levers, i.e. they should move freely with a minimum of friction. If necessary, lubricate pins with Molykote 55 M or equivalent.

WARNING

For a successful job it is indispensable to use qualified personnel, possibly calling on our Technical Support Representatives.

Before starting maintenance, disconnect impulse connection (A) to make sure there is no gas under pressure in the slam-shut controller. When maintenance operations are finished check the tightness with suds.

Replacing Diaphragm (Type OS/80X-R only)

- a. Remove screws (key 27) and cover (key 61).
- b. Replace diaphragm (key 62).
- c. To remount diaphragm, coat it with grease, set it in place around the edge of cover (key 61) and evenly tighten screws (key 27) to ensure proper sealing.

Replacing O-ring (Types OS/84X-R and OS/88X-R only)

- a. Remove plug (key 61) and extract piston (key 68) from body (key 60).

- b. Replace O-ring (key 67) and lip seal (key 66).
- c. Reassemble by reversing the above procedures.

General Maintenance

- a. Remove screws (key 40) and casing (key 47).
- b. Remove dowels (key 12) and bushing (key 13).
- c. Slide off stem (key 6), lever assembly (keys 17 and 2), rollers (key 10) and shim ring (key 15). Wash parts, replace any if worn.
- d. Remove nuts (key 18), levers (keys 20 and 36) and springs (keys 37 and 21).
- e. Remove nut (key 30), screw (key 29) and lever (key 33).
- f. Remove minimum adjusting screw (key 49), maximum adjusting nut (key 50) and springs (keys 53 and 54).
- g. Remove cover (key 61) on Type OS/80X-R, or plug on Types OS/84X-R and OS/88X-R, and proceed as directed in replacing diaphragm/O-ring section.
- h. Remove nut (key 70) and locknut (key 69), then slide off stem unit (key 57).
- i. Loosen screw (key 3), unscrew nut (key 9), remove rollers holder (key 5) and check seals (keys 4 and 8) for wear.
- J. Clean all parts with petrol, replace any if worn.

Reassembly

Reassemble all parts by reversing the steps in the general maintenance section.

As you proceed, make sure all parts move freely without friction. If necessary, lubricate them with Molykote 55 M or equivalent.

Make sure to:

- a. Narrow the gap between nuts (keys 30 and 18) so that levers (keys 33, 36, and 20) have minimum play yet move freely without friction.
- b. Before mounting minimum spring (key 54), register position of lever (key 33) by means of nut (key 70), locking it into place with locknut (key 69).

CAUTION

The lever (key 33) is in proper position when it is exactly horizontal and in the center of the groove of lever (key 36).

BM6X Series

- c. Now remount lever assembly (keys 17 and 2), rollers (key 10), keeping them in their seat with grease, and stem (key 6), which is to be turned so the rollers enter their seats. The stem and lever assembly should now be tightly fitted together.
- d. Remount bushing (key 13), make sure that the dowels are firmly set in the grooves of the stem (key 6).
- e. Repeatedly check if pilot resets properly and, lastly, remount minimum spring (key 54).
- f. Always check controller setting.

Minimum and Maximum Setting

- a. Make sure that the lever (key 33) is in horizontal position when slam-shut controller is reset. If necessary, use nut and locknut (keys 69 and 70) to adjust (see step b, Reassembly section).
- b. Use maximum adjusting nut (key 50) to completely load maximum pressure spring (key 53). Loosen minimum adjusting screw (key 49) to completely relieve minimum pressure spring (key 54).
- c. Disconnect pressure control pipe (A).
- d. Through the pressure control connection, use a small pump or other appropriate means to raise the pressure to normal operating level.
- e. Reset slam-shut controller and reduce the pressure until it reaches minimum cutoff level.

- f. Use minimum adjusting screw (key 49) to load spring (key 54) slowly until pilot is triggered.
- g. Repeat procedures (d) and (e) above, making any necessary adjustment in the setting.
- h. Bring pressure back to normal values.
- i. Reset controller and raise the pressure until it reaches maximum cutoff level.
- j. Using maximum adjusting nut (key 50), slowly unload spring (key 53) until cut-off point is reached.
- k. Repeat procedures (h) and (i) above, making any adjustment necessary in the setting.

⚠ CAUTION

Whenever minimum or maximum pressure setting is not required, omit corresponding steps.

SPARE PARTS

Spare parts storage shall be done by proper procedures according to national standard/rules to avoid over aging or any damage.

TROUBLESHOOTING

Table 8. Troubleshooting for BM6X Series Slam-Shut Valve

SYMPTOMS	CAUSE	ACTIONS
Slam-shut device does not remain set	The actuator impulse intake (A) is not connected properly	Check connections (A)
	Downstream pressure coincides with the maximum or minimum slam-shut settings	Check slam-shut settings
	Diaphragm (key 62) is damaged (Lip seal (key 66) on Types OS/84X-R and OS/88X-R)	Replace the diaphragm
Sleeve does not seal properly	Worn seal gaskets	Check gaskets
	Dirt deposit on sleeve	Check sleeve
	Shaft (key 2) damaged	Check shaft

PARTS LISTS

BM6X Series Slam-Shut Valve (See Figures 9, 10 and 11)

Key	Description
1	Eyebolt
2	Shaft
3*	O-ring
4*	Antiextrusion ring
5*	O-ring
6	Plug
7	Bush
8	Guide bush
9	Spring
10	Screw
11	Needle
12	Controller
13	Special screw
14	Hub
15	Screw
16	Screw
17	Bracket
18	IT/2V by-pass valve
19	Self locking nut
20	Screw
21	Screw
22*	Washer
23	Body
24	Shutter
25*	Gasket
26	Ring
27	Shaft bracket
28	Pin
29	Shaft lever
30	Bracket
31	Screw
32	Label
33	Rivet
34	Spacer
35	Stud
37	Lever unit
38	Body ring
39	Ring
40	Screw
41	Stud bolt
42	Spring plug
43	Plug
44*	O-ring
45*	O-ring

OS/80X-R Series Slam-Shut Controller (See Figure 12)

Key	Description
1	Plate
2	Releasing bushing
3	Screw
4*	Gasket
5	Rollers holder
6	Stem
7	Roller
8*	O-ring
9	Reloading nut
10	Roller
11	Roller
12	Dowels
13	Reloading bushing
14*	O-ring
15	Ring
17	Reloading lever unit
18	Self-locking nut
19	Washer
20	Return lever
21	Spring
22	Fulcrum
24	Label
26	Nut
27	Screw
28	Reloading pin
29	Screw
30	Self-locking nut
31	Washer
32	Plate fulcrum
33	Lever
34	Screw
35	Cone
36	Releasing lever
37	Spring
38	Plug
39	Locking pin
40	Screw
41	Indicator pin
42	On-Off indicator
43	Button
44*	O-ring
45	Spring
46	Gasket
47	Casing

Key	Description
48	Screw
49	Minimum pressure adjusting screw
50	Maximum pressure adjusting nut
51	Pipe assembly
52	Washer
53	Spring
54	Spring
55	Lower spring holder unit
56	Elastic ring
57	Stem unit
58	Spring
59	Plate holding stem unit
60	Top cover (body for Types OS/84X-R and OS/88X-R)
61	Lower cover (plug for Types OS/84X-R and OS/88X-R)
62*	Diaphragm
63	Screw
64	Block
65*	O-ring
66*	Lip seal
67*	O-ring
68	Piston
69	Locknut
70	Nut
71	Microswitch
73*	Gasket (only for Types BP, BPA-D and MPA-D)
74	Filter

Rubber parts marked with (*) are supplied in the "spare parts kit", recommended as stock.

To order the kit it is necessary to communicate to us the type of the slam-shut valve or slam-shut controller and its serial number.

SCHEMATIC ASSEMBLIES

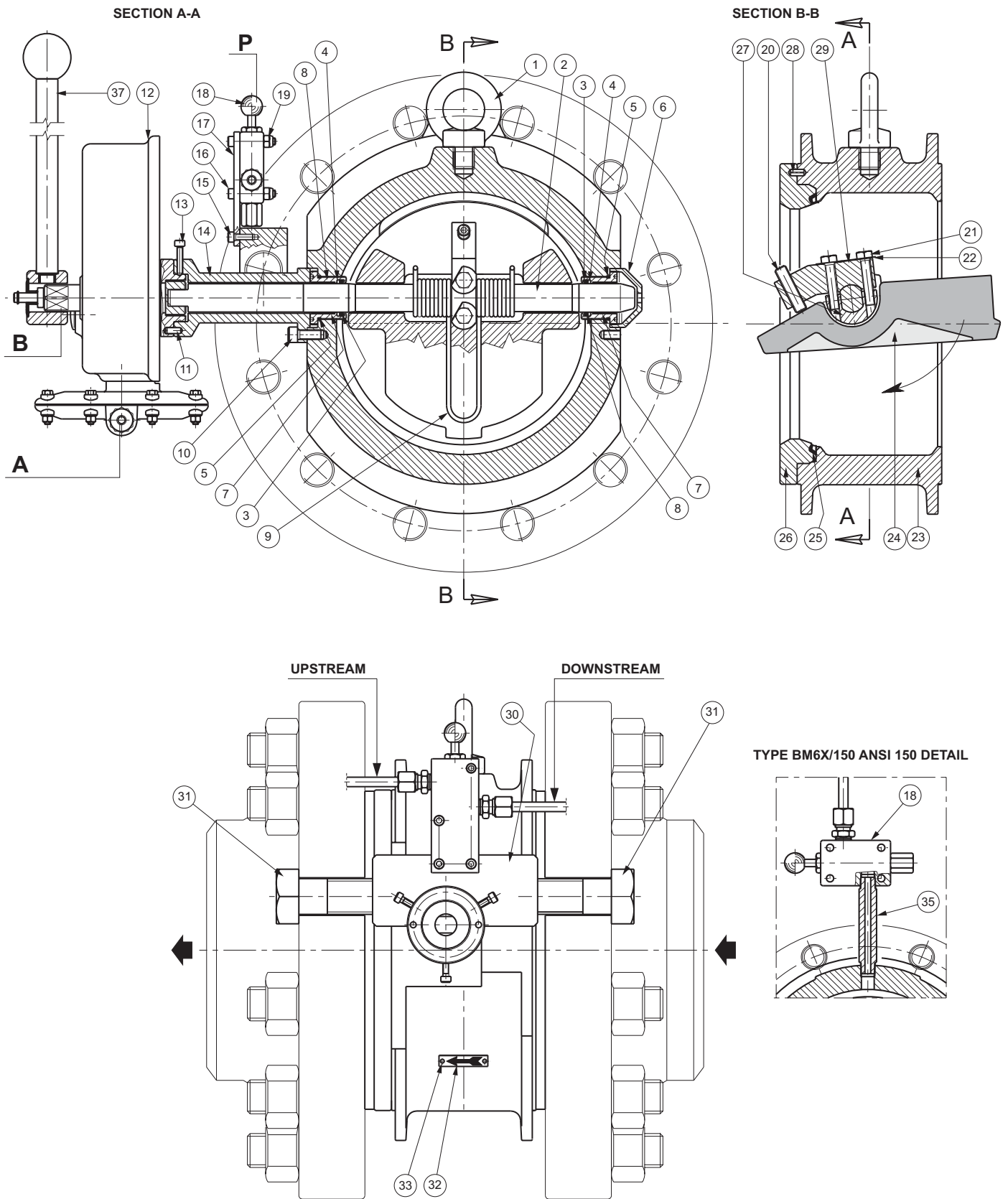

Figure 9. BM6X Series Slam-Shut Valve DN 80/100/150 Casting Version

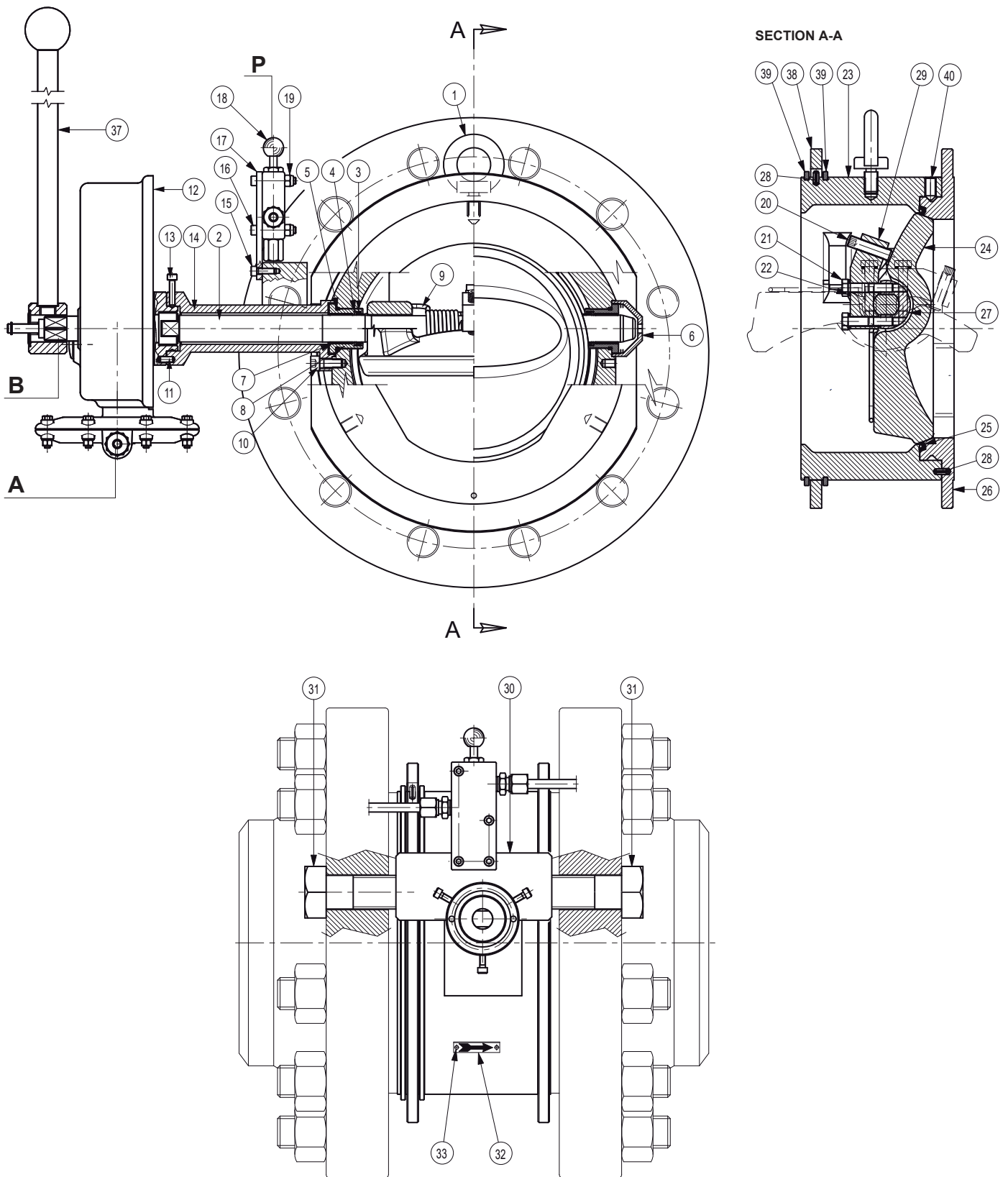
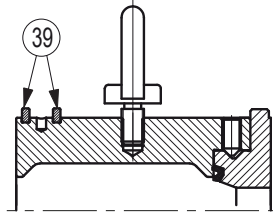
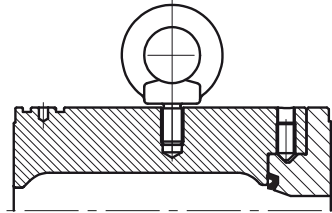

Figure 10. BM6X Series Slam-Shut Valve DN 150/200/250/300 Machined Version

ANSI 150 DETAIL



TYPE BM6X/200



TYPE BM6X/250/300

TYPE BM6X/200 ANSI 150 DETAIL

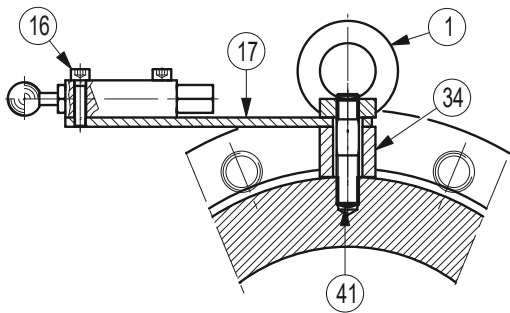

TYPE BM6X/250/300 DETAIL

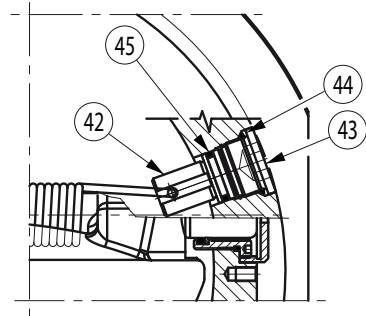

TYPE BM6X/300 DETAIL

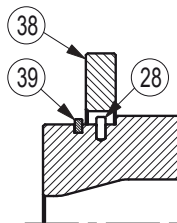

Figure 10. BM6X Series Slam-Shut Valve DN 150/200/250/300 Machined Version (continued)

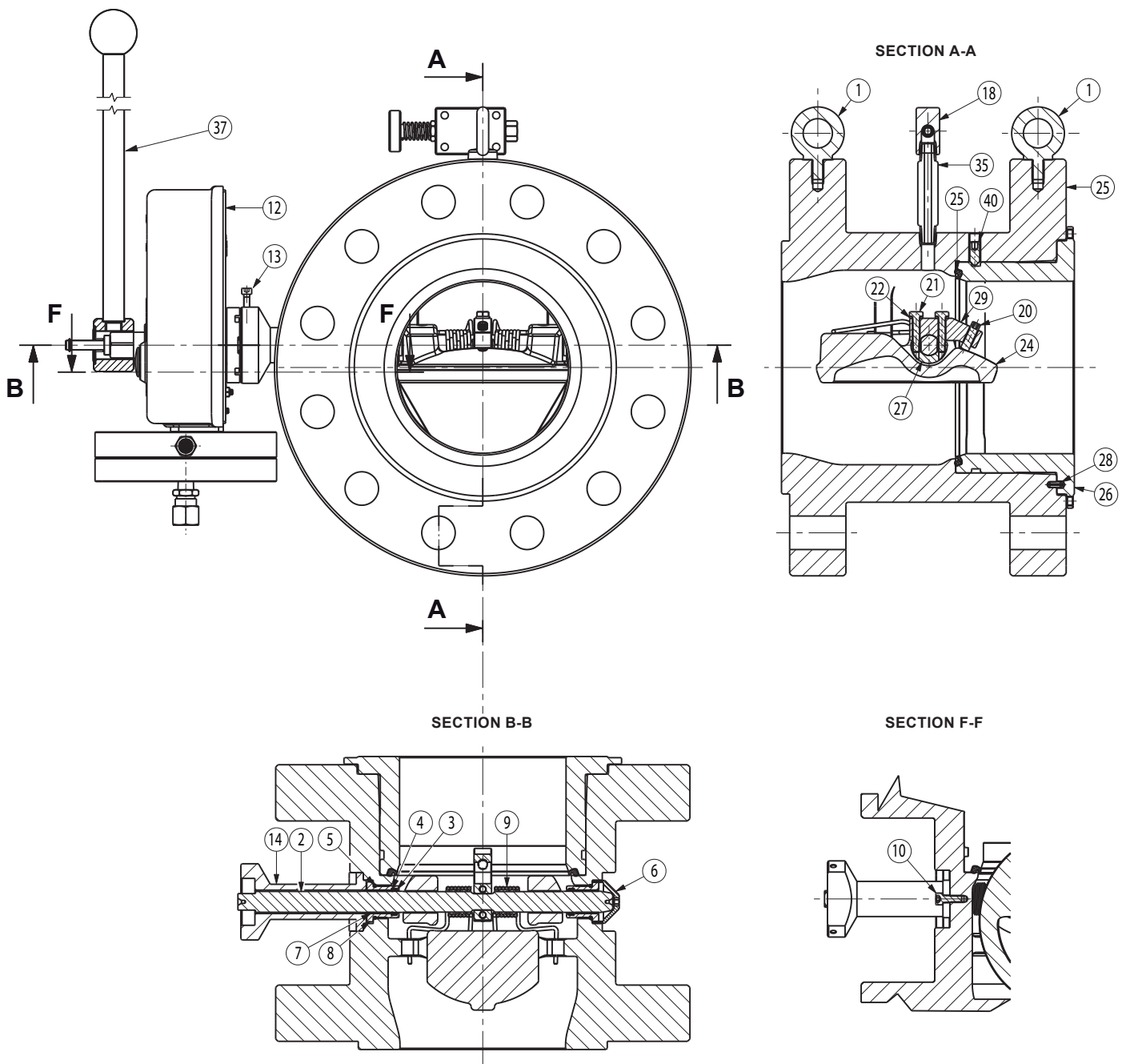
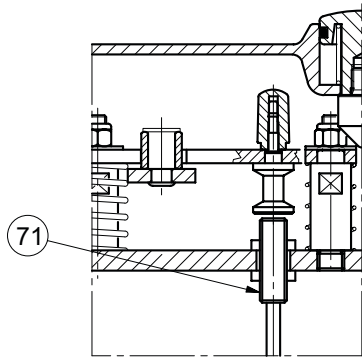
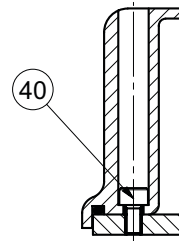

Figure 11. Series Slam-Shut Valve DN 150 Flanged Body Version

BM6X Series



DETAIL OF TYPE OS/80X-R WITH MICROSWITCH



SECTION D-D

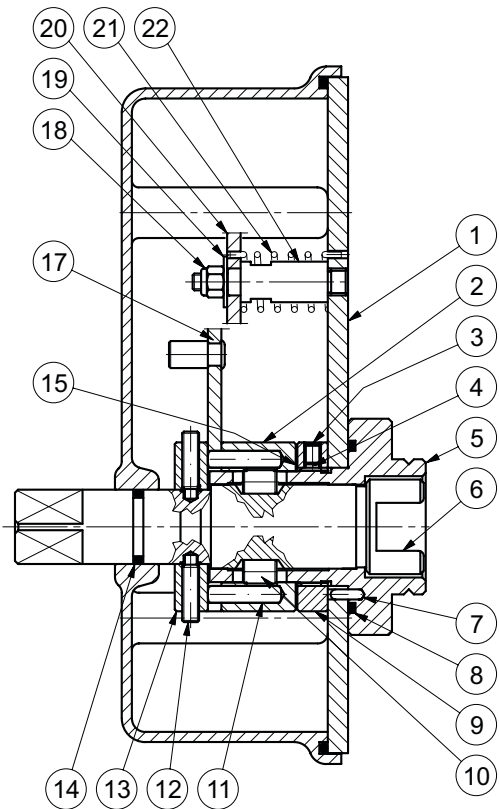

SECTION C-C

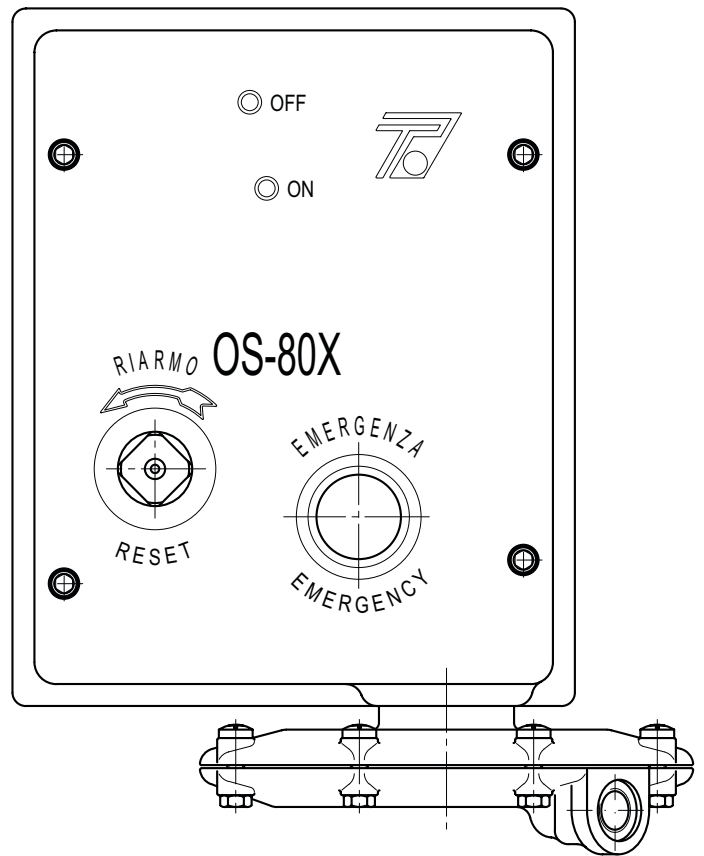
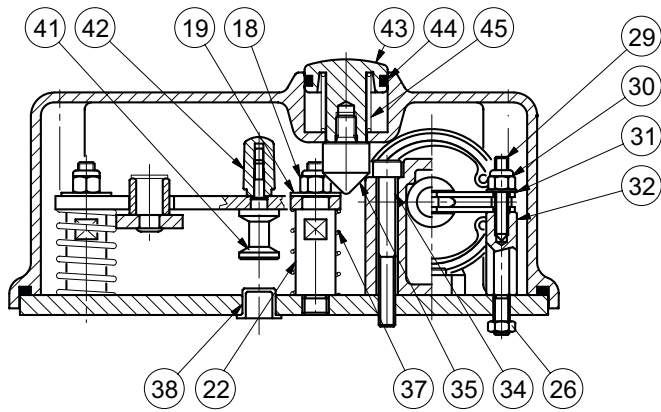
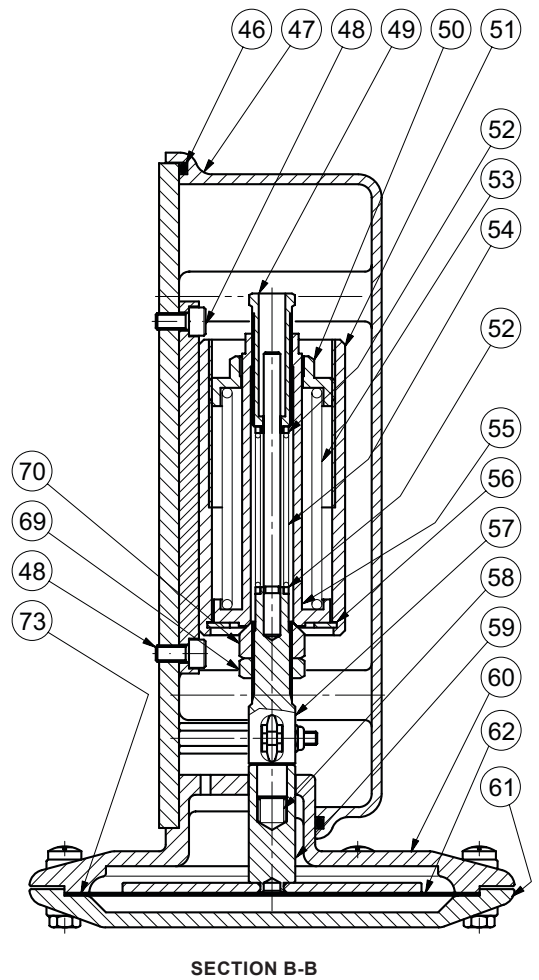
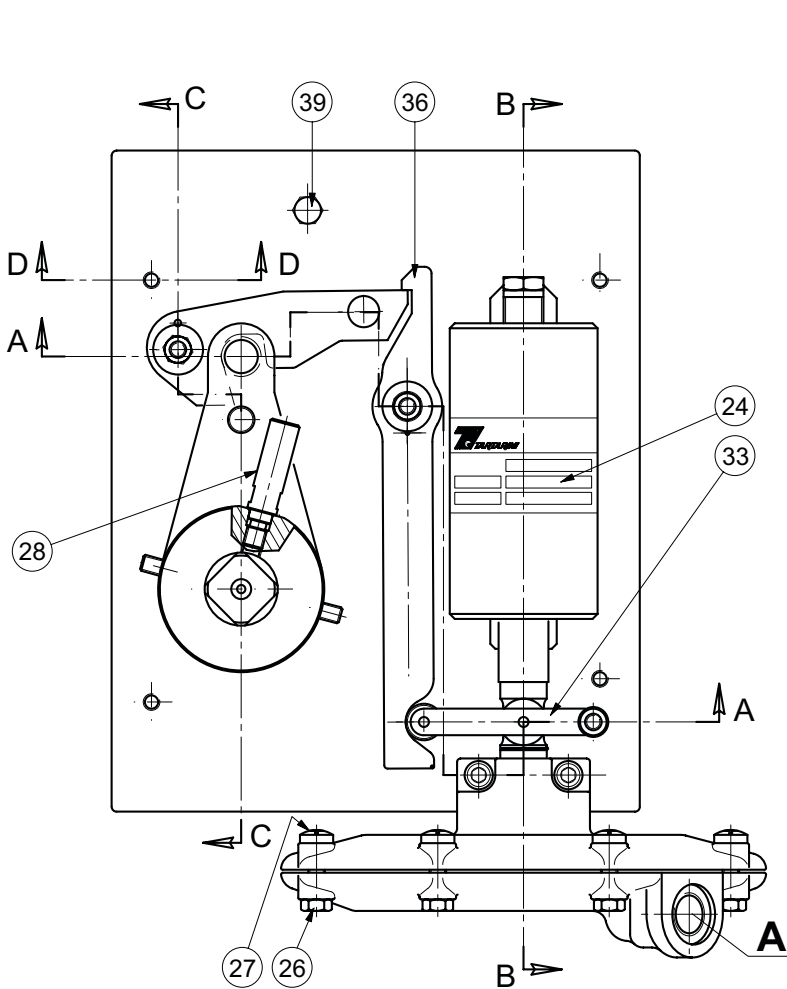

Figure 12. Type OS/80X-R Slam-Shut Controller Reinforced Version



SECTION A-A



SECTION B-B

Figure 12. OS/80X-R Series Slam-Shut Controller Reinforced Version (continued)

BM6X Series

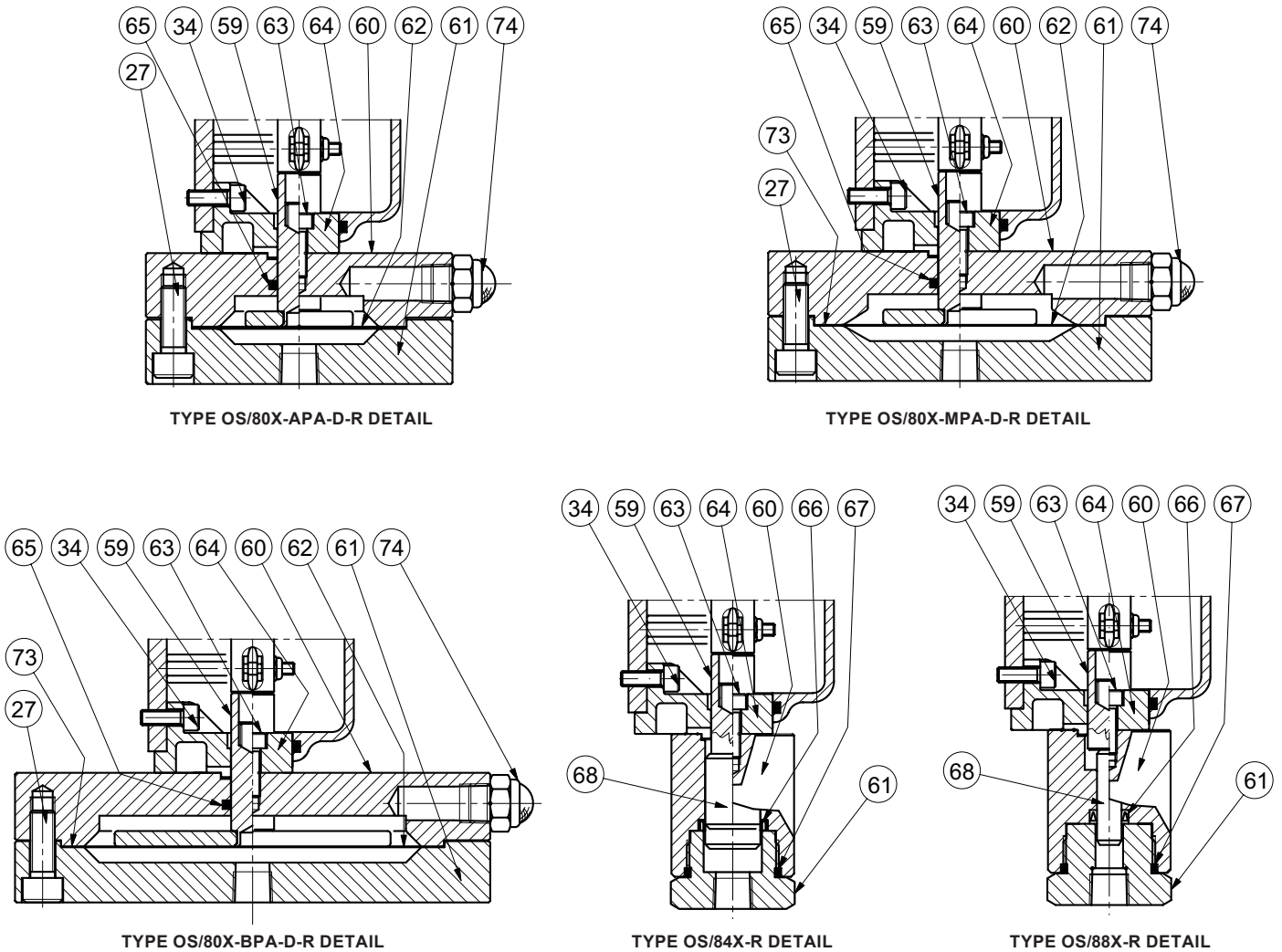

Figure 12. OS/80X-R Series Slam-Shut Controller Reinforced Version (continued)

✉ Webadmin.Regulators@emerson.com

🔍 Tartarini-NaturalGas.com

📘 Facebook.com/EmersonAutomationSolutions

🌐 LinkedIn.com/company/emerson-automation-solutions

🐦 Twitter.com/emr_automation

Emerson Automation Solutions

Americas

McKinney, Texas 75070 USA
T +1 800 558 5853
+1 972 548 3574

Asia Pacific

Singapore 128461, Singapore
T +65 6777 8211

Europe

Bologna 40013, Italy
T +39 051 419 0611

Middle East and Africa

Dubai, United Arab Emirates
T +971 4 811 8100

O.M.T. Officina Meccanica Tartarini S.R.L., Via P. Fabbri 1, I-40013 Castel Maggiore (Bologna), Italy
R.E.A 184221 BO Cod. Fisc. 00623720372 Part. IVA 00519501209 N° IVA CEE IT 00519501209,
Cap. Soc. 1.548 000 Euro i.v. R.I. 00623720372 - M BO 020330

D103664X012 © 2018, 2020 Emerson Process Management Regulator Technologies, Inc. All rights reserved. 05/2020.

The Emerson logo is a trademark and service mark of Emerson Electric Co. All other marks are the property of their prospective owners. Tartarini™ is a mark of O.M.T. Officina Meccanica Tartarini s.r.l., a business of Emerson Automation Solutions.

The contents of this publication are presented for information purposes only, and while effort has been made to ensure their accuracy, they are not to be construed as warranties or guarantees, express or implied, regarding the products or services described herein or their use or applicability. All sales are governed by our terms and conditions, which are available on request. We reserve the right to modify or improve the designs or specifications of our products at any time without notice.

Emerson Process Management Regulator Technologies, Inc does not assume responsibility for the selection, use or maintenance of any product. Responsibility for proper selection, use and maintenance of any Emerson Process Management Regulator Technologies, Inc. product remains solely with the purchaser.

