

May 2023

Type OSE Slam-Shut Valve

Features and Benefits

- **Overpressure and Underpressure Protection**— Type OSE can be equipped for **OverPressure ShutOff (OPSO)**, **UnderPressure ShutOff (UPS0)**, **Overpressure, UnderPressure ShutOff (OPSO/UPS0)** and **Dual OverPressure ShutOff (OSPO/OPSO)**.
- **High Shock and Vibration Resistance**— Type OSE incorporates a two-stage tripping mechanism that significantly reduces nuisance tripping caused by vibrations or inlet pressure variations commonly experienced by other shut-off valves.
- **NPS 1 through 10 / DN 25 through 250 Body Sizes**
- **High Accuracy**— Maintains up to $\pm 1\%$ accuracy regardless of inlet pressure, flow rate and the size of the slam-shut.
- **Easy In-Line Maintenance**—Top entry design reduces maintenance time and manpower requirements; parts can be inspected and replaced without removing the body from the line.
- **Water Tight**—Type OSE is water tight to 10 ft / 3.0 m.
- **Positive Shutoff**—After closing, the slam-shut valve stays closed until the system is shut down and the valve is manually reset. An O-ring on the valve plug seal provides tight shutoff.
- **Remote Alarm Capability**—A limit switch is available that detects when the Type OSE slam-shut valve is tripped.
- **Remote Shutoff Capability**—Remote Tripping can be achieved by combining the Type OSE with a 3-way solenoid valve. Manual tripping is also possible using the Manual Push Button Trigger Switch option.

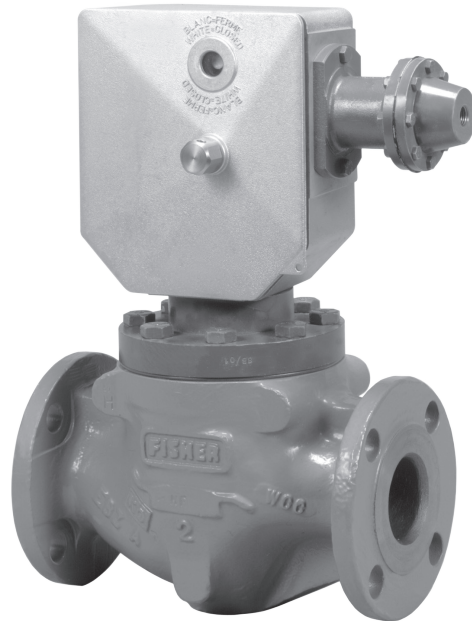

P2223

Figure 1. Type OSE Slam-Shut Valve

Introduction

The purpose of the Type OSE slam-shut device is to totally and rapidly cut the flow of gas when the inlet and/or outlet pressure in the system either exceed or drop below setpoints. Type OSE consists of a valve, a mechanism box (BM1 or BM2) and either one or two manometric sensing devices (Type BMS1 or BMS2).

Type OSE slam-shut valve can be used for all pressure ranges from 4.0 in. w.c. to 1470 psig / 10 mbar to 101 bar by simply replacing the manometric sensing device. In addition, Type OSE can be configured for overpressure shutoff (OPSO), underpressure shutoff (UPS0), overpressure and underpressure shutoff (OPSO/UPS0), dual overpressure shutoff (OSPO/OPSO), manual shutoff or remote shutoff.

Type OSE

Specifications

This section lists the specifications for the Type OSE slam-shut valve. Factory specifications are stamped on the nameplate fastened on the valve at the factory.

Body Sizes and End Connection Styles

WCC Steel

1 and 2 NPT; NPS 1, 2, 3, 4 and 6 / DN 25, 50, 80, 100 and 150; CL150 RF, CL300 RF or CL600 RF

LCC Steel

NPS 8 and 10 / DN 200 and 250; CL150 RF, CL300 RF or CL600 RF

Cast iron

1 and 2 NPT; NPS 1, 2, 3, 4 and 6 / DN 25, 50, 80, 100 and 150; CL125 FF

Maximum Inlet Pressure⁽¹⁾

NPT Cast iron: 400 psig / 27.6 bar

125 FF Cast iron: 200 psig / 23.8 bar

150 RF Steel: 290 psig / 20 bar

300 RF Steel: 750 psi / 51.7 bar

600 RF and NPT Steel: 1470 psi / 101 bar

Outlet Pressure Ranges

See Table 2

Maximum Set Pressure

1470 psig / 101 bar or maximum body rating, whichever is lower

Minimum Set Pressure

4.0 in. w.c. / 10 mbar

Manometric Sensing Device Specifications

See Table 2

Flow Capacities

See Table 3

Maximum Shutoff Pressure Differential

1470 psig / 101 bar or maximum body rating, whichever is lower

Maximum Flowing Pressure Differential⁽¹⁾

BODY SIZE		MAXIMUM FLOWING PRESSURE DIFFERENCE	
NPS	DN	psig	bar
1	25	360	24.8
2	50	360	24.8
3	80	360	24.8
4	100	150	10.3
6	150	85	5.9
8	200	119	8.2
10	250	67	4.6

Accuracy

+/-2.5% for trip points at or below 1.45 psig / 0.10 bar,

+/-1% for trip points above 1.45 psig / 0.10 bar or

+/-5% for the piston Types 27 and 17

Response Time

<1 second

Process Temperature Capabilities⁽¹⁾

-22 to 180°F / -30 to 82°C

Pressure Registration

External

Pressure Sensing Connections

1/4 NPT

Vent Connection

1/4 NPT

Construction Materials

Body: WCC Steel or Cast iron

Bonnet: Steel

Valve Plug: Stainless steel

Valve Plug Seal O-ring: Nitrile (NBR)

Seat Ring: Stainless steel

Mechanism Box: Aluminum

First and Second Stage Mechanism: Steel

Diaphragm: Reinforced Nitrile (NBR)

Bellows: 316 Stainless steel

Piston: 316 Stainless steel

Approximate Weights

BODY SIZE		APPROXIMATE WEIGHT	
NPS	DN	lbs	kg
1	25	36	16
2	50	70	32
3	80	121	55
4	100	216	98
6	150	445	202
8	200	785	356
10	250	1272	577

Options

- Explosion-proof limit switch for Remote Alarm
- Manual Push Button Trigger Switch⁽²⁾
- Additional manometric device for extra pressure sensing

1. The pressure/temperature limits in this Bulletin or any applicable standard limitation should not be exceeded.

2. The push button connects at the same BM2 port as a Type BMS2 would.

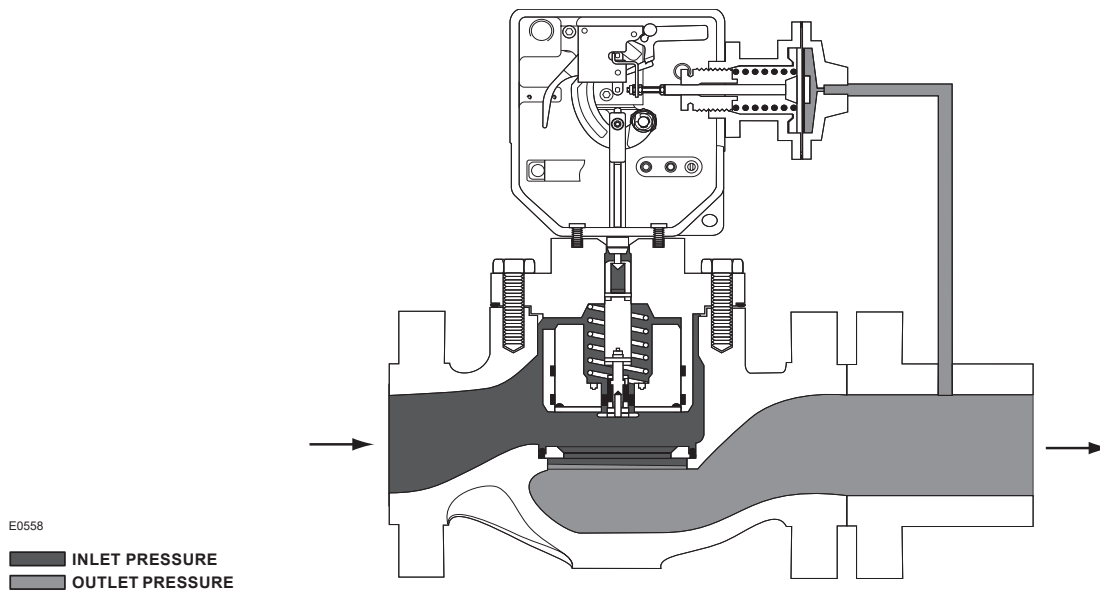

Figure 2. Type OSE Operational Schematic

Mechanism Box (BM1 or BM2)

The mechanism box (BM1 or BM2, see Figure 3) is designed to close the slam-shut valve. The detection of pressure variances is sensed by a double-stage trip mechanism. The first stage is the detection stage and will only trip when the system pressure reaches the set pressure of the manometric sensing device. The second stage is the power stage and once tripped by the first stage, the closing spring causes the valve plug to slam shut and remains closed until the valve is manually reset. If there are any inlet pressure variances or vibrations subjected to the second stage components, they are not transmitted to the first stage trip mechanism. This unique double-stage trip mechanism virtually eliminates nuisance tripping commonly found in other shut-off devices.

Manometric Sensing Device (Type BMS1 or BMS2)

Pressure from the system is sensed through control lines into the manometric sensing devices (Type BMS1 only, Type BMS2 only or Types BMS1 and BMS2, see Figure 3). If the sensed pressure reaches the setpoint of the manometric sensing device, the device will activate the tripping mechanism in the mechanism box and cause the valve to slam shut.

The BM1 can be configured with only the Type BMS1 to trip on overpressure (OPSO), underpressure (UPSO) or overpressure and underpressure (OPSO/UPSO). The BM2 can be configured with the Type BMS1 to trip on overpressure only (OPSO)

and the Type BMS2 to trip on overpressure (OPSO), underpressure (UPSO) and overpressure and underpressure (OPSO/UPSO) (refer to applications and construction guide in Table 1).

Remote Shutoff

Remote Tripping is accomplished using a 3-way solenoid valve installed in the control line of a Type BMS1 or BMS2 manometric device configured for underpressure protection (UPSO) or overpressure and underpressure protection (OPSO/UPSO). When de-energized, the solenoid valve allows the Type BMS manometric device to monitor the controlled pressure as if the solenoid valve was not present. When energized, the solenoid valve will be repositioned to connect the Type BMS manometric device to atmospheric pressure tripping the underpressure protection slam-shut setting.

Principle of Operation

Type OSE slam-shut valve serves to provide overpressure and/or underpressure protection by shutting down the flow to the downstream system. The slam-shut valve is typically installed upstream of a pressure reducing regulator as shown in Figures 4 and 5.

Pressure is registered on one side of the diaphragm, piston or bellows and is opposed by the setpoint control spring of the manometric sensing device. Type OSE slam-shut valve tripping pressure is determined by the setting of the control spring.

Type OSE

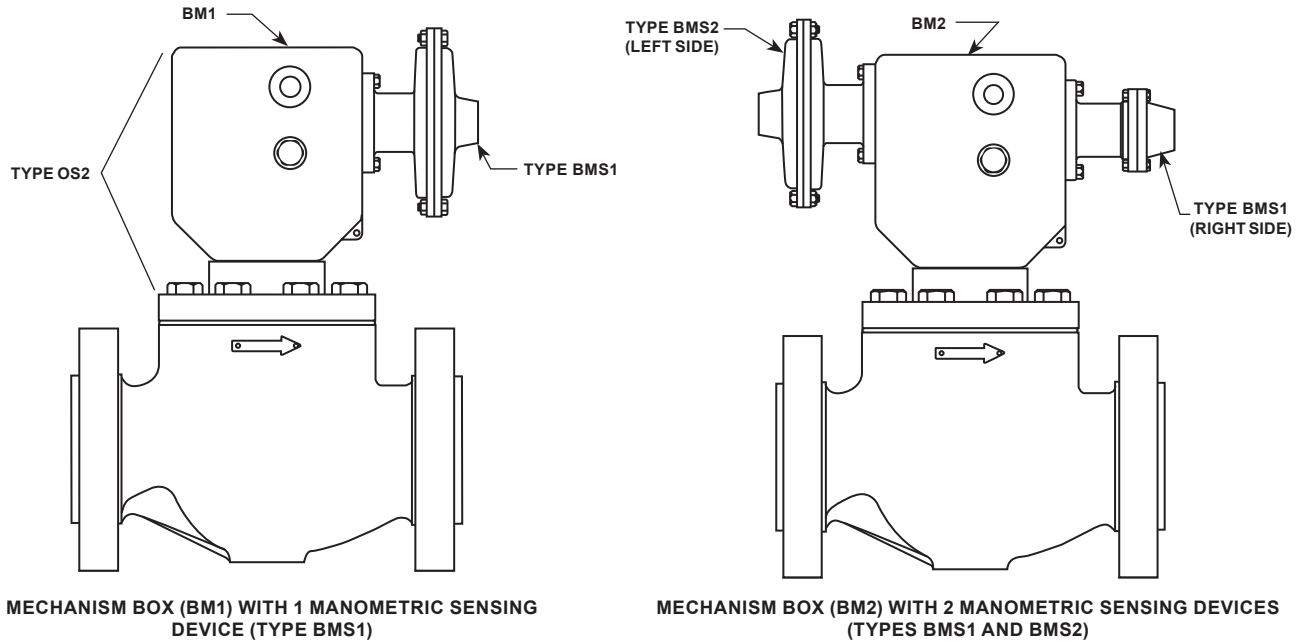

Figure 3. Types of Installation

Table 1. Applications and Construction Guide (See Figure 3)

APPLICATION	MECHANISM BOX REQUIRED	MANOMETRIC SENSING DEVICE REQUIRED	
Overpressure Shutoff (OPSO)	BM1	Type BMS1	----
Underpressure Shutoff (UPSO)		Type BMS1	----
Overpressure Shutoff (OPSO) and Underpressure Shutoff (UPSO)		Type BMS1 ⁽¹⁾	----
Overpressure Shutoff (OPSO) and Underpressure Shutoff (UPSO)	BM2	Type BMS1 ⁽²⁾	Type BMS2
Overpressure Shutoff (OPSO), Overpressure Shutoff (OPSO), Underpressure Shutoff (UPSO) and Dual Overpressure Shutoff (OSPO/OPSO)		Type BMS1 ⁽²⁾	Type BMS2 ⁽¹⁾

1. When using one manometric sensing device for both overpressure and underpressure shutoff, make sure that the difference between set pressures falls below the maximum range shown in Table 2.
2. When using two manometric sensing devices (Types BMS1 and BMS2) the Type BMS1 can only be used for high trip.

Overpressure: when the sensed pressure increases above the setpoint, the pressure on top of the diaphragm overcomes the spring setting and moves the manometric device stem.

Underpressure: when the sensed pressure decreases below the setpoint, the control spring pressure below the diaphragm overcomes the downstream pressure and pushes the diaphragm which moves the manometric device stem.

When the sensed pressure reaches the OPSO or UPSO setpoint, the manometric device stem contacts Pin D1 or D2 and triggers the detection stage which activates the second stage releasing the slam-shut valve plug. A tight and total shutoff is ensured by the plug seal O-ring closing on the seat ring and is helped by the “dash pot” effect between the bonnet skirt and the valve plug. A “dash pot” effect occurs when the valve plug closes by having both the closing spring and the inlet pressure pushing on top of the valve plug.

This is accomplished by ports around the skirt of the bonnet allowing inlet pressure above the valve plug.

Installation

The Type OSE should be installed in a horizontal position only, with the flow going down through the seat ring (flow arrow on body) with the mechanism box above the body. See Figure 4 for typical piping installations.

The Type OSE can be used along with a token relief valve to minimize unnecessary shutoff. The relief valve is set to open before the Type OSE slam-shut valve activates. This arrangement allows the relief valve to handle minor overpressure problems such as gas thermal expansion or seat leakage due to dirt moving through the system which may move out of the regulator during the next operating cycle. The slam-shut valve will activate if the regulator has a major malfunction with excessive gas flow that exceeds the token relief capacity.

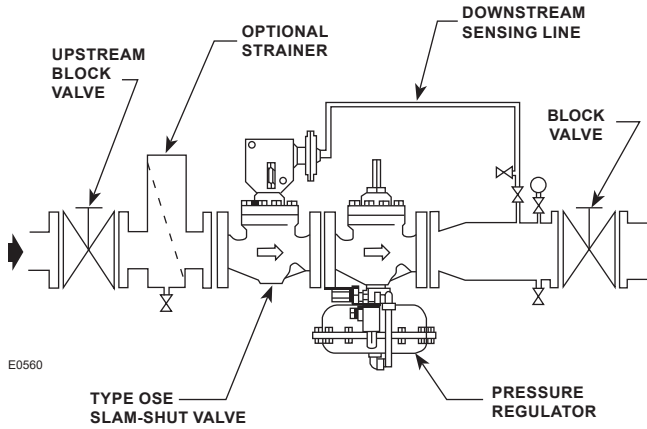

**OVERPRESSURE AND UNDERPRESSURE SHUTOFF
USING ONE MANOMETRIC DEVICE**

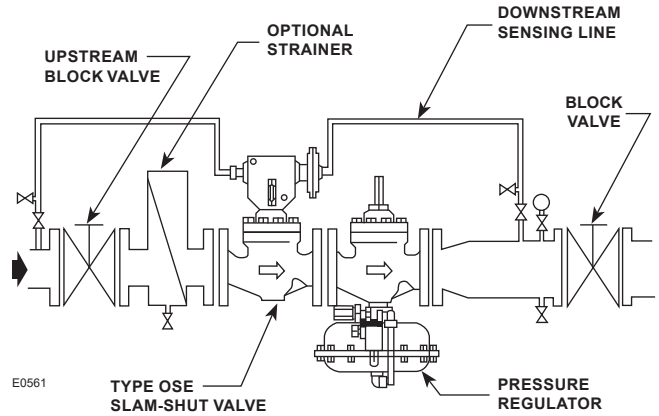

**MINIMUM/MAXIMUM UPSTREAM AND
DOWNSTREAM PRESSURE**

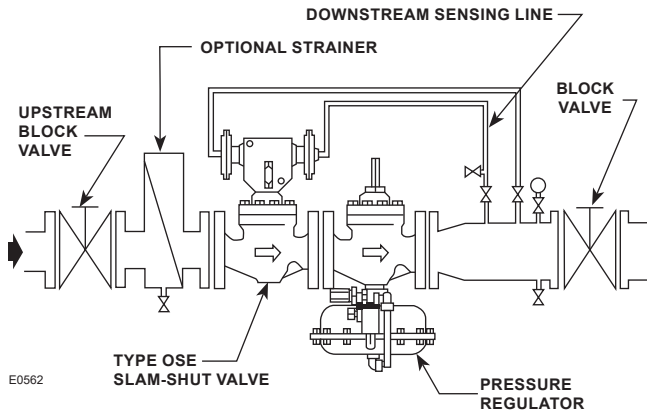

**OVERPRESSURE AND UNDERPRESSURE SHUTOFF
USING TWO MANOMETRIC DEVICES**

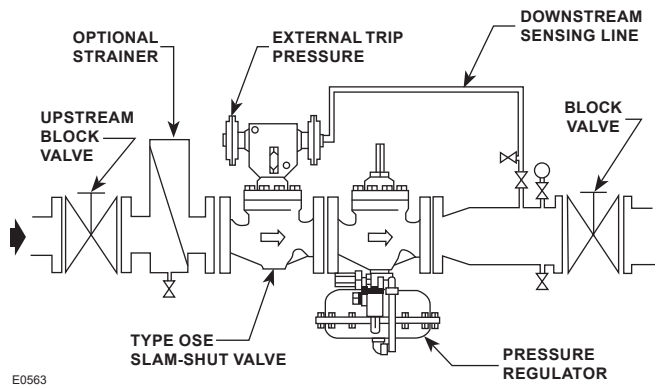

EXTERNAL SIGNAL

Figure 4. Typical Installations

Type OSE

Table 2. Spring Ranges, Part Numbers and Maximum and Minimum Pressures for Types BMS1 and BMS2

SPRING RANGE	SPRING COLOR	SPRING PART NUMBER	MANOMETRIC SENSING DEVICE TYPE	MANOMETRIC SENSING DEVICE STYLE	MAXIMUM SENSING INLET PRESSURE, psig / bar	RECOMMENDED SETPOINT DEADBAND, psig / bar ⁽¹⁾	MAXIMUM DIFFERENCE BETWEEN OVERPRESSURE AND UNDERPRESSURE, psig / bar ⁽²⁾	SPRING WIRE DIAMETER, In. / mm	SPRING FREE LENGTH, In. / mm
4.0 to 14 in. w.c. / 10 to 35 mbar	Purple	FA113195X12	162	Diaphragm	74 / 5.1	1.6 in. w.c. / 4 mbar	4.0 in. w.c. / 10 mbar	0.080 / 2.03	2.36 / 59.9
10 to 33 in. w.c. / 25 to 83 mbar	Orange	FA113196X12				2.0 in. w.c. / 5 mbar	10 in. w.c. / 25 mbar	0.105 / 2.67	2.36 / 59.9
18 in. w.c. to 2.0 psig / 45 mbar to 0.14 bar	Red	FA113197X12				4.0 in. w.c. / 10 mbar	20 in. w.c. / 50 mbar	0.120 / 3.05	2.36 / 59.9
1.0 to 3.5 psig / 70 mbar to 0.24 bar	Yellow	FA113198X12				5.6 in. w.c. / 14 mbar	24 in. w.c. / 60 mbar	0.135 / 3.43	2.36 / 59.9
1.7 to 5.6 psig / 0.12 to 0.39 bar	Green	FA113199X12				7.2 in. w.c. / 18 mbar	2.2 / 0.15	0.156 / 3.96	2.36 / 59.9
2 to 11 psig / 0.14 to 0.76 bar	Gray	FA113201X12				20 in. w.c. / 50 mbar	5.1 / 0.35	0.192 / 4.88	2.36 / 59.9
4 to 19 psig / 0.28 to 1.3 bar	Brown	FA113202X12				1.16 / 80 mbar	8.7 / 0.60	0.207 / 5.26	2.36 / 59.9
7 to 33 psig / 0.48 to 2.3 bar	Black	FA114139X12				2.47 / 0.17	16.0 / 1.1	0.250 / 6.35	2.36 / 59.9
15 to 75 psig / 1.0 to 5.2 bar	Blue	FA113200X12	71		235 / 16.2	5.08 / 0.35	36.3 / 2.5	0.177 / 4.50	2.36 / 59.9
31 to 161 psig / 2.1 to 11.1 bar	Brown	FA113202X12				10.2 / 0.70	79.8 / 5.5	0.207 / 5.26	2.36 / 59.9
59 to 235 psig / 4.1 to 16.2 bar	Black	FA114139X12				23.2 / 1.6	145 / 10.0	0.250 / 6.35	2.36 / 59.9
235 to 323 psig / 16.2 to 22.3 bar	Brown	FA113202X12	27	Piston	1470 / 101	43.5 / 3.0	Requires use of Type BMS1 or BMS2	0.207 / 5.26	2.36 / 59.9
323 to 588 psig / 22.3 to 40.5 bar	Black	FA114139X12				94.3 / 6.5		0.250 / 6.35	2.36 / 59.9
588 to 808 psig / 40.5 to 55.7 bar	Brown	FA113202X12	17	1470 / 101	102 / 7.0	0.207 / 5.26		2.36 / 59.9	
808 to 1470 psig / 55.7 to 101 bar	Black	FA114139X12			174 / 12.0	0.250 / 6.35		2.36 / 59.9	
81 to 323 psig / 5.60 to 22.3 bar	Brown	FA113202X12	236	Bellows	514 / 35.4	14.5 / 1.00	145 / 10.0	0.207 / 5.26	2.36 / 59.9
122 to 514 psig / 8.41 to 35.4 bar	Black	FA114139X12				36.3 / 2.5	290 / 20.0	0.250 / 6.35	2.36 / 59.9
257 to 1058 psig / 17.7 to 73.0 bar	Gray	FA113201X12				315	1058 / 73.0	72.5 / 5.0	479 / 33.0

1. Minimum suggested difference between slam-shut set pressure and normal operating pressure of the system.
 2. Maximum difference between overpressure and underpressure when using one manometric device (Type BMS1) with tripping hook. For underpressure and overpressure points greater than this maximum number, use a second manometric device (Type BMS2) for underpressure protection.

Capacity Information

Table 3 shows the flow capacities of the Type OSE slam-shut at 1 psi / 0.07 bar, 5 psi / 0.34 bar and 20 psi / 1.4 bar pressure drop. Flows are in thousands of SCFH at 60°F and 14.7 psia and in thousands of Nm³/h at 0°C and 1.01325 bar of 0.6 specific gravity natural gas.

To determine equivalent capacities for air, propane, butane or nitrogen, multiply the capacity by the following appropriate conversion factor: 0.775 for air, 0.628 for propane, 0.548 for butane or 0.789 for nitrogen. For gases of other specific gravities, multiply the given capacity by 0.775 and divide by the square root of the appropriate specific gravity.

If the capacity is desired in normal cubic meters per hour (Nm³/h) at 0°C and 1.01325 bar, multiply SCFH by 0.0268.

To determine the pressure drop for application specific flow rates, perform the following calculation:

$$\Delta P = P_1 \left[\sin^{-1} \left(Q / \left(C_g P_1 \sqrt{\frac{520}{GT}} \right) \right) \right]_{\text{DEG}} \cdot \frac{C_1}{3417} \Bigg]^2$$

or

$$\Delta P = P_1 \left[\sin^{-1} \left(Q / \left(C_g P_1 \sqrt{\frac{520}{GT}} \right) \right) \right]_{\text{RAD}} \cdot \frac{C_1}{59.64} \Bigg]^2$$

where,

- ΔP = pressure drop across the regulator, psi
- P₁ = absolute inlet pressure, psia (P₁ gauge + 14.7)
- Q = maximum gas flow rate, SCFH
- C_g = regulating gas sizing coefficient
- G = specific gravity of the gas
- T = absolute temperature of gas at inlet, °Rankine
- C₁ = flow coefficient

Table 3. Capacities

INLET PRESSURE, psig / bar	PRESSURE DROP, psig / bar	CAPACITIES IN THOUSANDS OF SCFH / Nm ³ /h OF 0.6 SPECIFIC GRAVITY NATURAL GAS						
		NPS 1 / DN 25	NPS 2 / DN 50	NPS 3 / DN 80	NPS 4 / DN 100	NPS 6 / DN 150	NPS 8 / DN 200	NPS 10 / DN 250
5 / 0.34	1 / 0.07	4.8 / 0.1	21.1 / 0.6	47 / 1.3	81.5 / 2.2	150 / 4	278 / 7.4	396 / 10.6
10 / 0.69		5.4 / 0.1	23.7 / 0.6	53 / 1.4	91.8 / 2.5	168 / 4.5	312 / 8.4	446 / 11.9
50 / 3.5		8.9 / 0.2	38.8 / 1	86.9 / 2.3	151 / 4	276 / 7.4	512 / 13.7	730 / 19.6
100 / 6.9		11.8 / 0.3	51.8 / 1.4	116 / 3.1	202 / 5.4	369 / 9.9	684 / 18.3	976 / 26.1
200 / 13.8		16.2 / 0.4	71.1 / 1.9	159 / 4.3	276 / 7.4	506 / 13.6	938 / 25.1	1337 / 35.8
300 / 20.7		19.7 / 0.5	86.1 / 2.3	193 / 5.2	335 / 9	614 / 16.4	1136 / 30.4	1620 / 43.4
400 / 27.6		22.6 / 0.6	98.9 / 2.6	222 / 5.9	385 / 10.3	705 / 18.9	1305 / 35	1861 / 49.9
500 / 34.5		25.2 / 0.7	110 / 3	247 / 6.6	429 / 11.5	785 / 21	1454 / 39	2074 / 55.5
600 / 41.4		27.5 / 0.7	120 / 3.2	270 / 7.2	468 / 12.5	858 / 23	1589 / 42.6	2266 / 60.7
800 / 55.2		31.7 / 0.8	139 / 3.7	311 / 8.3	539 / 14.5	988 / 26.5	1830 / 49	2610 / 69.9
1000 / 69.0	35.4 / 0.9	155 / 4.1	347 / 9.3	602 / 16.1	1103 / 29.6	2043 / 54.7	2913 / 78	
10 / 0.69	5 / 0.34	11.1 / 0.3	46.6 / 1.2	103 / 2.8	173 / 4.6	344 / 9.2	644 / 17.2	923 / 24.7
50 / 3.5		19.2 / 0.5	80.4 / 2.1	178 / 4.8	325 / 8.7	597 / 16.0	1111 / 29.8	1587 / 42.5
100 / 6.9		26.0 / 0.7	109 / 2.9	240 / 6.4	441 / 11.8	810 / 21.7	1504 / 40.3	2147 / 57.5
200 / 13.8		36.0 / 1.0	150 / 4.0	332 / 8.9	611 / 16.4	1121 / 30.0	2079 / 55.7	2966 / 79.5
300 / 20.7		43.7 / 1.2	182 / 4.9	404 / 10.8	743 / 19.9	1365 / 36.6	2526 / 67.7	3603 / 96.6
400 / 27.6		50.3 / 1.3	210 / 5.6	465 / 12.5	855 / 22.9	1567 / 42.0	2905 / 77.8	4144 / 111
500 / 34.5		56.1 / 1.5	234 / 6.3	518 / 13.9	954 / 25.6	1748 / 46.8	3240 / 86.8	4621 / 124
600 / 41.4		61.3 / 1.6	256 / 6.9	567 / 15.2	1040 / 27.9	1912 / 51.2	3544 / 95.0	5054 / 135
800 / 55.2		70.7 / 1.9	295 / 7.9	654 / 17.5	1203 / 32.2	2204 / 59.1	4084 / 109	5824 / 156
1000 / 69.0		78.9 / 2.1	330 / 8.8	730 / 19.6	1343 / 36.0	2462 / 66.0	4560 / 122	6503 / 174
50 / 3.5	20 / 1.4	34.2 / 0.9	143 / 3.8	329 / 8.8	565 / 15.1	1047 / 28.1	1937 / 51.9	2834 / 75.9
100 / 6.9		48.8 / 1.3	204 / 5.5	473 / 12.7	817 / 21.9	1506 / 40.4	2756 / 73.9	4032 / 108
200 / 13.8		69.5 / 1.9	290 / 7.8	678 / 18.2	1173 / 31.4	2157 / 57.8	3922 / 105	5737 / 154
300 / 20.7		85.4 / 2.3	357 / 9.6	835 / 22.4	1446 / 38.8	2655 / 71.2	4815 / 129	7045 / 189
400 / 27.6		98.8 / 2.6	413 / 11.1	966 / 25.9	1675 / 44.9	3074 / 82.4	5568 / 149	8146 / 218
600 / 41.4		121 / 3.2	506 / 13.6	1187 / 31.8	2058 / 55.2	3775 / 101	6830 / 183	9992 / 268
800 / 55.2		140 / 3.7	585 / 15.7	1372 / 36.8	2380 / 63.8	4365 / 117	7892 / 212	11,547 / 309
1000 / 69.0		156 / 4.2	655 / 17.6	1536 / 41.2	2664 / 71.4	4884 / 131	8828 / 237	12,916 / 346

Table 4. Representative Wide-Open Flow Coefficients

BODY SIZE		PORT DIAMETER		FLOW COEFFICIENT			BYPASS FLOW COEFFICIENT		IEC SIZING COEFFICIENT		
NPS	DN	IN.	MM	C _g	C _v	C _t	C _g	C _t	X _t	F _a	F _i
1	25	1.83	30	505	14.4	35	25.7	35	0.775	1.0	0.89
2	50	2.00	51	2210	60.6	35	25.7	35	0.775	1.0	0.89
3	80	3.15	80	4670	141	33	25.7	35	0.689	1.0	0.89
4	100	3.94	100	7860	244	32	25.7	35	0.648	1.0	0.89
6	150	5.91	150	14,850	454	33	25.7	35	0.648	1.0	0.89
8	200	7.87	200	28,830	833	34.6	133	32.8	0.580	1.0	0.89
10	250	9.84	250	42,180	1188	35.5	133	32.8	0.797	1.0	0.89

Type OSE

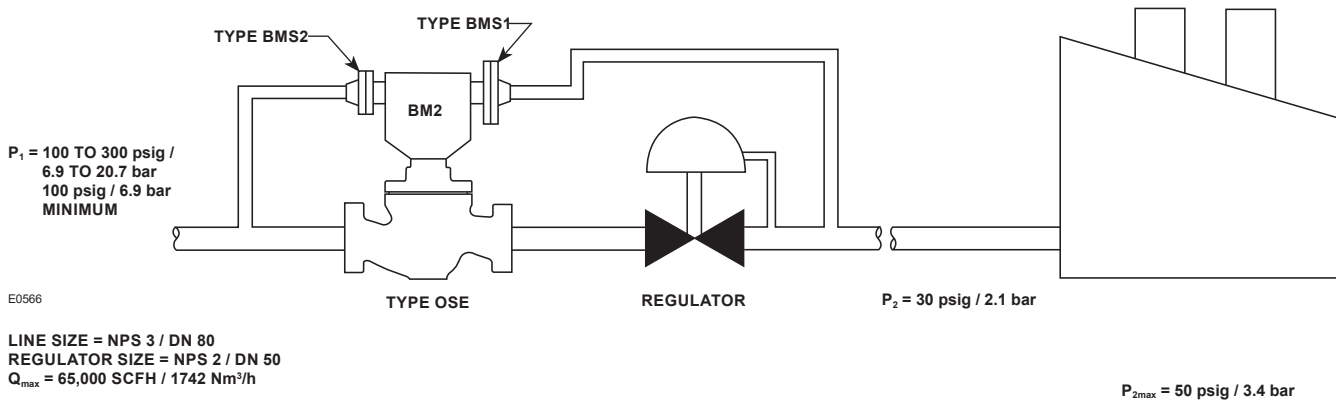

Figure 5. Type OSE Sizing Example

Sizing Example

Refer to Figure 5. In this example, natural gas is being supplied to a single factory. The normal pressure supplied to the factory is 30 psig / 2.1 bar and maximum pressure to the equipment in the factory is 50 psig / 3.5 bar. A Type OSE slam-shut valve will be used to protect the equipment in case of an overpressure incident. The slam-shut valve will also be used to shut off the flow on underpressure in case the transmission line falls to 100 psig / 6.9 bar inlet pressure (thus preventing further loss of transmission line pressure and possible loss of all line pressure).

1. Gather necessary data:

Conditions:

P_{1max}	= 300 psig / 20.7 bar
P_{1min}	= 100 psig / 6.9 bar
$P_{2reg\ set}$	= 30 psig / 2.1 bar
P_{2max}	= 50 psig / 3.4 bar
End connections: CL300 RF	
Natural Gas	
SG	= 0.6
T_{normal}	= 60°F / 15.6°C
Q_{max}	= 65,000 SCFH / 1742 Nm ³ /h

2. Determine appropriate body size of the Type OSE:

Assuming that the same NPS 2 / DN 50 body size as the regulator would be ideal for the slam-shut, the pressure drop equation will be used to calculate the worst case pressure drop across the Type OSE. Using the maximum flow of 65,000 SCFH / 1742 Nm³/h at the minimum inlet pressure of 100 psig / 6.9 bar and the NPS 2 / DN 50 flow coefficients for C_g of 2210 and C_1 of 35, the pressure drop equation reveals a maximum pressure drop of 1.6 psi / 0.11 bar.

When sizing the regulator for capacity at the maximum flow rate and minimum inlet pressure, the 1.6 psi / 0.11 bar would be subtracted from P_{1min} to account for the pressure drop across the Type OSE.

3. Select appropriate manometric device:

Table 2 lists the different selections for the manometric sensing device (Type BMS1 or BMS2). For the overpressure protection setting of 50 psig / 3.5 bar, choose a Type 071 manometric device with a 15 to 75 psig / 1.0 to 5.2 bar spring. This spring is chosen because it has less setpoint drift than the 30 to 160 psig / 2.1 to 11.0 bar spring.

For the underpressure protection of the transmission line, a separate manometric device must be used. A Type 236 manometric device can be used with a 81 to 323 psig / 5.6 to 22.3 bar spring setting for underpressure protection.

4. Check the pressure ratings:

Because of the flange limitations Type OSE with CL300 RF flanged end connections has a maximum pressure rating of 750 psig / 51.7 bar, which will safely handle the 300 psig / 20.7 bar maximum inlet pressure. The Type 071 manometric device will hold pressure up to 235 psig / 16.2 bar (see Table 2). The slam-shut valve will shut the pressure off at 50 psig / 3.5 bar, preventing an overpressure of the Type 071 and the downstream equipment. The Type 236 for underpressure protection could see the full inlet pressure of 300 psig / 20.7 bar. Table 2 shows that the maximum pressure rating for the Type 236 is 514 psig / 35.4 bar, so it will safely handle the maximum inlet pressure.

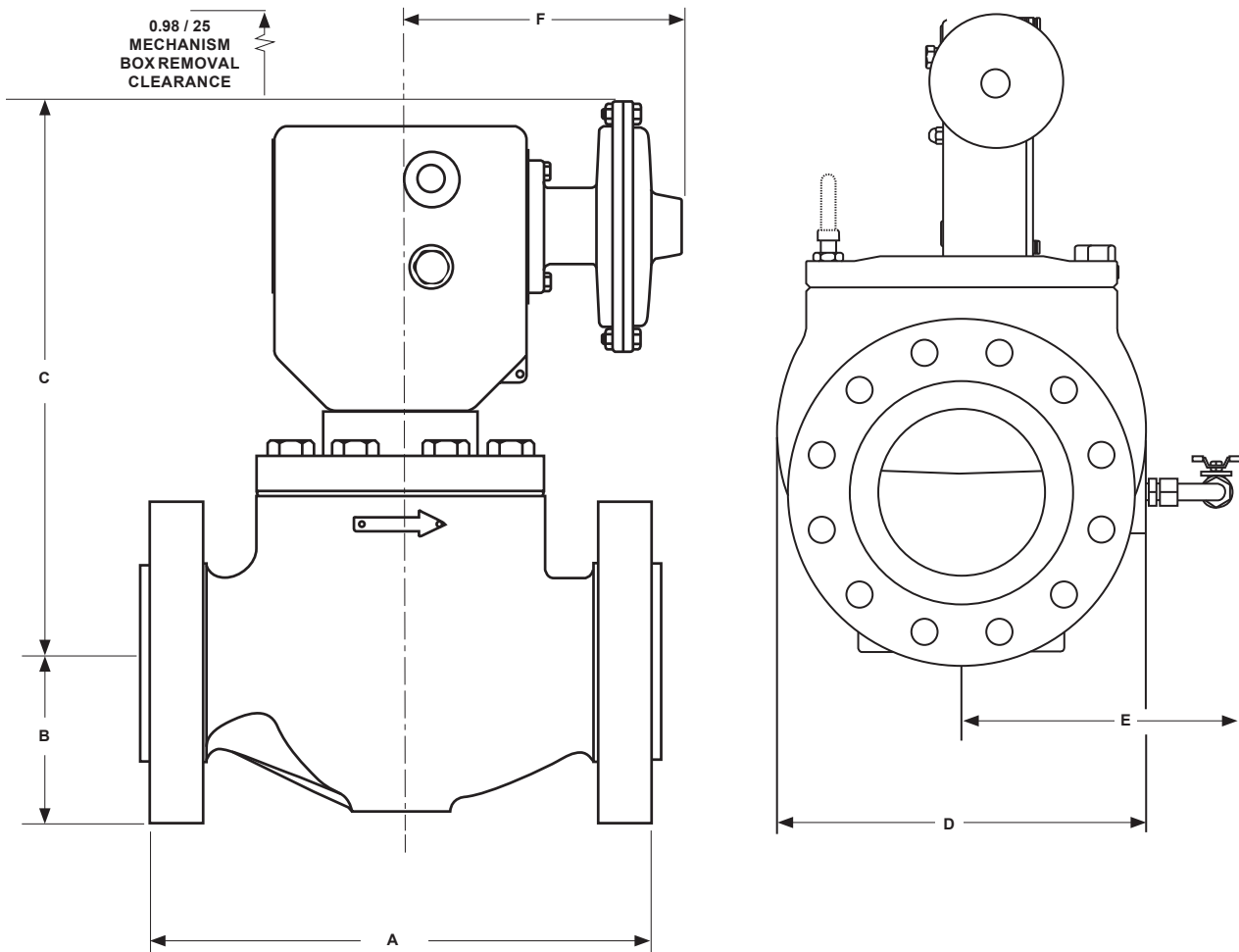

IN. / mm

Figure 6. Type OSE Dimensions

Table 5. Type OSE Dimensions

BODY SIZE, NPS / DN	DIMENSION, IN. / mm										E	F MAX
	A				B			C MAX	D			
	NPT	CL125 FF, CL150 RF	CL300 RF	CL600 RF	CL125 FF, CL150 RF	CL300 RF	CL600 RF		CL125 FF, CL150 RF	CL250 RF, CL300 RF, CL600 RF		
1 / 25	8.25 / 210	7.25 / 184	7.75 / 197	8.25 / 210	2.2 / 56	2.5 / 63	2.5 / 63	12.6 / 320	4.6 / 117	4.9 / 124	----	8.8 / 223
2 / 50	11.25 / 286	10 / 254	10.5 / 267	11.25 / 286	3.0 / 76	3.3 / 84	3.3 / 84	13.2 / 335	6.0 / 152	6.5 / 165		
3 / 80	----	11.75 / 298	12.5 / 317	13.25 / 337	3.7 / 94	4.1 / 104	4.1 / 104	14.2 / 361	7.5 / 190	8.3 / 211		
4 / 100		13.88 / 353	14.5 / 368	15.5 / 394	4.5 / 114	5.0 / 127	5.0 / 127	16.0 / 406	9.0 / 229	10.0 / 254		
6 / 150		17.75 / 451	18.62 / 473	20 / 508	5.5 / 140	6.6 / 168	6.6 / 168	16.2 / 411	14.0 / 356	14.0 / 356		
8 / 200	----	21.38 / 543	22.38 / 568	24 / 610	6.8 / 173	7.5 / 190	8.2 / 208	22.8 / 579	17.6 / 447	17.6 / 447	13.2 / 335	10.0 / 253
10 / 250		26.5 / 673	27.9 / 708	29.6 / 752	8.0 / 203	8.7 / 221	10.0 / 254	26.3 / 668	19.6 / 498	19.6 / 498	14.3 / 363	

Type OSE

Ordering Information

When ordering, complete the ordering guide on this page. Refer to the Specifications section on page 2. Review the description to the right of each

specification and the information in each referenced table or figure. Specify your choice whenever a selection is offered.

Ordering Guide

Body Size (Select One)

- NPS 1 / DN 25***
- NPS 2 / DN 50***
- NPS 3 / DN 80***
- NPS 4 / DN 100***
- NPS 6 / DN 150***
- NPS 8 / DN 200**
- NPS 10 / DN 250**

Body Material and End Connection Style (Select One)

Cast Iron Body

- NPT (NPS 1 and 2 / DN 25 and 50 only)***
- CL125 FF (NPS 1 to 6 / DN 25 to 150 only)**

WCC Steel Body

- NPT (NPS 1 and 2 / DN 25 and 50 only)***
- CL150 RF***
- CL300 RF**
- CL600 RF**

Slam-Shut Trip Pressure Setting (Select One)

Overpressure Protection Only (OPSO)

- Supply setpoint required _____

Underpressure Protection Only (UPSO)

- Supply setpoint required _____

Overpressure and Underpressure Protection (OPSO/UPSO)

- Supply overpressure setpoint required _____
- Supply underpressure setpoint required _____

Overpressure Protection (OPSO), Overpressure and Underpressure Protection (OPSO/UPSO), Dual Overpressure Shutoff (OSPO/OPSO)

- Supply overpressure setpoint required _____
- Supply overpressure setpoint required _____
- Supply underpressure setpoint required _____

Explosion-Proof Limit Switch (Optional)

- Yes**

Manual Push Button Trigger Switch (Optional)

- Yes**

Ordering Guide (continued)

Regulators Quick Order Guide	
***	Readily Available for Shipment
**	Allow Additional Time for Shipment
*	Special Order, Constructed from Non-Stocked Parts. Consult your local Sales Office for Availability.
Availability of the product being ordered is determined by the component with the longest shipping time for the requested construction.	

Specification Worksheet	
Application:	
Specific Use	_____
Line Size	_____
Gas Type and Specific Gravity	_____
Gas Temperature	_____
Pressure:	
Maximum Inlet Pressure (P_{1max})	_____
Minimum Inlet Pressure (P_{1min})	_____
Downstream Pressure Setting(s) (P_2)	_____
Maximum Flow (Q_{max})	_____
Performance Required:	
Accuracy Requirements?	_____
Need for Extremely Fast Response?	_____
Other Requirements: _____	

✉ Webadmin.Regulators@emerson.com

🔍 Fisher.com

📘 Facebook.com/EmersonAutomationSolutions

🌐 LinkedIn.com/company/emerson-automation-solutions

🐦 Twitter.com/emr_automation

Emerson Automation Solutions

Americas

McKinney, Texas 75070 USA
T +1 800 558 5853
+1 972 548 3574

Europe

Bologna 40013, Italy
T +39 051 419 0611

Asia Pacific

Singapore 128461, Singapore
T +65 6777 8211

Middle East and Africa

Dubai, United Arab Emirates
T +971 4 811 8100

D102356X012 © 1997, 2023 Emerson Process Management Regulator Technologies, Inc. All rights reserved. 05/23.

The Emerson logo is a trademark and service mark of Emerson Electric Co. All other marks are the property of their prospective owners. Fisher™ is a mark owned by Fisher Controls International LLC, a business of Emerson Automation Solutions.

The contents of this publication are presented for informational purposes only, and while every effort has been made to ensure their accuracy, they are not to be construed as warranties or guarantees, express or implied, regarding the products or services described herein or their use or applicability. All sales are governed by our terms and conditions, which are available upon request. We reserve the right to modify or improve the designs or specifications of such products at any time without notice.

Emerson Process Management Regulator Technologies, Inc does not assume responsibility for the selection, use or maintenance of any product. Responsibility for proper selection, use and maintenance of any Emerson Process Management Regulator Technologies, Inc. product remains solely with the purchaser.

