

July 2018

Types BLE and BLX Throttle Valves

SUMMARY

Introduction	1
Characteristics	2
Labelling	2
Dimensions and Weights	3
Operation	4
Installation	4
Commissioning	5
Maintenance	6
Spare Parts	10

WARNING

Failure to follow these instructions or to properly install and maintain this equipment could result in an explosion and/or fire causing property damage and personal injury or death.

Fisher™ throttle valve device must be installed, operated and maintained in accordance with federal, state and local codes, rules and regulations and Emerson Process Management Regulator Technologies, Inc. (Emerson) instructions.

If the throttle valve vents gas or a leak develops in the system, service to the unit may be required. Failure to correct trouble could result in a hazardous condition.

Call a gas service person to service the unit. Only a qualified person must install or service the device.

INTRODUCTION

Scope of the Manual

This manual provides installation, startup, maintenance and parts ordering information for the Types BLE and BLX throttle valves.

Product Description

The Type BLE throttle valve functions as a bypass on transmission pressure reducing stations up to 100 bar.

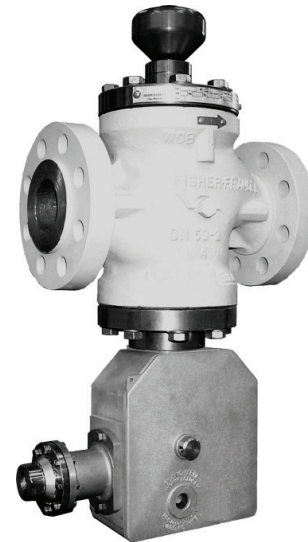

Figure 1. Type BLE-BLX Throttle Valve

The Type BLX is equipped with an integral slam-shut valve Type OS2 used to cut off pressure flow in the case of outlet overpressure.

The Type BLE version consists of:

- A body (Type E body) with removable orifice, closed with a cap also serving as a valve guide.
- A balanced valve plug, opened by fluid flow, linear characteristic.
- A valve plug/orifice nitrile disc plug, removable and tight shutoff.
- A valve plug guide with plastic rings and manual handwheel.
- The button serves as an opening indicator.

The Type BLX version, equipped with slam-shut Type OSE with release relay Type OS2:

- A body (Type X body) including an inferior opening for lodging the slam-shut.

The slam-shut includes:

- A valve plug/orifice assembly with connecting part.
- A release relay Type OS2 including a mechanism box (BM and a safety manometric box (BMS)).

The Types BLE and BLX are in conformity with the Pressure Equipment Directive PED 2014/68/UE and are classified in Category IV.

Types BLE and BLX

CHARACTERISTICS

Table 1. Types BLE and BLX Trottle Valve Characteristics

OPERATING PRESSURE			SLAM SHUT (TYPE BLX ONLY)		
Body	PS	100 bar max	European EN Standard		EN 14382
Associated BMS* according to size	PSD	10 to 100 bar	Operation Class		A or B (see Figure 2)
Maximum inlet pressure	Pumax	100 bar	Response Time		ta < 1 s
Type	DS	Differential strength**	Accuracy	Diaphragm	AG
OPERATING TEMPERATURE	TS	-30 / +71 °C		Bellows	
Body Size	DN	25, 50, 80, 100		Piston	5
THROTTLE VALVE			Set Pressure Range		Wdu - Wdo 0.010 / 100 bar
Inlet Pressure	Pu	100 bar max	Rearming	Manual after rectification of fault	
Maximum Differential	ΔP max	100 bar	Travel Indicator	On mechanism box	
FLUID					
Groups 1 and 2 according to PED 2014/68/EU, gas 1 sts and 2nd family according to EN437 or other gases (compressed air, nitrogen). The gas must be non corrosive, clean (filtration on inlet size necessary) and dry.					

* BMS: Safety Manometric Box
** Differential strength (according to BMS choice)

B69a

Table 2. Flow Coefficients

DN	25	50	80	100
Qf	230	970	2150	3367
Cg	450	1880	4170	6500
C1	35			

B69b

Materials

Body	Steel
Bonnet	Steel
Screw holder	Bronze
Orifice	Stainless steel
Valve plug	Steel
Disc plug	Nitrile

Connections

Inlet / Outlet Class 600B (ANSI 600 RF)
Class 300B (ANSI 300 RF)
Class 150B (ANSI 150 RF)
Other connections available (contact factory)
PN 16 B, 25 B, 40 B

LABELLING

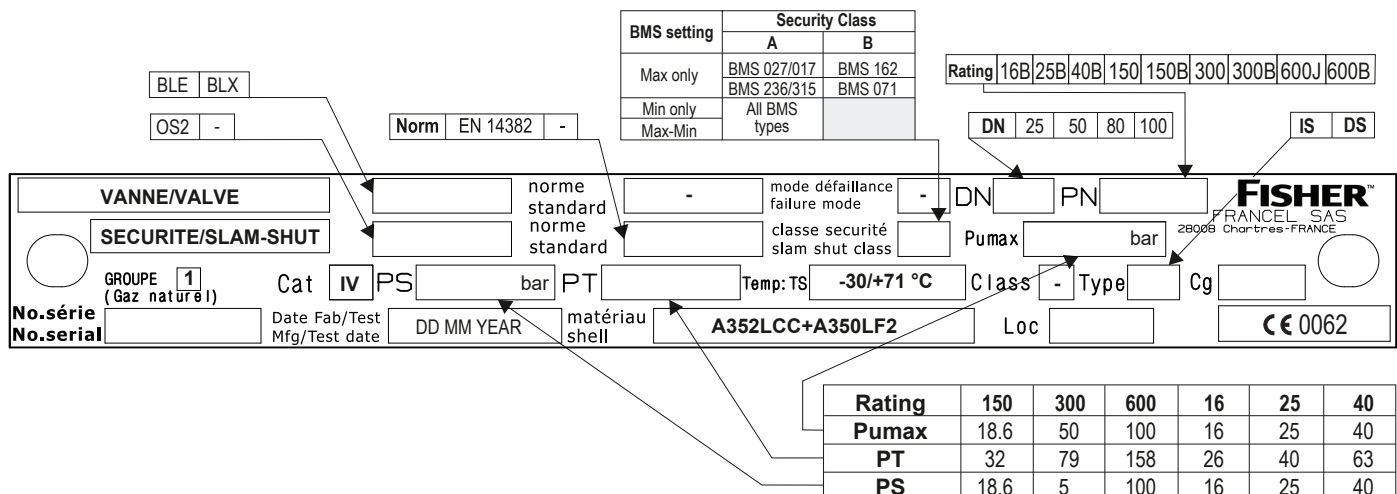

Figure 2. Label for Types BLE and BLX Trottle Valve

DIMENSIONS AND WEIGHTS

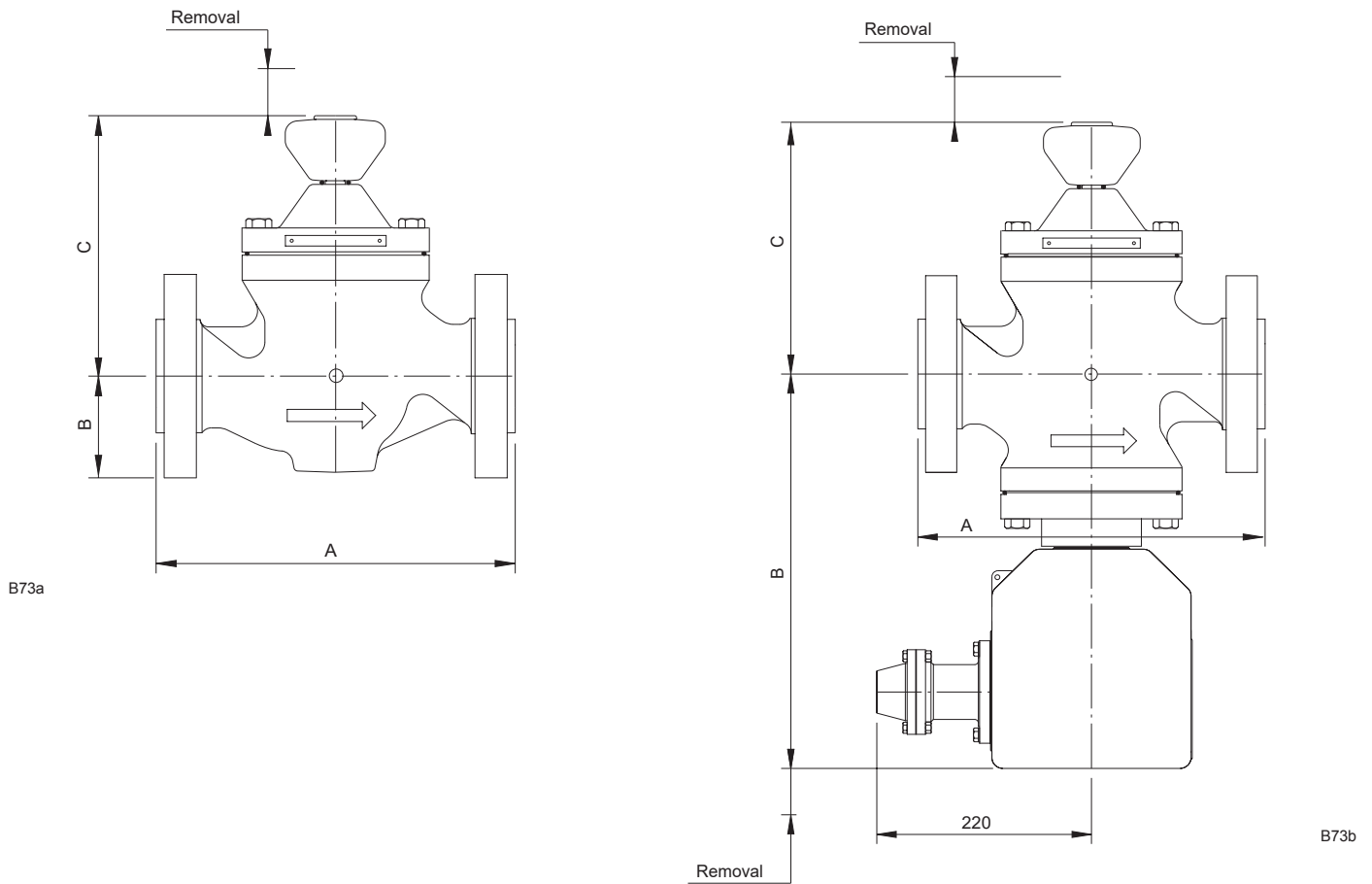

Figure 3. Types BLE and BLX Trottle Valve Dimensions

Table 3. Types BLE and BLX Trottle Valve Dimensions and Weights

DN	CLASS	DIMENSIONS TYPES BLE (WITHOUT SLAM-SHUT) AND BLX (WITH SLAM-SHUT)					WEIGHT (kg)		
		A (finish B)	B		C		Removal	BLE	BLX
BLE	BLX		BLE	BLX					
25	150	185	54	315	183	196	55	12	20
	300	197	62					13	21
	600	210						14	22
50	150	254	76	330	196	213	75	22.5	36
	300	267	83					24.5	38
	600	287						26.5	40
80	150	298	95	361	223	241	95	43	57
	300	318	105					49	63
	600	337						51	65
100	150	352	137	410	267	289	120	80	115
	300	368						92	127
	600	394						96	131

Types BLE and BLX

OPERATION

Type BLE or BLX

The Type BLE throttle valve is a balanced plug type, opened by pressure flow.

The opening control is manually performed by a torque handwheel (approx. 4 N·m). 1 handwheel turn = 2 mm travel (see Table 4).

Tight shutoff is achieved by a nitrile disc plug situated on the valve plug. The disc plug and orifice are easily replaced.

The opening control is progressive to start and then linear. In closed position, an O-ring situated below the handwheel protects the control screw for exterior corrosion.

A rotation of 1/8 turn after contact with the valve plug / orifice is sufficient to assure tight shutoff.

Slam-Shut (Type BLX)

The pressure of the zone to be protected (in general the pipeline, outlet side of the regulator and after the slam-shut) reacts on the safety manometric box (BMS).

If the pressure rises above the set range, the release relay releases the valve plug.

Due to the action of the closing spring and the fluid (trying to close), the valve plug closes on the orifice.

The gas flow is obstructed until the fault has been corrected and the mechanism box manually rearmed.

Equal pressure balance on inlet and outlet sides are necessary to reopen the valve plug.

The mechanism box is rearmed after opening the internal bypass.

Rearming and balancing are achieved at the same time.

Table 4. Opening Control Measurements

DN	NO. OF TURNS	TRAVEL
25	4	8
50	7.5	15
80	11.5	23
100	15	30

INSTALLATION

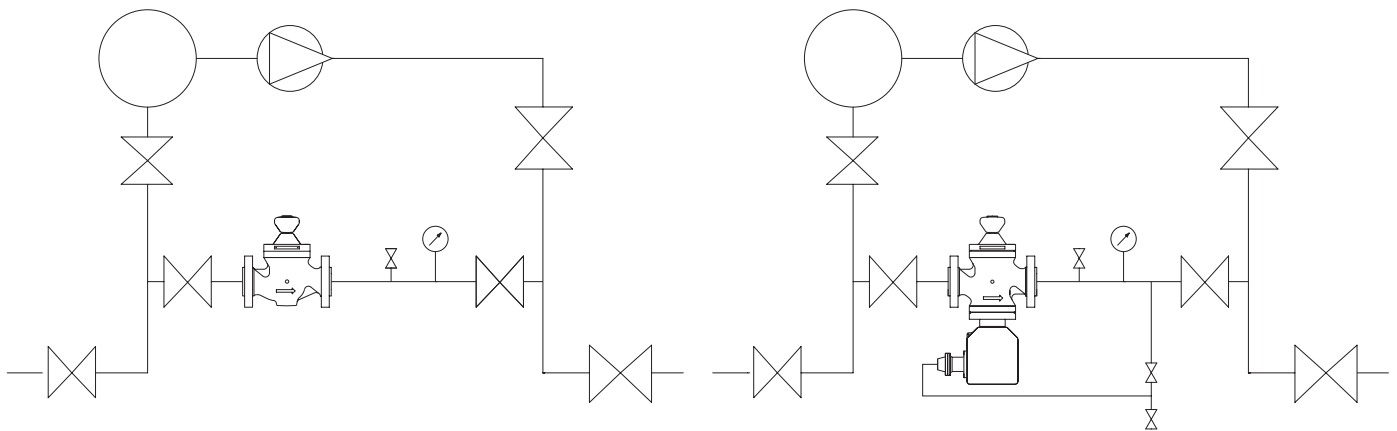

Figure 4. Types BLE and BLX Installation

B75



WARNING

Personal injury or equipment damage, due to bursting of pressure-containing parts may result if this device is overpressured or is installed where service conditions could exceed the limits given in the Specification section and on the appropriate nameplate or where conditions exceed any rating of the adjacent piping or piping connections. To avoid such injury or damage, provide pressure-relieving or pressure-limiting devices to prevent service conditions from exceeding those limits. Also, be sure the installation is in compliance with all applicable codes and regulations.

Additionally, physical damage to the device can cause personal injury and property damage due to bursting of pressure-containing parts. To avoid such injury and damage, a possible approach could be e.g. install the device in a safe location.

Respect the direction of the fluid flow and the position of the valve (fluid opening the throttle valve plug).

All interventions on the equipment should only be performed by qualified and trained personnel.

Type BLE version, the valve is to be installed on horizontal or vertical pipeline with the control handwheel in a top, bottom or lateral position.

Type BLX version, the valve is to be installed on a horizontal pipeline with the control handwheel in a top or bottom position.

Install according to direction of fluid flow (arrow). Opened by fluid flow.

When assembling with adjacent elements care must be taken not to create pressure force on the body and the assembling elements (bolts, O-rings, flanges) should be compatible with the geometry and working conditions of the equipment.

If the case arises a support must be used to avoid pressure force on the body (a support can be installed under the flanges).

No modification should be made to the structure of the equipment (drilling, grinding, soldering...).

Verify that the inlet side is protected by an appropriate device(s) to avoid exceeding the limits of utilization (PS, TS).

Verify that the limits of utilization correspond to the appropriate operating conditions.

Type BLX version, verify that the safety manometric box (BMS) and spring correspond to the appropriate operating conditions on the outlet side of the throttle valve.

The equipment should not receive any type of shock, especially the handwheel and release relay.

Fire, seismic and lightning are not taken into consideration in standard regulators. If required, a special product selection and/or specific calculations may be supplied according to specific requirements.

The user should verify or carry out a protection adapted to the environment.

COMMISSIONING



WARNING

All interventions on the equipment should only be performed by qualified and trained personnel.

Be sure to slowly introduce pressure into the system to prevent downstream overpressure due to potential rapid pressure increase. Pressure gauges should always be used to monitor downstream pressure during startup.

Preliminary Verifications

Start-up positions

- Inlet and outlet station valves
→ Open
- Expansion line(s)
→ *Operating*

Type BLE (without slam-shut)

- Type BLE inlet valve
→ Closed
- Type BLE throttle valve
→ Closed

Positions before commissioning

- Expansion line(s)
→ Isolated
- Type BLE inlet valve
→ Open

The equipment is ready for commissioning.

Commissioning

- Type BLE throttle valve
→ **Open slowly observing the manometer outlet side of the station.**

The equipment is commissioned.

Type BLX (with slam-shut)

- Type BLX inlet valve
→ Closed
- Type BLX throttle valve
→ Closed
- Type BLX slam-shut
→ Closed
- Impulse line isolation valve
→ Closed
- Impulse line atmospheric valve
→ Opened

Types BLE and BLX

Slam-shut Setpoint Verification

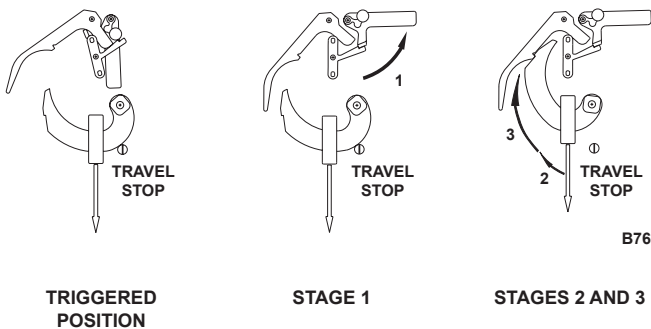

Figure 5. Slam-Shut Positions

Using the atmospheric valve, inject a pressure equal to the pressure required for the regulator.

- 1st release relay stage (BM)
→ Set (Stage 1)
- Slam-shut valve plug
→ Open (Stages 2 and 3)
→ Progressively increase the pressure to reach tripping
→ Adjust the setting if necessary
(see D103683X012-OS2-IM manual)

Note the setpoint value on the equipment or mark it on a commissioning document.

Positions Before Commissioning

- Expansion line(s)
→ Isolated
- Impulse line isolation valve
→ Open
- Impulse line atmospheric valve
→ Closed
- Valve plug
→ Closed

The equipment is ready for commissioning.

Commissioning

- Type BLX inlet valves
→ Open slowly
- 1st release relay stage
→ Set (Stage 1)
- Slam-shut internal bypass
→ Open slowly (Stage 2)
- Slam-shut valve plug
→ Open (Stage 3)

- Outlet valve
→ Open slowly
- Type BLX throttle valve
→ Open slowly observing the manometer outlet side of the station.

The equipment is commissioned.

It is recommended to seal the release relay.

MAINTENANCE

WARNING

To avoid personal injury or property damage from sudden release of pressure, isolate the throttle valve from the pressure system and release all pressure from the main valve before performing maintenance operations.

Servicing Check

Recommended frequency:

- **Types BLE and BLX** Once every 2 years for the throttle valve
- **Type BLX** Twice yearly minimum for the slam-shut

Verification:

- **Types BLE and BLX** Verification manual opening of the valve
Tight shutoff of the throttle valve plug
- **Type BLX** Triggering and setpoint verification
Valve plug tight shutoff

Departure positions

- Inlet valve → Closed
- Outlet valve → Closed
- Servicing valve → Closed
- Throttle valve (Types BLE, BLX) → Closed
- Slam-shut (Type BLX) → Open

Tight shutoff verification of the throttle valve (Types BLE - BLX)

- Inlet valve → Open
- Servicing valve → Open
- Servicing valve → Closed
- Throttle valve → Open very slowly and close when outlet regulator pressure is achieved
- Throttle valve Observe the evolution of outlet pressure

Verification of tight shutoff and slam-shut triggering (Type BLX)

- Throttle valve → Open very slowly to slam-shut set point without exceeding permitted limits

Table 5. Troubleshooting for Type BLE Throttle Valve

SYMPTOMS	CAUSE	ACTIONS
If outlet pressure increases	Leak in the throttle valve plug	Control the throttle valve plug Control the throttle orifice or contact after-sales
If outlet pressure is constant	Throttle valve plus is tight shutoff	

Table 6. Troubleshooting for Type BLX Throttle Valve

SYMPTOMS	CAUSE	ACTIONS
If the slam-shut valve plug will not close	Operation faulty	Control the release relay Control the slam-shut valve plug or contact after-sales
If the slam shut valve plug closes	Operation correct	Observe the evolution of the outlet pressure (control tightness)
If the slam-shut valve plug outlet pressure decreases	External leak	Locate and seal the leak or contact after-sales
If the slam-shut valve plug outlet pressure is constant	Purge the outlet side of the throttle valve	Observe the evolution of the outlet pressure (control tightness)
If the outlet pressure increases	Internal leak	Control the slam-shut valve plug Control the orifice Control the internal bypass or contact after-sales
If the outlet pressure is constant	Valve plug is tight shutoff	

Table 7. Torque Specifications for Screw (key 1)

TIGHTENING SCREW KEY 1 (BONNET (KEY 2) CONNECTING PART (KEY 18))			
DN	DIMENSIONS	SPANNER (INCHES)	TORQUE (N•m)
25	9/16 - 12 x 1 3/4	13/16"	110
50	1/2 - 13 x 1 1/2	3/4"	110
80	5/8 - 11 x 1 3/4	15/16"	175
100	3/4 - 10 x 3	1"1/8	200

Table 8. Torque Specifications for Screws (keys 4 & 15)

KEY	TIGHTENING	
	DIMENSIONS	TORQUE (N•m)
4	M4 and M5	4
	M6	6
15	M8	15

Table 9. Torque Specifications for Bypass (key 19)

TIGHTENING BYPASS (KEY 19)	
DN	TORQUE (N•m)
25	14
50	
80	20
100	24

Types BLE and BLX

MAINTENANCE

Disassembly of the Throttle Valve

Recommended frequency:

Every 4 to 6 years (or less depending on operating conditions)



CAUTION

In the case of BMS 162 or 071, it is strongly recommended to check the condition of the diaphragm once a year.

Verification:

- Condition of O-rings, valve disc plug, lubrication

Replacement:

- O-rings, valve disc plug

Tools:

- 2 flat spanners according to DN (see Table 7)
- Six-sided spanners numbers 3, 4, 5, 6, 13, 24
- Box spanner numbers 13, 19

Precautions Before Disassembly

- Close inlet and outlets valves.
- Valve plug open
Open fully the valve plug by turning the knob (key 9) until metal/metal contact is made with the valve plug (key 13) on the bonnet (key 2)
- Bleed off outlet pressure
- Bleed off inlet pressure

Type BLE (without slam-shut)

- Unscrew screws (key 1) from bonnet (key 2)
- Remove bonnet/valve plug assembly
- Remove orifice (key 3)



WARNING

With knob (key 9) in bottom position (equipment turned upside down) the orifice (key 3) descends with the bonnet/valve plug assembly and is just centered by the columns on the edge of the orifice (key 3).

- Unscrew screws (key 4) from pad retainer (key 5) (only one for DN 25)

- Remove valve plug (key 6)
- Remove the valve plug support (key 7) (wrench DN 25 and six-sided spanner for DN 50 and 80)
- Unscrew safety nut (key 8) while holding knob (key 9)
- Recover the lower stop part (key 10) (thick washer, cage, thin washer) and fully unscrew the knob (key 9) to remove the knob (key 9)/control stem (key 11) assembly
- Remove the valve plug plate (key 13)
- Recover the upper stop part (key 12) (thin washer, cage, thick washer)

Type BLX (with slam-shut)

As well as above operations

- Unscrew impulse connector IS
- Remove cover (key 14) from BM
- Unscrew fixing screws (key 15)
- Remove holding pin
- Remove BM
- Unscrew screw (key 1) from connecting part (key 16)
- Remove connecting part (key 16)
- Remove spring (key 17) and valve plug (key 18)
- Unscrew bypass (key 19)

Removing the orifice (not recommended) requires a special extraction tool.

Reassembly

Type BLE (without slam-shut)

- Perform above operations in reverse order (respect tightening torques)
- Replace O-rings at every disassembly
- Lubricate screws before tightening
- Lightly lubricate O-rings (silicone grease)
- Lubricate the stem (key 11) in the rim (key 20) (molybdenum graphite grease)
- Precaution must be taken concerning the passage of the valve plug over the segments

Type BLX (with slam-shut)

As well as above operations

- Lightly lubricate the O-rings (silicone grease) except for the valve plug O-ring
- Precaution must be taken concerning the passage of the valve plug over the segments

- Lightly lubricate the stem (silicone grease)
- Lubricate the release relay mechanism (yoke and bolt (molybdenum graphite grease)
- Lubricate the BMS spring (molybdenum graphite grease)

A special tool is required for reassembling a new orifice.

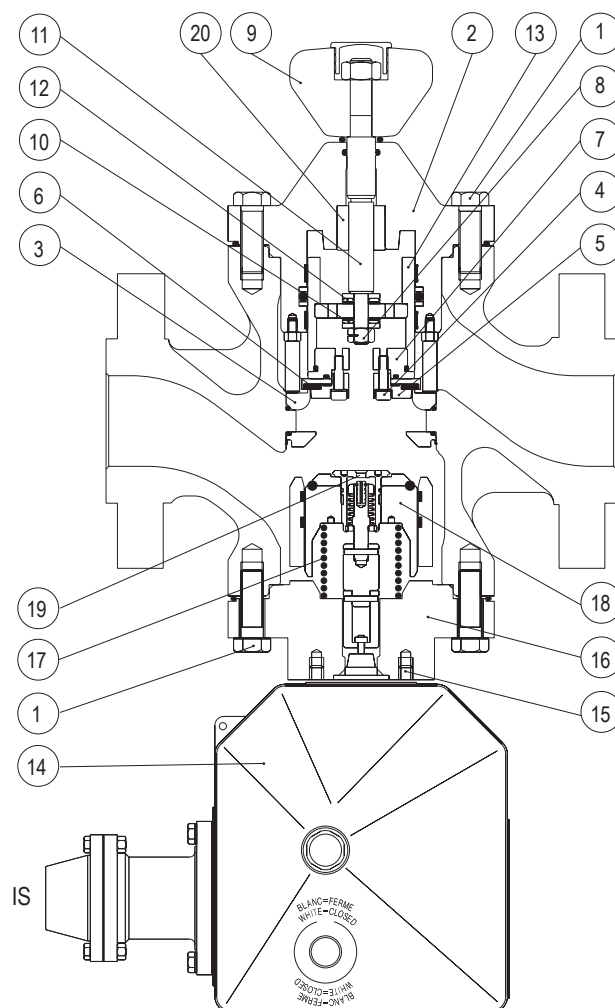

Figure 6. Types BLE and BLX Maintenance Schematic

Types BLE and BLX

SPARE PARTS

Release relay Type OS2: see D103683X012-OS2-IM manual

Table 10. Types BLE and BLX Spare Parts

KEY	DESCRIPTION	QUANTITY	DN 25		DN 50		DN 80		DN 100		
			BLE	BLX	BLE	BLX	BLE	BLX	BLE	BLX	
1	O-ring	1	FA400513X12								
2	O-ring	1	FA400298X12		FA400295X12		FA400297X12		M6020169X12		
3	Guide ring	2	M0274090X12		M0272760X12		M0272810X12		ERAA20327A0		
4	Anti-extrusion washer	2	M0194530X12		M0194690X12		M0192170X12		ERAA20324A0		
5	O-ring	1	FA400524X12		FA400535X12		FA400543X12		ERAA20323A0		
6	O-ring	1	FA400104X12		FA400098X12		FA400107X12		M6020171X22		
7	O-ring	1	FA400105X12		FA400101X12		FA400108X12		-		
8	O-ring	1	FA400106X12		FA400005X12		FA400109X12		ERAA10213A0		
9	Valve plug	1	M0280900X12		M0280910X12		M0280920X12		M02990090X12		
10	Bypass	1		FA180977T12		FA180977T12		FA180977T12		FA180977T12	
11	Valve plug O-ring	1		FA400257T12		FA400263T12		FA400258T12		FA400260T12	
12	Segment	2		FA401950T12		FA401951T12		FA401952T12		FA401953T12	
	Packing gland kit			FA197395X12		FA197395X12		FA197395X12		FA197395X12	
	Spare parts kit*		FA197801X12		FA197802X12		FA197803X12		FA197987X12		

* Including all commissioning spares and O-rings

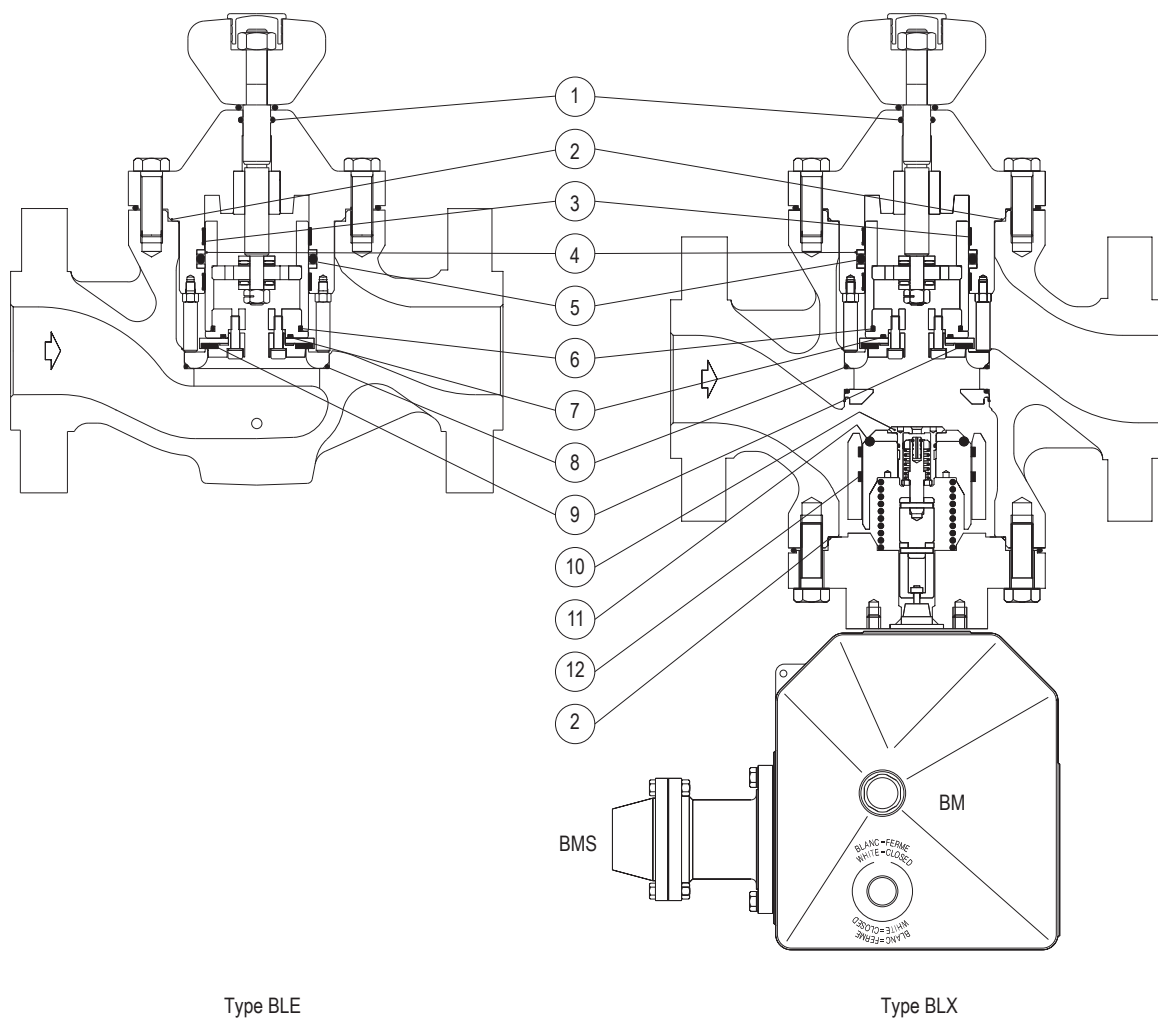

Type BLE

Type BLX

B71

Figure 7. Types BLE and BLX Spare Parts

Types BLE and BLX

 Webadmin.Regulators@emerson.com

 Fisher.com

 Facebook.com/EmersonAutomationSolutions

 LinkedIn.com/company/emerson-automation-solutions

 Twitter.com/emr_automation

Emerson Automation Solutions

Americas

McKinney, Texas 75070 USA
T +1 800 558 5853
+1 972 548 3574

Europe

Bologna 40013, Italy
T +39 051 419 0611

Asia Pacific

Singapore 128461, Singapore
T +65 6770 8337

Middle East and Africa

Dubai, United Arab Emirates
T +971 4 811 8100

*Francel SAS, 3 Avenue Victor Hugo, CS 80125, Chartres 28008, France
SIRET 552 068 637 00057 APE 2651B, N° TVA : FR84552068637, RCS Chartres B 552 068 637,
SAS capital 534 400 Euro*

D103678X012 © 2017, 2018 Emerson Process Management Regulator Technologies, Inc. All rights reserved. 07/18.

The Emerson logo is a trademark and service mark of Emerson Electric Co. All other marks are the property of their prospective owners. Fisher™ is a mark owned by Fisher Controls International LLC, a business of Emerson Automation Solutions.

The contents of this publication are presented for information purposes only, and while effort has been made to ensure their accuracy, they are not to be construed as warranties or guarantees, express or implied, regarding the products or services described herein or their use or applicability. All sales are governed by our terms and conditions, which are available on request. We reserve the right to modify or improve the designs or specifications of our products at any time without notice.

Emerson Process Management Regulator Technologies, Inc does not assume responsibility for the selection, use or maintenance of any product. Responsibility for proper selection, use and maintenance of any Emerson Process Management Regulator Technologies, Inc. product remains solely with the purchaser.

