

# PRESSURE REGULATORS

Type B NV

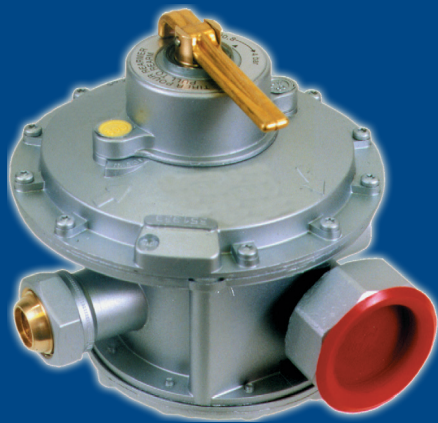

# B NV Regulators

---

## Description

The **Type B NV** residential regulator is a direct-action, spring-loaded regulator, with high performance and reinforced safety features.

Two reduction stages produce a constant outlet pressure which is insensitive to changes in inlet pressure. The regulator is factory preset.

The slam shut cuts the flow in case of excessive flow or when the outlet pressure drops below set point (high gas demand or outlet pipe damaged), or in the case of inlet pressure dropping below the set point (network pressure drops or inlet pipe damaged). Manual reset will activate the regulator after clearing failure.

The regulator is equipped with a factory installed internal relief valve.

A strainer (100 µ) protects the regulator on the inlet side.

## Options

- Different outlet pressure settings (standard or specific)
- Possibility of manual pressure setting
- Factory preset relief valve
- Vent connectable to the exterior
- Underground modules are supplied with corrosion protection
- Possibility of parallel mounting regulators to form a "battery" which give a flow capacity of 2, 3 or 4 times the flow of one regulator with the same high regulating performances

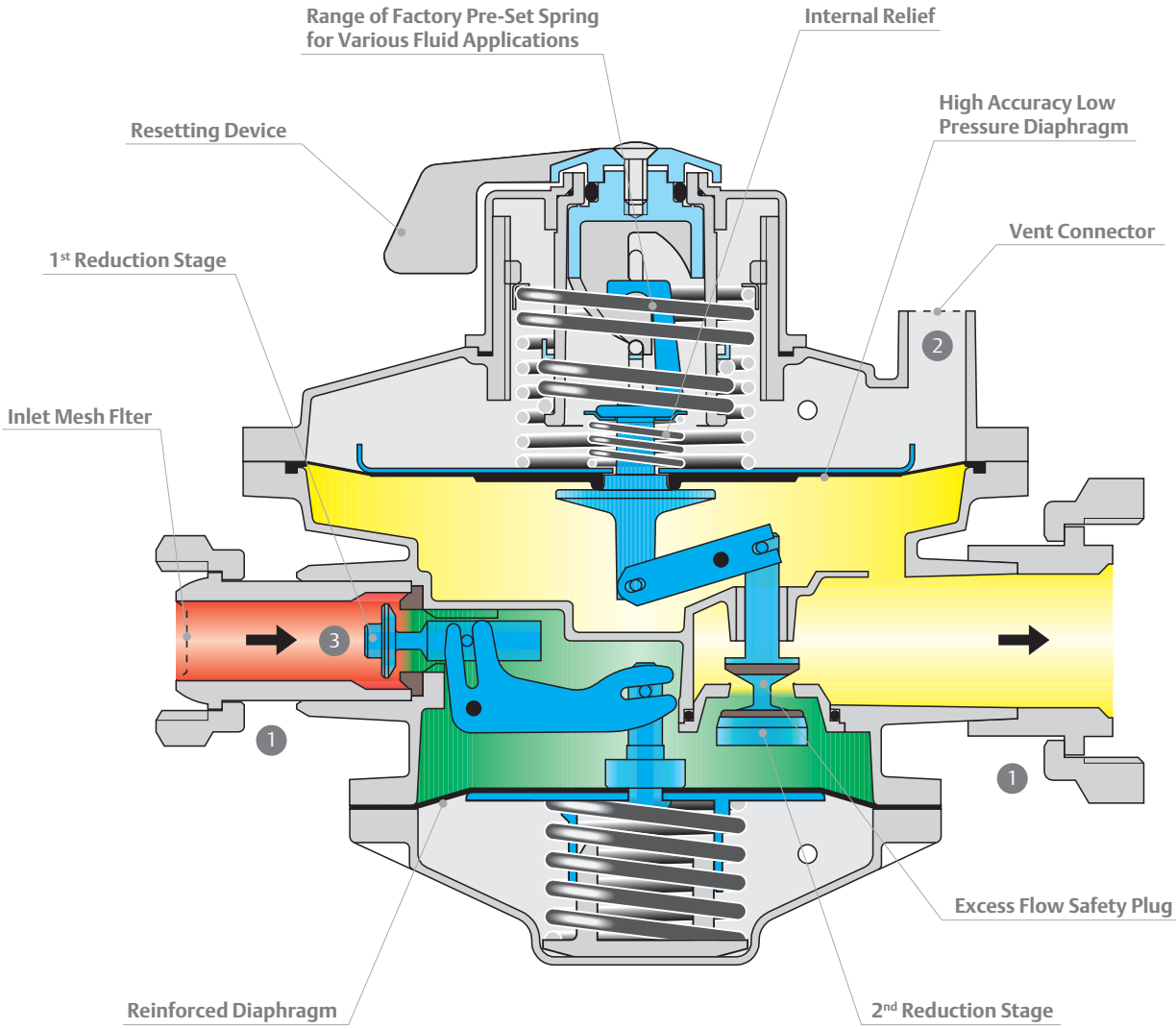

**1 Perfect Connection Control**

- Assembly without the constraints of excessive torquing
- No risk of unscrewing
- Tight shutoff guaranteed

**2 Vent**

- Reduced size
- Protection filter
- Relief valve according to standard NFE29190-2

**3 Perfect Connection Control**

- Security in the case of underpressure, spring to close

# B NV Regulators

## Principle of Operation

### Regulation

Pressure reduction consists of two stages:

- **1<sup>st</sup> reduction stage** takes place between the inlet plug (key 10) and the seat ring (key 11). Tightness is ensured by the plug disc seat (key 10) which closes on the seat ring (key 11). Pressure regulation is controlled by the 1<sup>st</sup> stage diaphragm (key 20) which senses the intermediate pressure on one side and the set pressure of the spring (key 21) on the other. This 1<sup>st</sup> reduction stage supplies the 2nd stage with a constant pressure level.
- **2<sup>nd</sup> reduction stage** takes place between the regulating plug (key 12) and the seat ring (key 13). Pressure reduction is controlled by the 2<sup>nd</sup> stage diaphragm (key 23) which senses the outlet pressure on one side and the set pressure of the spring (key 22) on the other. This spring is factory preset. Finally on modules other than the BCH, the resetting lever also functions as a trip lever by closing the 2<sup>nd</sup> stage regulating plug (key 12).

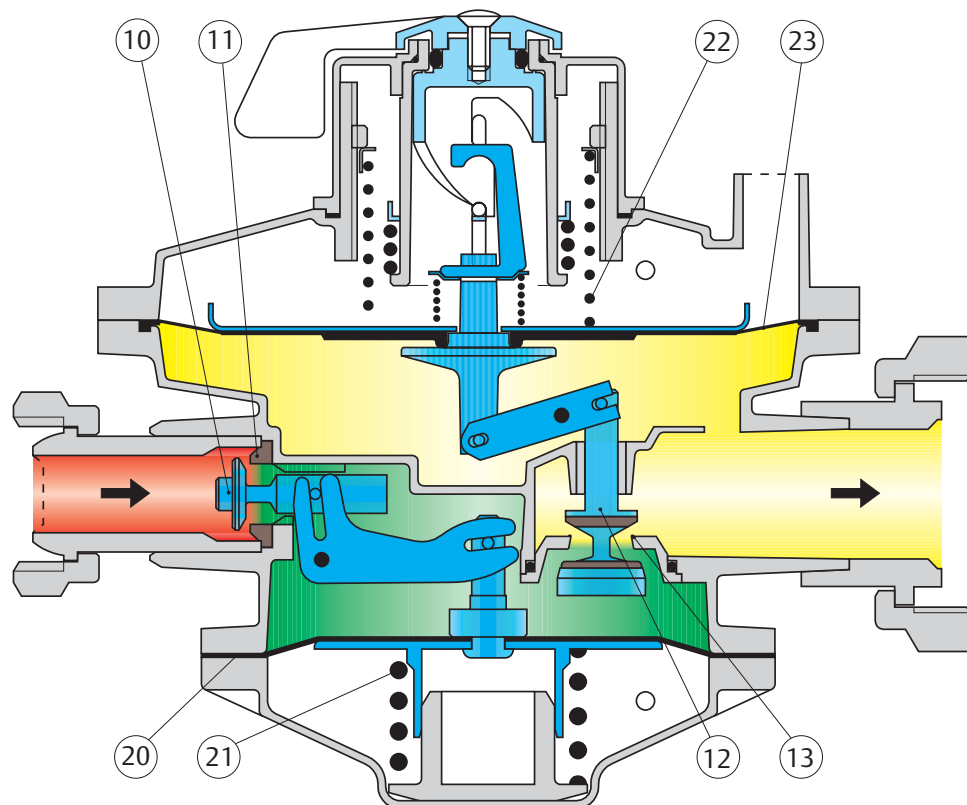

Principle of Operation (continued)

Closing

Tight shutoff is ensured by the plug disc seat (key 12) pushing against the seat ring (key 13).

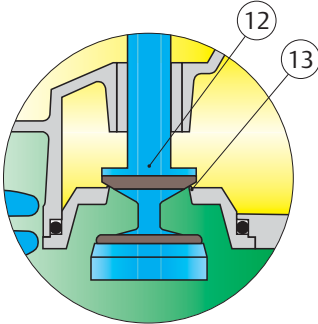

Slam Shut

When the slam-shut plug (key 14) is closed, the 2<sup>nd</sup> stage plug (key 12) is fully opened. The regulator cannot be put back into operation without correcting the cause of failure. The reset lever (key 16) is used to reset the regulator, which opens the slam-shut plug, passes gas to the outlet side, and repositions the 2<sup>nd</sup> stage to a regulating position.

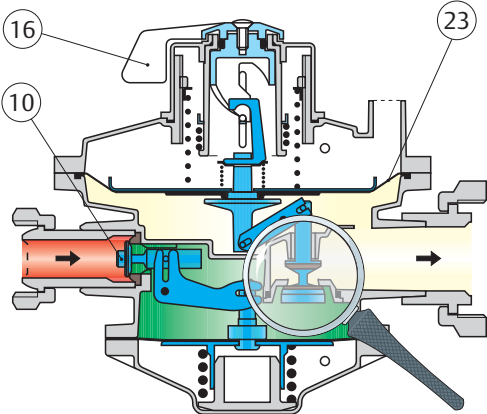

Relief Valve

The relief valve (key 17) opens if the outlet pressure exceeds the set point. This rise in pressure can be due to the following:

With a zero flow condition, a temperature increase in the outlet piping, the outlet pressure will increase. The relief valve will control the outlet pressure which avoids slam shut tripping, flow cut, and maintenance interventions.

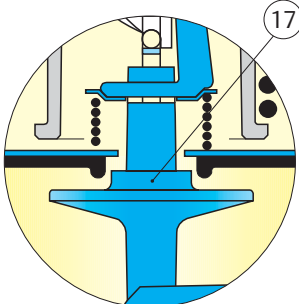

# B NV Regulators

## Principle of Operation (continued)

### Relief Valve (continued)

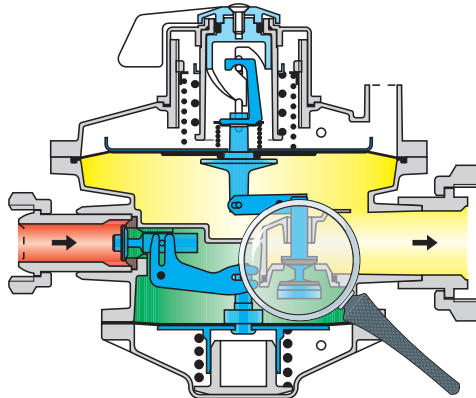

The slam-shut plug (key 14), connected to the 2<sup>nd</sup> stage regulating plug (key 12), cuts off the gas flow in the following situations:

- **Excess flow or Outlet pressure below set point**

The diaphragm (key 23) drops and the regulating plug (key 12) rises, which causes the slam-shut plug (key 14) to close.

- **Inlet pressure below set point**

If the gas network pressure drops below set point, the regulator flow starves and the 1<sup>st</sup> stage plug (key 10) fully opens but is not capable of preserving the intermediate pressure. The 2<sup>nd</sup> stage plug (key 12) fully opens, due to the low intermediate pressure, therefore the slam-shut plug (key 14) will close.

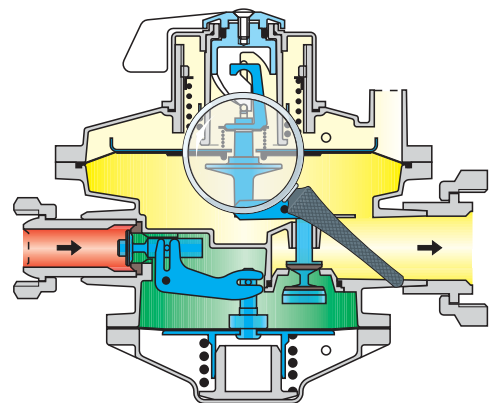
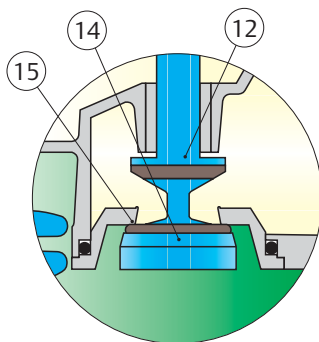

Leakage through the 2<sup>nd</sup> stage plug. The purpose of two reduction stages is to limit leak capacity caused by the intermediate pressure and not by the inlet pressure.

Shock absorption **without tripping the slam shut** in case of flow cut or rapid reset.

## Features

### Technical Features

Inlet pressure Pu : 0.1 to 5 bar depending on type  
 Outlet pressure Pd : 19 to 400 mbar depending on type

### Functional Features

Accuracy class RG : ± 5% B and BCH  
 ± 10% R and H  
 Capacity Q : up to 40 m<sup>3</sup>/h(n) (120 for batteries)  
 Temperature T : -20 to +60 °C

### End Connection Styles

Inlet : Sphero-conical or flat joint connection (without joint)  
 Outlet : Flat meter joint or 1 1/4" JPG nut (with joint)  
 Vent : Diameter 10

Regulator		Inlet		Outlet	
		Connector	Torque	Connector	Torque
B25N	R25	Cal 15 JSC	40 N.m	Cal 32 JPC	50 N.m
BCH30N	H30			Cal 25 JPG	60 N.m

JSC: Sphero-conical joint    JPC: Flat meter joint    JPG: Flat gas joint

## Materials

Body Zinc/Aluminum alloy  
 Castings Zinc/Aluminum alloy  
 Inlet nut Brass  
 Outlet nut Brass  
 Diaphragms Nitrile  
 Plugs/Seats Brass/Nitrile

## Specified Items

		21	27	37	300	Other
B25/R25	Item disc	Red	Black	White	Yellow	Grey
BCH30/H30		-	-	-	Yellow	Grey



ID disc example

# B NV Regulators

## Features (continued)

### Inlet and Outlet Pressures

Type	Regulator	Pu (bar)	Pd (mbar)
Standard	B25/B25E	0.5 to 5	19 to 46
	BCH30/BCH30E	0.8 to 5	300
R	R25	0.3 to 4	19 to 46
H	H30	0.8 to 5	46 to 400

### Outlet Pressures Ranges

Standard Pressure Range					
Regulator	B25	B25E	BCH30	R25	H
Standard Pu	21, 27 or 37	21 or 27	300	21, 27 or 37	(*)

\* See page 11 for regulator type

Relief Valve Activation Pressure Ranges					
Pu		21	27	37	300
Functioning range	Minimum	35	37.5	47	350
	Maximum	50	50	60	400

### Flow Ranges

Nominal Flow Capacity (Natural Gas m <sup>3</sup> /h(n)*)				
Regulator	B25	BCH30	R25	H
Capacity	25	30	25	10 to 40

\* Propane: multiply the value by 1.2 to obtain flow capacity in kg/h

Minimum Shutoff Rate in Case of Excess Flow				
Pd	B25	BCH30	R25	H
5	30	36		30*
4				
0.8				
0.5	28		25	
0.4				
0.3				
0.2				
0.1				
0.1	13		13	

\* Depending on Pu and Pd pair

### Maximum shutoff rate in case of excess flow

150% of nominal flow in the Pu nominal range



Features (continued)

Flow Curves

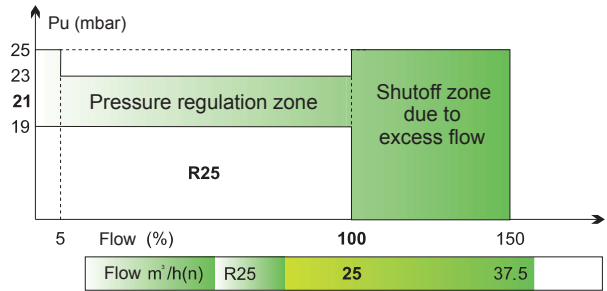
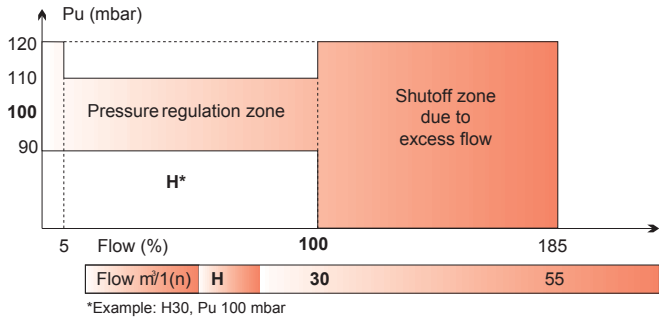
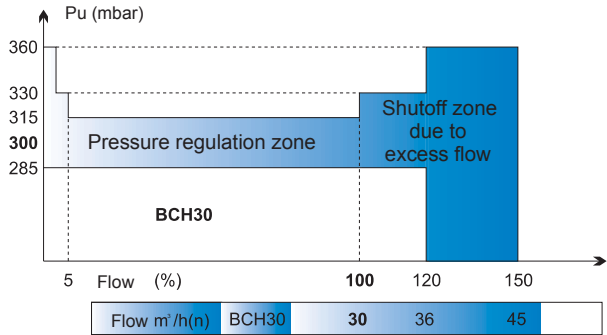
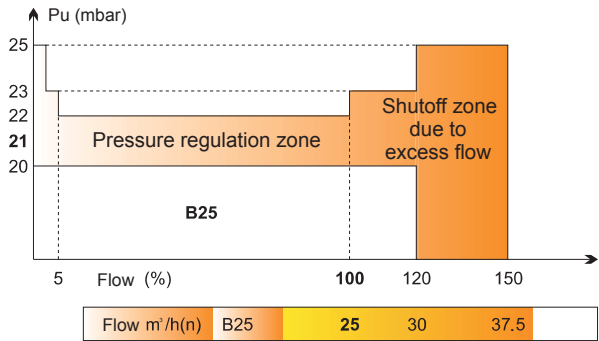

# B NV Regulators

## Installation

The regulator can be installed directly onto the meter or by adapted connectors. It can be mounted in any position. Install using the following schema.

The regulator does not require an external sensing lines as pressure sensing is internal.

Use the nuts as recommended (inlet and outlet) on page 11. For underground installations, use modules with reference no. E.

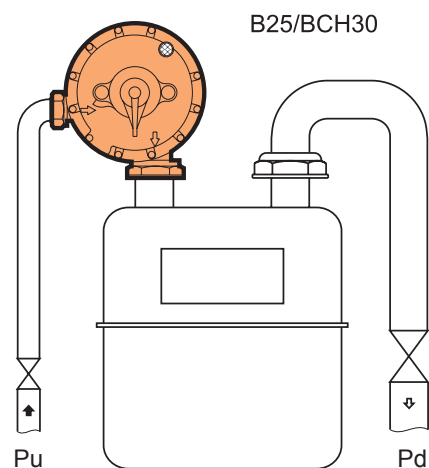

## Dimensions (mm) and Weights (kg)

### Dimensions

#### Types B25, BCH30, H, R25

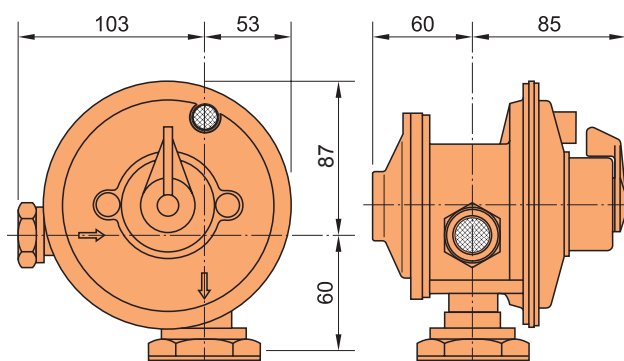

### Weight

All B NV: 2 kg

## Regulator Selection Tables and Options

### Regulators

Standard Regulators Information		
Type	Regulator	Pu (bar)
B	B25	0.5
BE	B25E	
R	R25	0.3
BCH	BCH30	0.8
BCHE	BCH30E	
H	H30	

"Battery" Regulators Information		
Type	Regulator	Resetting Options
B	B25	With or without
BCH	BCH30	

### Options

Outlet Options	
Regulator	Connection Styles
R25	Nipple Cal 32 JPC Soldering steel 42.4
	Nipple Cal 32 JPC Brazing copper 35x1
	Flat ring Cal 32 JPC (by 10)
BCH30, H30	Nipple Cal 25 JPG Soldering steel 33.7
	Nipple Cal 32 JPG Brazing copper 28x1
	Flat ring Cal 32 JPG (by 10)

Inlet Options	
Regulator	Connection Styles
All modules	Nipple Cal 15 JSC Soldering steel 21.3
	Nipple Cal 15 JSC Brazing copper 12x1
	Nipple Cal 15 JSC Brazing copper 18x1

### Important ordering information for batteries

- Specify set point
- Warning, for battery use only, all «battery» regulators must be replaced at the same time
- Inlet nut: JSC Cal 15
- Outlet nut: JPC Cal 32  
(BCH30 as well, but it is strongly forbidden to use this regulator on its own)
- In battery installations, the B25 are joined by an equilibrium tube
- Only one reset regulator is necessary on a battery installation

 [Webadmin.Regulators@emerson.com](mailto:Webadmin.Regulators@emerson.com)

 Fisher.com

 [Facebook.com/EmersonAutomationSolutions](https://www.facebook.com/EmersonAutomationSolutions)

 [LinkedIn.com/company/emerson-automation-solutions](https://www.linkedin.com/company/emerson-automation-solutions)

 [Twitter.com/emr\\_automation](https://twitter.com/emr_automation)

## Emerson Automation Solutions

### Americas

McKinney, Texas 75070 USA

T +1 800 558 5853  
+1 972 548 3574

### Europe

Bologna 40013, Italy  
T +39 051 419 0611

### Asia Pacific

Singapore 128461, Singapore

T +65 6770 8337

### Middle East and Africa

Dubai, United Arab Emirates  
T +971 4 811 8100

**O.M.T. Officina Meccanica Tartarini S.R.L.**, Via P. Fabbri 1, I-40013 Castel Maggiore (Bologna), Italy  
R.E.A 184221 BO Cod. Fisc. 00623720372 Part. IVA 00519501209 N° IVA CEE IT 00519501209,  
Cap. Soc. 1.548 000 Euro i.v. R.I. 00623720372 - M BO 020330

**Francel SAS**, 3 Avenue Victor Hugo, CS 80125, Chartres 28008, France  
SIRET 552 068 637 00057 APE 2651B, N° TVA : FR84552068637, RCS Chartres B 552 068 637,  
SAS capital 534 400 Euro

D104252X012 © 2017 Emerson Process Management Regulator Technologies, Inc. All rights reserved. 10/17.

The Emerson logo is a trademark and service mark of Emerson Electric Co. All other marks are the property of their prospective owners.

Fisher™ is a mark owned by Fisher Controls International LLC, a business of Emerson Process Management.

The contents of this publication are presented for information purposes only, and while effort has been made to ensure their accuracy, they are not to be construed as warranties or guarantees, express or implied, regarding the products or services described herein or their use or applicability. All sales are governed by our terms and conditions, which are available on request. We reserve the right to modify or improve the designs or specifications of our products at any time without notice.

Emerson Process Management Regulator Technologies, Inc does not assume responsibility for the selection, use or maintenance of any product. Responsibility for proper selection, use and maintenance of any Emerson Process Management Regulator Technologies, Inc. product remains solely with the purchaser.

